

ACCESSORY KIT INSTALLATION MANUAL

THERMAL EXPANSION VALVE KITS R-22 – (S1-1TVM2**, 1TVM7**) & R-410A – (S1-1TVM4**, S1-1TVM9**, S1-1TVMBA2, S1-1TVMBB2, S1-1TVMBC2, S1-1TVMBD2)

FOR USE WITH MODELS: COILS - FC, MC, PC, UC, HD, HC, G4FA, G4FD & AIR HANDLERS - AH, AV, F*FP, RFCX*E, & RTCX*P

GENERAL INFORMATION

This thermal expansion valve (with internal check valve) is to be used with flex coils for models listed above. This kit is required to provide overall rated system performance improvement. The kit can be applied to the listed indoor (ID) coils and air handlers, both for heat pump and cooling applications.

The kit consists of a bolt-on thermal expansion valve, 2.5 feet of thermal insulation, bulb straps or bulb clamp and this instruction.

When a TXV kit is installed, a hard start kit may be required. Consult your outdoor (OD) Tabular Data Sheet

Refer to Tabular Data Sheet for specific model TXV/match-up.

- 1TVM2, 1TVM7 series TXV kits are R-22 AC and HP.
- 1TVM4, 1TVM9 series TXV kits are for R-410A AC and HP.

INSTALLATION

To install the thermal expansion valve, use the following steps. The coil may have to be pulled out of the casing for installation access.

WARNING

The ID coil is under 30 psig of pressure.

1. Relieve the holding charge by pulling off the rubber cap plug on the suction manifold line of the coil
2. After holding charge is completely discharged, loosen and remove the schraeder cap seal.
3. Loosen and remove distributor cap seal.
4. Install the thermal expansion valve to the orifice distributor assembly with supplied fittings. Orient the TXV as shown in Figure 1. Hand tighten and turn an additional 1/4 turn to seal. Do not overtighten fittings.

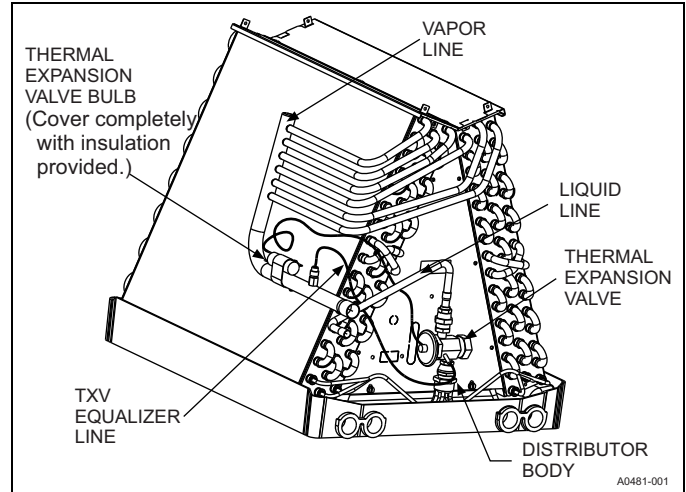

FIGURE 1: Kit Installation in System

5. Install the liquid line to the top of the thermal expansion valve with fitting supplied with the liquid line. Hand modify the liquid line to align with casing opening. Hand tighten the liquid line and an additional 1/4 turn to seal.
6. Install the TXV equalizer line into the vapor line as follows:
 - a. Hand tighten the 1/4" SAE nut to the schraeder fitting and an additional 1/3 turn to seal.
7. Install the TXV bulb to the vapor line near the equalizer line, using the bulb clamp(s) furnished with the TXV assembly. Ensure the bulb is making maximum contact. See Figure 2 for proper bulb location. See Figure 3 for clamp assembly on 1TVM valve.
 - a. Bulb should be installed on a horizontal run of the vapor line if possible. The bulb should be installed at a 10 o'clock or 2 o'clock position.
 - b. If bulb installation is made on a vertical run, the bulb should be located at least 16 inches from any bend, and on the tubing sides opposite the plane of the bend. The bulb should be positioned with the bulb tail at the top, so that the bulb acts as a reservoir.
 - c. Bulb should be insulated using thermal insulation provided to protect it from the effect of the surrounding ambient temperature. Cover completely to insulate from air-stream.
8. Slide the coil in the cabinet and install the tubing connect plate. Soak the heat shield in water and slide it in place using the suction and liquid line holes provided.
9. Align the suction and liquid line sets to the suction and liquid tubing and wrap the liquid and suction tubing with wet rag before brazing.

CAUTION

Dry nitrogen should always be supplied through the tubing while it is being brazed, because the temperature is high enough to cause oxidation of the copper unless an inert atmosphere is provided. The flow of dry nitrogen should continue until the joint has cooled. Always use a pressure regulator and safety valve to insure that only low pressure dry nitrogen is introduced into the tubing. Only a small flow is necessary to displace air and prevent oxidation.

All connections to be brazed are copper-to-copper and should be brazed with a phosphorous-copper alloy material such as Silfos-5 or equivalent. DO NOT use soft solder.

Nitrogen can be introduced through the Schraeder access (located at the OD unit connection of the refrigerant line). The Schraeder core can be removed before connecting the source of nitrogen, but should be reinstalled prior to the evacuation and charging of the refrigerant lines and ID coil.

10. Braze the line set to the units
11. Leak check refrigerant lines and ID coil connections. If leak free, remove leak check charge, reinstall any Schraeder cores that were removed from the OD unit and evacuate refrigerant lines and ID coil. Evacuate through the Schraeder access valves of the liquid and vapor service valves on OD unit.

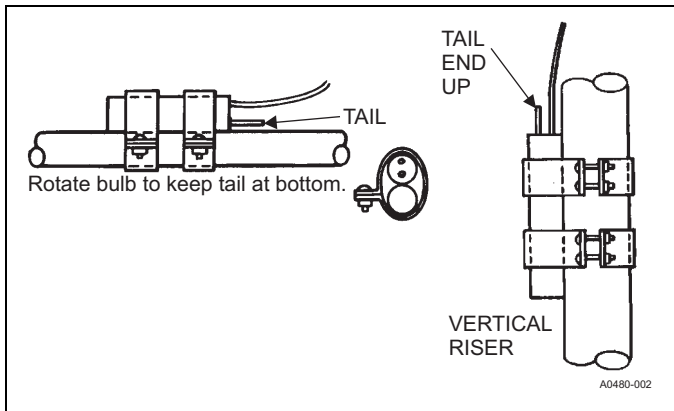

FIGURE 2: Correct Bulb Locations

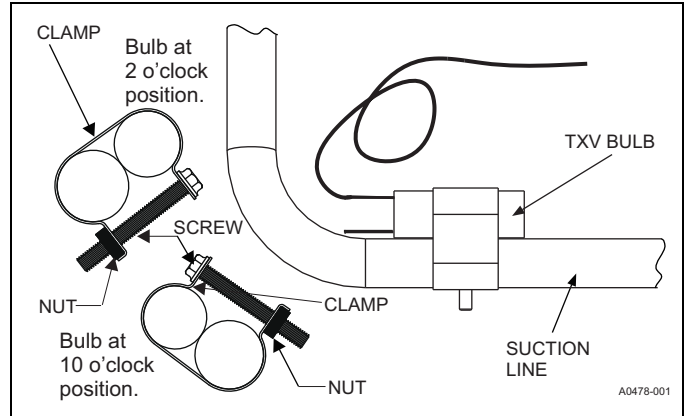

FIGURE 3: Clamp Attachment for 1TVM (Option 1)

12. After the interconnecting refrigerant lines, TXV assembly and ID coil have been evacuated, the liquid and vapor line valves at the OD unit can be opened to release the refrigerant charge into the complete system. The proper procedure for opening these valves is covered in the OD unit installation instructions.
13. The OD unit factory refrigerant charge includes the charge for 15 feet of interconnecting vapor and liquid lines. If interconnecting lines are longer than 15 feet, additional charge must be added for the length. You may refer to "Refrigerant Piping Guide" for line sets over 25 ft. The OD unit installation instructions list the charge required per foot of liquid/vapor lines. Also, some ID coil matches may require additional charge. This charge is also listed in the OD unit installation instruction. The additional charge should be introduced into the system by means of a calibrated charging cylinder or other means of accurately weighing the refrigerant.

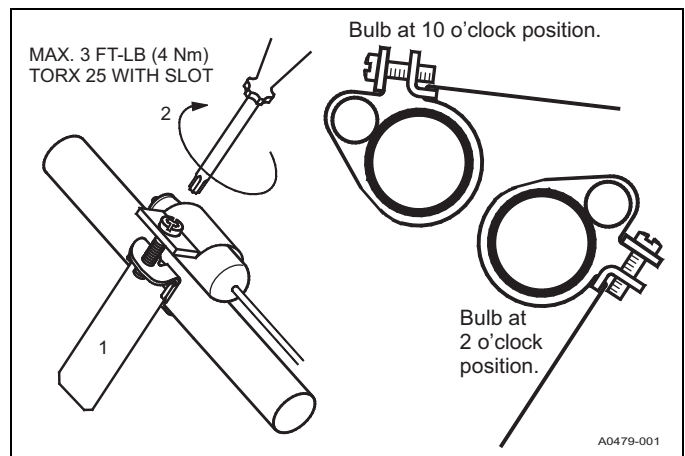

FIGURE 4: Clamp Attachment for 1TVM (Option 2)