

PLA-A18EA7 & PUY-A18NKA7(-BS)
18,000 BTU/H 3' X 3' CEILING CASSETTE
18,000 BTU/H COOLING ONLY OUTDOOR



Job Name:

System Reference:

Date:



Indoor Unit.....PLA-A18EA7

Outdoor Unit

Standard Model.....PUY-A18NKA7

Seacoast Model.....PUY-A18NKA7-BS

INDOOR UNIT FEATURES

- Space-efficient ductless installation
- Equipped with 3D i-see Sensor® for enhanced comfort and energy efficiency
- Airflow settings for high and low ceiling applications
- Individual vane settings for direct/indirect airflow control or variable airflow patterns
- Knockouts for outside-air intake and branch-duct run
- Filter indicator signal
- Easy-to-clean, washable filter (optional high-efficiency filter available - requires multi-function casement)
- Built-in condensate lift mechanism
- Ideal for retail shops, classrooms, office spaces, conference centers, building lobbies, and more
- Multiple control options available:
 - kumo cloud® smart device app for remote access
 - Third-party interface options
 - Wired or wireless controllers

OUTDOOR UNIT FEATURES

- Variable speed INVERTER-driven compressor
- Power receiver pre-charged with refrigerant volume for piping length up to 70 ft
- Low ambient cooling down to -40°F providing 100% capacity (only for PUY models with wind baffles installed)
- 24-hour continuous operation (cooling mode)
- High pressure protection
- Fast restart due to bypass valve make it ideal for equipment cooling applications, such as data centers
- Superior energy and operational efficiency

SPECIFICATIONS: PLA-A18EA7 & PUY-A18NKA7(-BS)

Cooling at 95°F ¹	Maximum Capacity	BTU/H	18,000
	Rated Capacity	BTU/H	18,000
	Minimum Capacity	BTU/H	8,000
	Maximum Power Input	W	1,250
	Rated Power Input	W	1,250
	Moisture Removal	Pints/h	2.4
	Sensible Heat Factor		0.85
Efficiency	Power Factor	%	95.3/95.3
	SEER		24.6
	EER ¹		14.4
Electrical	ENERGY STAR® Certified		Yes
	Voltage, Phase, Frequency		208/230, 1, 60
	Guaranteed Voltage Range	V AC	198 - 253
	Voltage: Indoor - Outdoor, S1-S2	V AC	208/230
	Voltage: Indoor - Outdoor, S2-S3	V DC	24
	Short-circuit Current Rating [SCCR]	kA	5
	Recommended Fuse/Breaker Size (Outdoor)	A	15
Indoor Unit	Recommended Wire Size [Indoor - Outdoor]	AWG	14
	MCA	A	1.0
	Fan Motor Full Load Amperage	A	0.36
	Fan Motor Output	W	50
	Airflow Rate at Cooling, Dry	CFM	420–460–570–600
	Airflow Rate at Cooling, Wet	CFM	380–420–530–560
	Airflow Rate at Heating, Dry	CFM	420–460–570–600
	Sound Pressure Level [Cooling]	dB[A]	28–29–31–32
	Sound Pressure Level [Heating]	dB[A]	28–29–31–32
	Drain Pipe Size	In. [mm]	1-1/4 [32]
	Condensate Lift Mechanism, Maximum Distance	In. [mm]	33-7/16 [849]
	Coating on Heat Exchanger		—
	External Finish Color		White Munsell 6.4Y 8.9/0.4
	Unit Dimensions	W x D x H: In. [mm]	33-1/16 // 37-13/32 x 33-1/16 // 37-13/32 x 10-5/32 // 1-9/16 [840 // 950 x 840 // 950 x 258 // 40]
	Package Dimensions	W x D x H: In. [mm]	35-9/16 // 39-6/16 x 34-5/16 // 38-3/16 x 15 // 4-12/16 [903 // 1000 x 871 // 970 x 381 // 121]
Unit Weight	Lbs. [kg]	46 // 11 [21 // 5]	
Package Weight	Lbs. [kg]	68 [31]	
Indoor Unit Operating Temperature Range	Cooling Intake Air Temp [Maximum / Minimum]*	°F	95 DB, 71 WB / 67 DB, 57 WB
	Heating Intake Air Temp [Maximum / Minimum]	°F	80 DB / 70 DB
Outdoor Unit	MCA	A	11.0
	MOCP	A	28
	Fan Motor Full Load Amperage	A	0.5
	Fan Motor Output	W	46
	Airflow Rate	CFM	1590
	Refrigerant Control		LEV
	Defrost Method		Reverse Cycle
	Coating on Heat Exchanger		Blue Fin Coating (BS Model only)
	Sound Pressure Level, Cooling ¹	dB(A)	44
	Compressor Type		INVERTER-driven twin rotary
	Compressor Model		SNB130FNCM2
	Compressor Rated Load Amps	A	7.0
	Compressor Locked Rotor Amps	A	12.0
	Compressor Oil Type // Charge	oz.	FV50S // 16
	External Finish Color		Ivory Munsell 3Y 7.8/1.1
	Base Pan Heater		N/A
	Unit Dimensions	W x D x H: In. [mm]	31-13/16 (+7/16) x 11-3/16 x 24-13/16 [809 (+62) x 300 x 630]
	Package Dimensions	W x D x H: In. [mm]	37-1/16 x 16-3/16 x 27-7/16 [941 x 411 x 670]
Unit Weight	Lbs. [kg]	99 [44]	
Package Weight	Lbs. [kg]	110 [50]	

NOTES:

AHRI Rated Conditions

(Rated data is determined at a fixed compressor speed)

¹ Cooling (Indoor // Outdoor)	°F	80 DB, 67 WB // 95 DB, 75 WB
² Heating at 47°F (Indoor // Outdoor)	°F	70 DB, 60 WB // 47 DB, 43 WB
³ Heating at 17°F (Indoor // Outdoor)	°F	70 DB, 60 WB // 17 DB, 15 WB

Conditions

⁴ Heating at 5°F (Indoor // Outdoor)	°F	70 DB, 60 WB // 5 DB, 4 WB
⁵ Heating at -4°F (Indoor // Outdoor)	°F	70 DB, 60 WB // -4 DB, -5 WB
⁶ Heating at -5°F (Indoor // Outdoor)	°F	70 DB, 60 WB // -5 DB, -6 WB
⁷ Heating at -13°F (Indoor // Outdoor)	°F	70 DB, 60 WB // -13 DB, -14 WB

*Outdoor Unit Operating Temperature Range (Cooling Air Temp (Maximum / Minimum)):

- Applications should be restricted to comfort cooling only; equipment cooling applications are not recommended for low ambient temperature conditions.
 - » Wind baffles required to operate below 23°F DB in cooling mode.
 - » Cooling-only system with wind baffle: -40°F - 115°F.
 - » Heat pump system with wind baffle: 0°F - 115°F.
 - » Refer to wind baffle documentation for further information.

**Outdoor Unit Operating Temperature Range (Cooling Thermal Lock-out / Re-start Temperatures; Heating Thermal Lock-out / Re-start Temperatures):

- System cuts out in heating mode to avoid thermistor error and automatically restarts at these temperatures.

SEACOAST PROTECTION (-BS MODELS)

- External Outer Panel: Phosphate coating + Acrylic-Enamel coating
- Fan Motor Support: Epoxy resin coating (at edge face)
- Separator Assembly Valve Bed: Epoxy resin coating (at edge face)
- Blue Fin treatment is an anti-corrosion treatment that is applied to the condenser coil to protect it against airborne contaminants.

SPECIFICATIONS: PLA-A18EA7 & PUY-A18NKA7(-BS)

Outdoor Unit Operating Temperature Range	Cooling Air Temp [Maximum / Minimum]*	°F	115 DB / -40 DB
Refrigerant	Type		R410A
	Charge	Lbs, oz	4, 14
	Chargeless Piping Length	Ft. [m]	70.0 [20.0]
	Additional Refrigerant Charge Per Additional Piping Length	oz./Ft. [g/m]	0.1 [7.5]
Piping	Gas Pipe Size O.D. [Flared]	In.[mm]	1/2 [12.7]
	Liquid Pipe Size O.D. [Flared]	In.[mm]	1/4 [6.35]
	Maximum Piping Length	Ft. [m]	165 [50]
	Maximum Height Difference	Ft. [m]	100 [30]
	Maximum Number of Bends		15

NOTES:

AHRI Rated Conditions (Rated data is determined at a fixed compressor speed)	¹ Cooling (Indoor // Outdoor) ² Heating at 47°F (Indoor // Outdoor) ³ Heating at 17°F (Indoor // Outdoor)	°F °F °F	80 DB, 67 WB // 95 DB, 75 WB 70 DB, 60 WB // 47 DB, 43 WB 70 DB, 60 WB // 17 DB, 15 WB
Conditions	⁴ Heating at 5°F (Indoor // Outdoor) ⁵ Heating at -4°F (Indoor // Outdoor) ⁶ Heating at -5°F (Indoor // Outdoor) ⁷ Heating at -13°F (Indoor // Outdoor)	°F °F °F °F	70 DB, 60 WB // 5 DB, 4 WB 70 DB, 60 WB // -4 DB, -5 WB 70 DB, 60 WB // -5 DB, -6 WB 70 DB, 60 WB // -13 DB, -14 WB

*Outdoor Unit Operating Temperature Range (Cooling Air Temp (Maximum / Minimum)):

- Applications should be restricted to comfort cooling only; equipment cooling applications are not recommended for low ambient temperature conditions.
 - » Wind baffles required to operate below 23°F DB in cooling mode.
 - » Cooling-only system with wind baffle: -40°F - 115°F.
 - » Heat pump system with wind baffle: 0°F - 115°F.
 - » Refer to wind baffle documentation for further information.

**Outdoor Unit Operating Temperature Range (Cooling Thermal Lock-out / Re-start Temperatures; Heating Thermal Lock-out / Re-start Temperatures):

- System cuts out in heating mode to avoid thermistor error and automatically restarts at these temperatures.

SEACOAST PROTECTION (-BS MODELS)

- External Outer Panel: Phosphate coating + Acrylic-Enamel coating
- Fan Motor Support: Epoxy resin coating (at edge face)
- Separator Assembly Valve Bed: Epoxy resin coating (at edge face)
- Blue Fin treatment is an anti-corrosion treatment that is applied to the condenser coil to protect it against airborne contaminants.

INDOOR UNIT ACCESSORIES: PLA-A18EA7

Control Interface	3-Pin Connector	<input type="checkbox"/> PAC-715AD
	CN24 Relay Kit	<input type="checkbox"/> CN24RELAY-KIT-CM3
	IT Extender	<input type="checkbox"/> PAC-WHS01IE-E
	kumo station® for kumo cloud®	<input type="checkbox"/> PAC-WHS01HC-E
	Lockdown bracket for remote controller	<input type="checkbox"/> RCMKP1CB
	Remote Operation Adapter†	<input type="checkbox"/> PAC-SF40RM-E
	Thermostat Interface	<input type="checkbox"/> PAC-US444CN-1
	USNAP Adapter	<input type="checkbox"/> PAC-WHS01UP-E
Remote Sensor	Wireless Interface for kumo cloud®	<input type="checkbox"/> PAC-USWHS002-WF-2
	Flush Mount Temperature Sensor	<input type="checkbox"/> PAC-USSEN001-FM-1
	Remote Temperature Sensor surface mount	<input type="checkbox"/> PAC-SE41TS-E
Wired Remote Controller	Wireless temperature and humidity sensor for kumo cloud®	<input type="checkbox"/> PAC-USWHS003-TH-1
	Deluxe Wired MA Remote Controller†	<input type="checkbox"/> PAR-40MAAU
	Simple MA Remote Controller†	<input type="checkbox"/> PAC-YT53CRAU-J
Wireless Remote Controller	Touch MA Controller†	<input type="checkbox"/> PAR-CT01MAU-SB
	kumo touch™ RedLINK™ Wireless Controller	<input type="checkbox"/> MHK2
	Wireless Remote Controller	<input type="checkbox"/> PAR-SL100A-E
Casement	Wireless Signal Receiver Panel	<input type="checkbox"/> PAR-SR4LU-E
	Multi-function Casement	<input type="checkbox"/> PAC-SJ41TM-E
Condensate	Blue Diamond (Advanced) Mini Condensate Pump w/ Reservoir & Sensor (208/230V) [recommended]	<input type="checkbox"/> X87-721
	Blue Diamond (MicroBlue) Mini Condensate Pump (110/208/230V) up to 18,000 BTU/H	<input type="checkbox"/> X85-003
	Blue Diamond Sensor Extension Cable — 15 Ft.	<input type="checkbox"/> C13-103
Disconnect Switch	(30A/600V/UL) [fits 2" X 4" utility box] - Black	<input type="checkbox"/> TAZ-MS303
	(30A/600V/UL) [fits 2" X 4" utility box] - White	<input type="checkbox"/> TAZ-MS303W
Filter	High Efficiency Filter Element	<input type="checkbox"/> PAC-SH59KF-E
i-see Sensor® Panel	Grille with 3D i-see Sensor® (required)	<input checked="" type="checkbox"/> PLP-41EAEU
Lineset	100' x 1/4" x 100' / 1/2" Lineset (Twin-Tube Insulation)	<input type="checkbox"/> MLS141212T-100
	15' x 1/4" x 15' / 1/2" Lineset (Twin-Tube Insulation)	<input type="checkbox"/> MLS141212T-15
	30' x 1/4" x 30' / 1/2" Lineset (Twin-Tube Insulation)	<input type="checkbox"/> MLS141212T-30
	50' x 1/4" x 50' / 1/2" Lineset (Twin-Tube Insulation)	<input type="checkbox"/> MLS141212T-50
	65' x 1/4" x 65' / 1/2" Lineset (Twin-Tube Insulation)	<input type="checkbox"/> MLS141212T-65
Shutter Plate	Drain Pan	<input type="checkbox"/> PAC-SJ37SP-E
Space Panel	Architectural Surround for Ceiling Recessed Units	<input type="checkbox"/> PLFY-ITP1
	Space Panel	<input type="checkbox"/> PAC-SJ38AS-E

NOTES:

- †PAC-SF40RM-E (Unable to use with wireless remote controller)
 • Ceiling Cassette, Ceiling Suspended, Horizontal-ducted and Multi-position Air Handler

OUTDOOR UNIT ACCESSORIES: PUY-A18NKA7(-BS)

Air Outlet Guide	Air Outlet Guide	<input type="checkbox"/> PAC-SJ07SG-E
Centralized Drain Pan	Centralized Drain Pan	<input type="checkbox"/> PAC-SG63DP-E
Control/Service Tool	Control/Service Tool	<input type="checkbox"/> PAC-SK52ST
	M- & P-Series Maintenance Tool Cable Set	<input type="checkbox"/> M21EC0397
	USB/UART Conversion Cable (Required for all laptop connection)	<input type="checkbox"/> M21EC1397
Drain Socket	Drain Socket	<input type="checkbox"/> PAC-SJ08DS-E
Hail Guards	Hail Guard	<input type="checkbox"/> HG-A5
M-NET Converter	M-NET Converter	<input type="checkbox"/> PAC-SJ96MA-E
Mini-Split Wire	14 Gauge, 4 wire MiniSplit Cable—250 ft. roll	<input type="checkbox"/> S144-250
	14 Gauge, 4 wire MiniSplit Cable—50 ft. roll	<input type="checkbox"/> S144-50
	16 Gauge, 4 wire MiniSplit Cable—250 ft. roll	<input type="checkbox"/> S164-250
	16 Gauge, 4 wire MiniSplit Cable—50 ft. roll	<input type="checkbox"/> S164-50
Mounting Pad	Condensing Unit Mounting Pad: 16" x 36" x 3"	<input type="checkbox"/> ULTRILITE1
Stand	18" Single Fan Stand	<input type="checkbox"/> QSMS1801M
	24" Single Fan Stand	<input type="checkbox"/> QSMS2401M
	Condenser Wall Bracket	<input type="checkbox"/> QSWB2000M-1
	Condenser Wall Bracket -Stainless Steel Finish	<input type="checkbox"/> QSWBSS
	Outdoor Unit Stand — 12" High	<input type="checkbox"/> QSMS1201M
Wind Baffle	Front Wind Baffle	<input type="checkbox"/> WB-PA4
	Rear Wind Baffle	<input type="checkbox"/> WB-RE4
	Side Advanced Wind Baffle	<input type="checkbox"/> WB-SD4

INDOOR UNIT DIMENSIONS: PLA-A18EA7

Unit: inch (mm)

1. NOTE: CHOOSE THE GRILLE AMONG THE DESIGNATED GRILLES.
2. REINFORCE THE SUSPENSION BOLT FOR EARTHQUAKE-RESISTANCE AS NEEDED.
3. PROCEED AT THE LOCAL SITE.
4. FOR DRAIN PIPE, USE W-2410, H-1411, (2) PVC TUBE.
5. DRAIN IS MADE BY CONNECTION FROM THE CEILING.
6. ELECTRICAL BOX MAY BE REMOVED FOR THE SERVICE PURPOSE.
7. REQUIRE "E" OR MORE SPACE BETWEEN RANSOM AND CEILING FOR THE INSTALLATION.
8. WHEN INSTALLING THE BRANCH DUCTS, BE SURE TO INSULATE ADEQUATELY.
9. AS FOR NECESSARY INSTALLATION SERVICE SPACE, PLEASE REFER TO THE MULTIFUNCTIONAL CASEMENT REFER TO SPECIAL DRAWING.

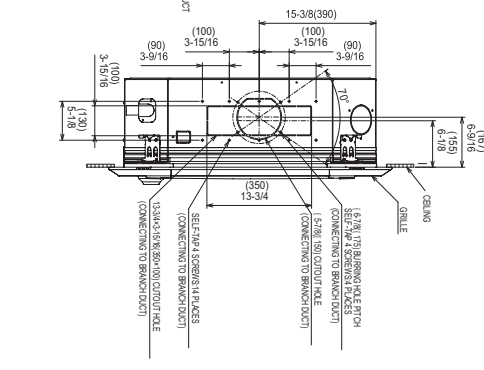
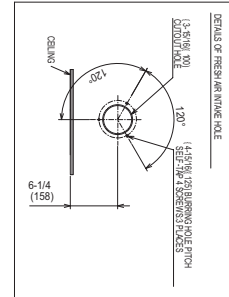
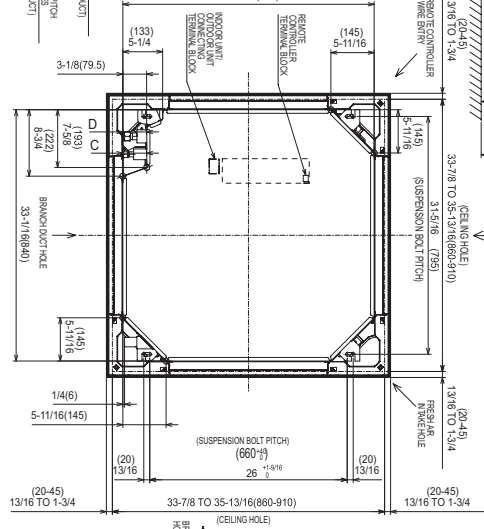
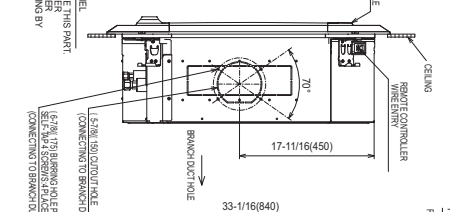
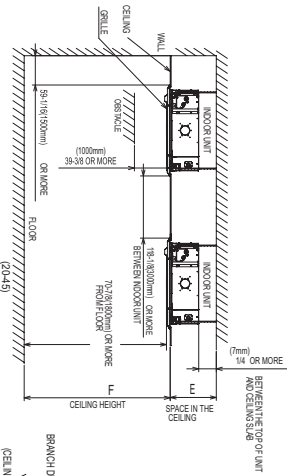
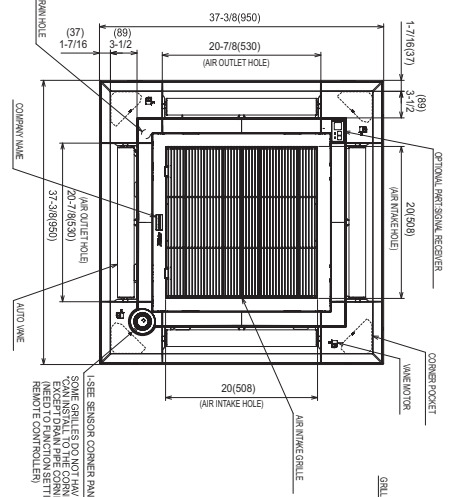

MODELS	①	②	A	B	C	D	E	F
REGULATED PREHEAT	REGULATED PREHEAT	REGULATED PREHEAT	4-1/2 (113)	10-3/8 (268)	10-1/2 (267)	10-1/2 (267)	10-1/2 (267)	10-1/2 (267)
NON-REGULATED PREHEAT	NON-REGULATED PREHEAT	NON-REGULATED PREHEAT	4-1/2 (113)	10-3/8 (268)	10-1/2 (267)	10-1/2 (267)	10-1/2 (267)	10-1/2 (267)
NON-REGULATED PREHEAT	NON-REGULATED PREHEAT	NON-REGULATED PREHEAT	4-1/2 (113)	10-3/8 (268)	10-1/2 (267)	10-1/2 (267)	10-1/2 (267)	10-1/2 (267)

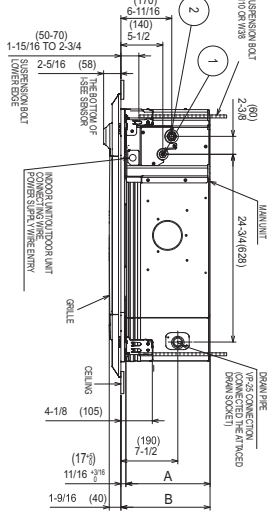
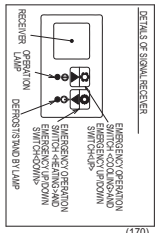

OUTDOOR UNIT DIMENSIONS: PUY-A18NKA7(-BS)

Unit: mm<in>

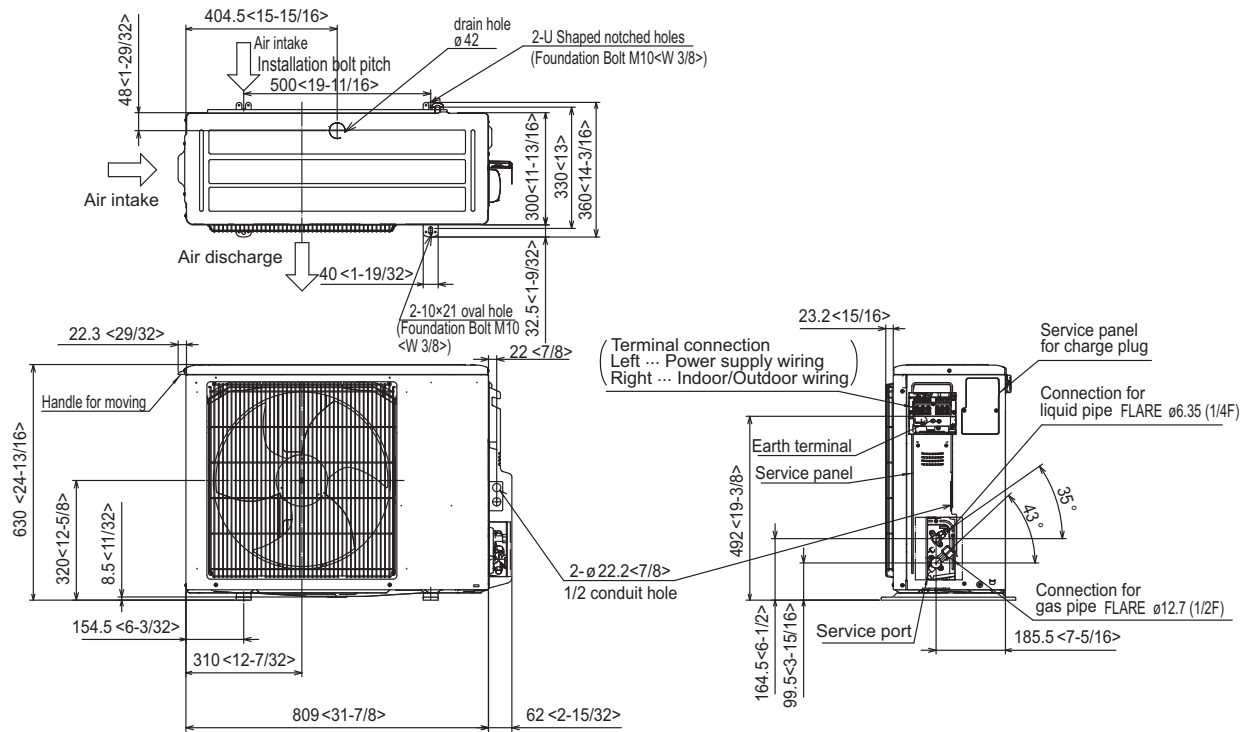

Free space around the outdoor unit (basic example)

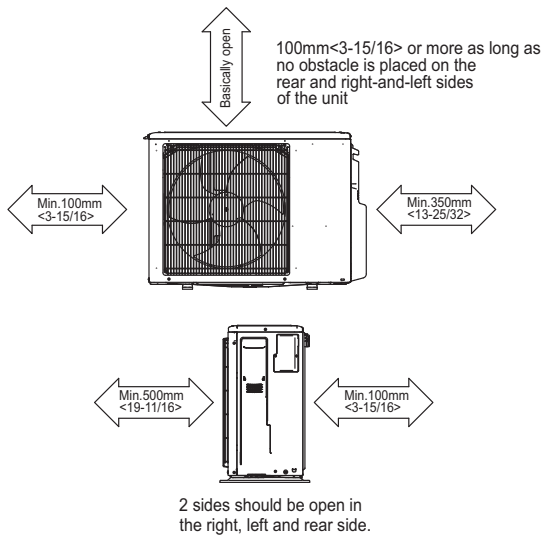

FOUNDATION BOLTS

Please secure the unit firmly with 4 foundation (M10<W3/8>) bolts. (Bolts, washers and nut must be purchased locally).

<Foundation bolt height>

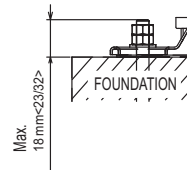

PIPING-WIRING DIRECTION

Piping and wiring connection can be made from the rear direction only.