

INSTALLATION AND OPERATING INSTRUCTIONS FOR HORIZONTAL TWO-WAY COILS (CH SERIES)

IMPORTANT

“The United States Environmental Protection Agency (EPA) has issued various regulations regarding the introduction and disposal of refrigerants in this unit. Failure to follow these regulations may harm the environment and can lead to the imposition of substantial fines. These regulations may vary by jurisdiction. A certified technician must perform the installation and service of this product. Should you have any questions, please contact the local office of the EPA.”

This product is designed and manufactured to permit installation in accordance with national codes. It is the installers responsibility to install this unit in accordance with national codes and / or prevailing local codes and regulations.

APPLICATION INFORMATION



FIGURE 1:

(Front View for right & left hand application)

1. Coil must be installed upstream (discharge side) of the furnace. This is a bi-directional coil and can be installed in either direction. Determine the coil direction by the side that allows the best access.
2. If the furnace and coil are not similar in depth and width, a field-supplied transition can be used to center the furnace and coil openings. An attachment bracket (Z-bracket) has been included to attach the coil to a narrower Goodman or Amana furnace when the furnace is one size smaller than the coil (i.e. coil height = 17.5-inches and furnace width = 14-inches) (See figure 3).
3. To reverse from right to left application, relocate the front rail to the back, and the back rail to the front. Then attach flanges to the discharge side of the unit.

ATTACHING THE DUCT FLANGE

FIGURE 2:

(Horizontal right application)

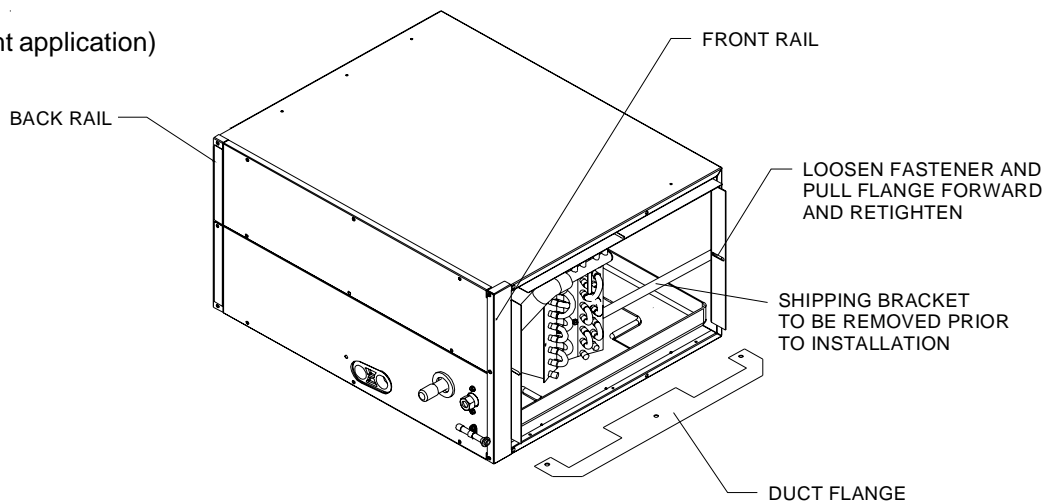

Made in the USA by:

Goodman Manufacturing Company, L.P.

2550 North Loop West, Suite 400, Houston, TX 77092

www.goodmanmfg.com or amana-hac.com

© 2004-2006 Goodman Manufacturing Company, L.P.

- Remove the shipping bracket spanning the A-Coil apex to the rear of the wrapper on all models prior to installation.
- The bottom duct flange for the supply plenum side is shipped unattached. Carefully insert the flange into bottom rail and use a 5/16" screw to attach at the middle of the flange.
- Attach coil to the furnace using hardware and brackets provided. (see Figure 3)
- Attach plenum to coil. (see Figure 3)
- Use tape or mastic to seal between coil and furnace, and also between coil and plenum.

FIGURE 3
(Installation of Furnace, Coil, and Plenum)

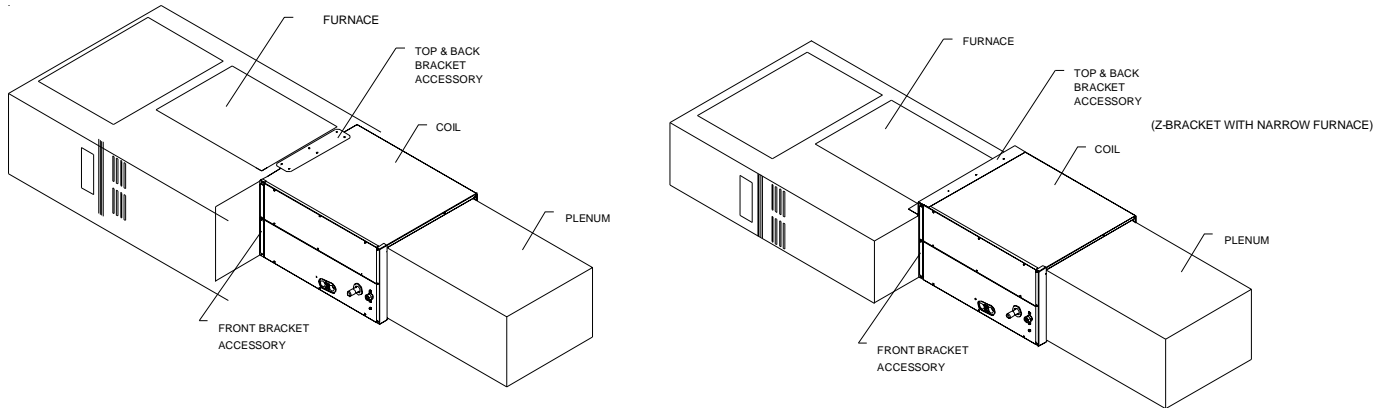

Condensate Drain Piping - When coils are installed above ceilings, or in other locations where damage from condensate overflow may occur, it is MANDATORY to install a field fabricated auxiliary drain pan under the coil cabinet enclosure. Drain lines from the auxiliary pan must be installed and terminated so that the homeowner can see water discharges. A primary condensate drain connection is located in the drain pan on the bottom of the coil / enclosure assembly. The female (3/4 fpt) threaded fitting that protrudes outside of the enclosure is used for external connection.

- Ensure drainpan hole is NOT obstructed.
- To prevent potential sweating and dripping on to finished space, it may be necessary to insulate the condensate drain line located inside the building. Use Armaflex® or similar material.
- A Secondary Condensate Drain Connection, now called for by many building codes, has been provided.
- The drain lines are to be pitched 1/4" per foot to provide free drainage. Insulate drain lines to prevent sweating. Trapped lines are required by many local codes. In absence of any prevailing local codes, reference requirement from the Uniform Mechanical Building Code.
- NOTE: If secondary drain is not installed, the secondary access must be plugged.

FIGURE 4
(Drain Piping Installation)

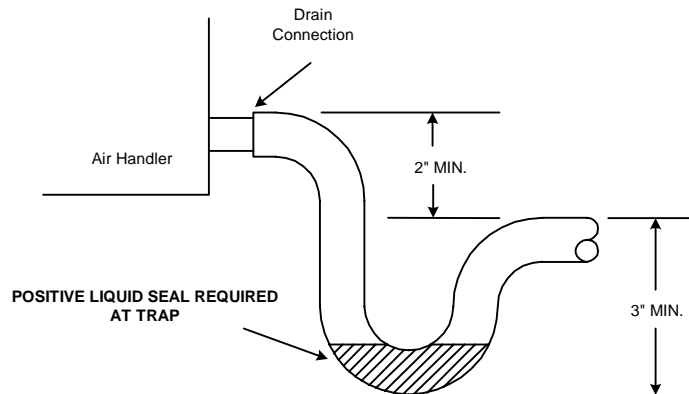



WARNING

DO NOT USE THIS COIL ON **OIL** FURNACES OR ANY APPLICATIONS WHERE THE TEMPERATURE ON DRAIN PAN MAY EXCEED 300°F. A FIELD FABRICATED METAL DRAIN PAN SHOULD BE USED FOR THESE TYPES OF APPLICATIONS. FAILURE TO FOLLOW THIS WARNING MAY RESULT IN PROPERTY DAMAGE AND/OR PERSONAL INJURY.

SPECIAL INSTRUCTIONS

This indoor coil contains the flowrator distributor assembly, which consists of a nut, distributor body, copper tubes feeding the coil, and the internal flow check piston. It is essential that the indoor and outdoor sections be properly matched. When matching the indoor coil with other than the matching outdoor section, the flow check piston in the indoor section **MUST** be changed to match with the outdoor section to obtain the rated performance as specified in our sales specification sheets. If a piston size is **too small**, it causes **starving**; if it is **too large**, it causes **flooding**. When using a combination that requires a different piston size, change the piston in the distributor on the indoor coil before installing the coil, and follow the procedure shown below.

1. Loosen the 13/16 nut **1 turn only** to allow the high pressure tracer gas to escape. No gas indicates a possible leak.
2. After the gas has escaped, remove the nut and discard the cap.
3. Use a tube cutter to remove the spin closure on the suction connection.
4. Remove the tail piece clamped to the exterior and **slide the 13/16 nut in place**.
5. Braze the tail piece to the line set liquid tube.
6. Insert the suction line into the connection, slide the insulation and the rubber grommet at least 18" away from the braze joint.
7. **After the tail piece has cooled**, insert the seal and hand tighten the 13/16 nut.
8. Torque the 13/16 nut 10-30 ft/ lbs. or tighten 1/6 turn.
9. Replace suction line grommet and insulation.



CAUTION

EXCESSIVE TORQUE CAN CAUSE ORIFICES TO STICK. USE THE PROPER TORQUE SETTINGS WHEN TIGHTENING ORIFICES.

Check fittings for leaks after complete installation. Evacuate and charge on the low side.

NOTE: With piston in distributor, the seal end should be pointing inside the distributor body and should not be seen when looking into the end of distributor. Make sure the piston is free to rotate, and move up and down in the distributor body.

IMPORTANT

NOTE (#2) IN THE PISTON KIT CHART (PKC-XX) WILL NOT APPLY TO CH COILS. PISTON KIT NOT INCLUDED WITH CH COILS. IT MUST BE PURCHASED FROM DISTRIBUTOR.

**NOTE: SPECIFICATIONS AND PERFORMANCE DATA LISTED
HEREIN ARE SUBJECT TO CHANGE WITHOUT NOTICE**

Quality Makes the Difference!

All of our systems are designed and manufactured with the same high quality standards regardless of size or efficiency. We have designed these units to significantly reduce the most frequent causes of product failure. They are simple to service and forgiving to operate. We use quality materials and components. Finally, every unit is run tested before it leaves the factory. That's why we know. . . **There's No Better Quality.**

Visit our websites at www.goodmanmfg.com or amana-hac.com for information on:

- Products
- Warranties
- Customer Services
- Parts
- Contractor Programs and Training
- Financing Options