

WATER SOURCE heat pumps

Our **ENERGY MISER** series is recognized as the most efficient and economical way to meet all your Cooling and Heating needs.

Available in Vertical, Split, Horizontal, and Counterflow configuration 1/2 to 6 tons. The **EM Series** is our Premiere product line specifically designed for Cooling Tower / Boiler Systems, Well Water Systems, and now with a "Low Temperature Option" for Geothermal Applications.

Even during temperature extremes, FHP equipment maintains its superior efficiencies. There'll be no nasty surprises during hot summer days or frigid winter nights.



UP TO
21.0
EER

UP TO
4.9
COP

● Environmentally Safe

Unlike air source equipment the **EM Series**, when used on Well Water systems, utilizes the earth's natural ability to conserve & store energy while helping reduce pollution.

● Real Cost Savings

Save from 50% to 70% in heating costs and up to 40% in cooling costs... Plus you can get low cost HOT WATER during the summer months with our Heat Recovery option.

● Reliability

With over 30 years of experience in heat pump technology behind every FHP unit, you can be sure of a quality product that will give you many years of trouble free service.

EM SERIES MODELS 007-070

VERTICAL



HORIZONTAL

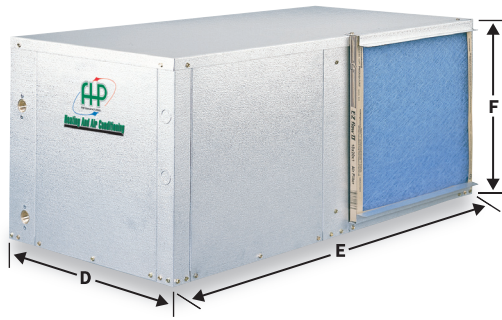

COUNTERFLOW



DIMENSIONS

MODEL	VERTICAL / C. FLOW			HORIZONTAL		
	A	B	C	D	E	F
EM007, 009, 012	19.00	19.00	24.25	19.00	31.00	11.25
EM015, 018	21.50	21.50	32.75	21.50	43.00	17.00
EM024	21.50	21.50	36.25	21.50	43.00	19.00
EM028, 031	21.50	21.50	39.25	22.00	45.00	19.00
EM036, 042	21.50	26.00	43.25	22.00	54.50	19.00
EM041	21.50	21.50	39.25	21.50	43.00	22.00
EM048, 060	24.00	32.50	45.25	36.00	43.00	21.00
EM051*, 061*	26.00	26.00	43.25	N/A	N/A	N/A
EM070	26.00	33.25	58.25	26.00	78.00	21.50

All ratings & specifications are subject to change without notice.
* only available in vertical configurations.

ARI / ISO 13256-1 PERFORMANCE DATA

MODEL	CFM	ENTERING WATER TEMPERATURES											
		Water Loop				Ground Water				*Ground Loop			
		86°F		68°F		59°F		50°F		77°F		32°F	
		COOLING CAPACITY (WLHP)	EER (WLHP)	HEATING CAPACITY (WLHP)	COP (WLHP)	COOLING CAPACITY (GWHP)	EER (GWHP)	HEATING CAPACITY (GWHP)	COP (GWHP)	COOLING CAPACITY (GLHP)	EER (GLHP)	HEATING CAPACITY (GLHP)	COP (GLHP)
EM007	300	7,300	12.3	10,000	4.7	8,500	17.3	7,500	3.8	7,500	13.6	5,500	3.2
EM009	350	9,800	12.0	13,000	4.6	11,400	17.2	9,800	3.7	10,000	13.2	7,200	3.0
EM012	400	11,500	11.2	14,500	4.2	13,000	15.7	11,000	3.2	11,800	12.2	8,200	2.7
EM015	500	14,500	11.5	20,000	4.2	16,500	16.5	15,000	3.4	14,800	12.7	11,000	2.8
EM018	650	18,000	12.5	22,000	4.4	21,000	17.0	17,500	3.8	19,000	13.4	13,000	3.2
EM024	850	23,000	14.0	29,000	4.9	26,000	21.0	23,000	4.2	24,000	15.5	17,000	3.5
EM028	950	28,000	13.1	32,000	4.7	32,000	18.9	26,000	4.0	29,500	14.6	19,000	3.3
EM031	1000	32,000	13.3	40,000	4.7	37,000	19.1	31,500	3.7	34,500	14.7	23,500	3.0
EM036	1200	34,000	14.0	40,000	4.7	38,000	20.1	31,500	4.0	35,000	15.3	23,500	3.4
EM041	1150	38,500	12.5	49,000	4.3	41,000	16.2	39,000	3.8	39,000	13.3	28,000	3.2
EM042	1500	41,500	12.8	50,500	4.3	44,000	16.9	40,000	3.9	42,500	13.6	30,000	3.2
EM048	1600	48,000	12.2	61,000	4.6	58,000	18.0	49,000	4.0	51,000	13.4	38,000	3.4
EM051	1500	47,500	12.8	62,000	4.6	54,000	18.0	49,500	4.0	50,000	14.4	37,500	3.5
EM060	2000	60,000	12.5	77,000	4.5	65,000	17.5	60,000	4.0	60,500	14.0	48,000	3.2
EM061	1800	58,000	13.3	70,000	4.5	62,000	19.0	57,000	4.0	60,000	15.2	45,000	3.4
EM070	2200	68,000	12.5	82,000	4.6	76,000	18.7	66,000	3.8	69,000	13.9	53,000	3.4

Tabulated performance data is at noted entering water temperatures and entering air conditions of 80.6° F DB/66.2° F WB at ARI/ISO 13256-1 rated CFM

* Ground Loop application requires LOW TEMPERATURE OPTION when ordered for the EM Series to function below 50° F entering fluid temps

 ENERGY STAR RATED



GEOEXCHANGE
Saving from the ground up™



ARI Standard 13256-1



PERFORMANCE DATA

FHP MANUFACTURING COMPANY

601 N.W. 65TH COURT • FT. LAUDERDALE, FL 33309 • PHONE: (954) 776-5471 • FAX: (800) 776-5529

<http://www.fhp-mfg.com>

heat pumps

970-105 Rev. 10/08



GUIDE SPECIFICATIONS

EM Series 1/2-6 Ton

GENERAL

Units shall be performance certified to ISO standard 13256-1 for Water Loop Heat Pump, Ground Water Heat Pump and Ground Loop Heat Pump applications. Units intended for use on ground loop applications shall have an optional extended range package installed. Units shall be Underwriter Laboratories (UL and cUL) listed for safety on all models. Each unit shall be run tested at the factory. Each unit shall be pallet mounted and stretch wrapped. The units shall be manufactured in an ISO9001:2000 certified facility.

The units shall be warranted by the manufacturer against defects in materials and workmanship for a period of one year on all parts, and 5 years on the compressor.

The units shall be designed to operate with entering fluid temperatures between 50°F (10°C) and 100°F (38°C) in cooling and between 50°F (10°C) and 80°F (27°C) in heating. With the optional factory installed extended range package units shall operate with entering fluid temperatures between 50°F (10°C) and 110°F (43.3°C) in cooling and between 25°F (-3.9°C) and 80°F (27°C) in heating.

CASING & CABINET

The cabinet shall be fabricated from heavy-gauge steel finished with Galvalume® plus, an aluminum-zinc alloy with a clear acrylic coating for additional corrosion protection. The interior shall be insulated with ½" (12.7mm) thick, multi density, coated, glass fiber. All units shall allow sufficient service access to replace the compressor without unit removal. One blower and two compressor compartment access panels shall be removable with supply and return ductwork in place. A duct collar shall be provided on the supply air opening. A 2" (50.8mm) return air filter rack/duct collar with 1" (25.4mm) thick filters shall be provided with each unit. The units shall have an insulated divider panel between the air handling section and the compressor section to minimize the transmission of compressor noise, and to permit service testing without air bypass. Units shall have a stainless steel condensate drain pan.

REFRIGERATION CIRCUITS

All units shall contain a sealed refrigerant circuit including a hermetic compressor, capillary tube metering device with strainer or balance port expansion valve, finned tube air-to-refrigerant heat exchanger, refrigerant reversing valve and service ports. Compressor shall be high efficiency, designed for heat pump duty, internally spring isolated (if reciprocating type) for maximum sound attenuation and mounted on rubber vibration isolators. Compressor motors shall be equipped with overload protection. Refrigerant reversing valves shall be pilot operated sliding piston type with replaceable encapsulated magnetic coils energized only during the cooling cycle. The finned tube coil shall be constructed of lanced aluminum fins not exceeding fourteen fins per inch bonded to rifled copper tubes in a staggered pattern not less than three rows deep and have a 450 PSIG (3100 kPa) working pressure. Coils shall have a baked polyester enamel coating for protection against most airborne chemicals. The coil shall have aluminum end sheets. The coaxial water-to-refrigerant heat exchanger shall be constructed of a convoluted copper (optional cupronickel) inner tube and steel outer tube with a designed refrigerant working pressure of 450 PSIG (3100 kPa) and designed water side working pressure of no less than 400 PSIG (2750 kPa).

EXTENDED RANGE PACKAGE

An optional extended range package shall include a bi-flow balanced port expansion valve metering device in place of capillary tubes and insulated water to refrigerant heat exchanger.

FAN MOTOR & ASSEMBLY

The fan shall be direct drive centrifugal forward curved type with a dynamically balanced wheel. The housing and wheel shall be designed for quiet low velocity operation. The fan housing shall be removable from the unit without disconnecting the supply air ductwork for servicing of the fan motor. The fan motor shall be three speed PSC type for direct drive units and single speed for belt drive units. The motor shall be permanently lubricated and have thermal overload protection.

ELECTRICAL

Controls and safety devices will be factory wired and mounted within the unit. Controls shall include fan relay, compressor contactor, 24V transformer, reversing valve coil and solid state lockout controller (UPM) The UPM controller shall include the following features: Anti-short cycle time delay, random start, brown out/surge/power interruption protection, 120 second low pressure switch bypass timer, shutdown on high or low refrigerant pressure safety switch inputs, shutdown for the optional freezestat or high level condensate sensors, 24 VAC alarm output for remote fault indication, unit reset at thermostat or disconnect, ability to defeat time delays for servicing and automatic intelligent reset. The UPM shall automatically reset after a safety shut down and restart the unit, if the cause of the shut down no longer exists, after the anti-short cycle and random start timers expire. Should a fault re-occur within 60 minutes after reset, then a permanent lockout will occur. A light emitting diode (LED) shall announce the following alarms: high refrigerant pressure, low refrigerant pressure, low water temperature and a high level of condensate in the drain pan (when equipped with the optional low water temperature and high level condensate sensors). The LED will display each fault condition as soon as the fault occurs. If a permanent lockout occurs, then the fault LED will display the type of fault until the unit is reset.

Safety devices include a low pressure cutout set a 20 PSIG (140 kPa) for loss of charge protection (freezestat and/or high discharge gas temperature sensor is not acceptable) and a high pressure cutout control set at 380 PSIG (2600 kPa). An optional energy management relay that allows unit control by an external source shall be factory installed.

A terminal block with screw terminals shall be provided for control wiring.

PIPING

Supply, return water and condensate drain connections shall be brass female pipe thread fittings and mounted flush to cabinet exterior with optional stainless steel, braided hose kit with swivel connectors.



FHP Manufacturing Co.
 601 N.W. 65th Court
 Fort Lauderdale, FL 33309
 Phone: (954) 776-5471
 Fax: (800) 776-5529
<http://www.fhp-mfg.com>

EM Series Vertical Dimensions

MODEL	A	B	C	D	E	F	G	H	J	K	M	N	P	Q	Condenser Water Connections	Recommended Replacement Nominal Filter Size
	Width	Depth	Height								R/A Duct Flg Width	R/A Duct Flg Height	Filter Rack Height			
EM007, 009	19.00	19.00	24.25	11.75	7.75	3.50	8.25	2.38	4.88	7.38	15.00	8.00	10.00	8.25	3/4" F.P.T.	10 X 16 X 1
EM012	19.00	19.00	24.25	11.75	7.75	3.50	9.75	2.38	4.88	7.38	15.00	8.00	10.00	5.00	3/4" F.P.T.	10 X 16 X 1
EM015	21.50	21.50	32.25	11.75	9.75	5.88	7.88	2.38	7.38	13.25	17.50	14.00	16.00	7.88	3/4" F.P.T.	16 X 20 X 1
EM018	21.50	21.50	32.25	16.25	13.75	1.75	5.62	2.38	7.38	13.25	17.50	14.00	16.00	5.62	3/4" F.P.T.	16 X 20 X 1
EM024	21.50	21.50	36.25	16.25	13.75	1.75	5.62	2.38	7.38	12.50	17.50	16.00	18.00	5.62	3/4" F.P.T.	18 X 20 X 1
EM028	21.50	21.50	39.25	16.25	13.75	1.75	5.62	2.38	7.38	12.50	17.50	18.00	20.00	5.62	3/4" F.P.T.	20 X 20 X 1
EM031	21.50	21.50	39.25	16.25	13.75	1.75	5.62	2.38	7.38	13.50	17.50	18.00	20.00	5.62	3/4" F.P.T.	20 X 20 X 1
EM036	21.50	26.00	43.25	16.25	15.75	4.75	5.00	2.38	8.38	14.75	22.00	22.00	24.00	5.00	3/4" F.P.T.	24 X 24 X 1
EM041	21.50	21.50	39.25	16.25	13.75	1.75	5.62	2.38	8.38	14.75	17.50	18.00	20.00	5.62	3/4" F.P.T.	20 X 20 X 1
EM042	21.50	26.00	43.25	16.25	15.75	4.75	5.00	2.38	8.38	14.75	22.00	22.00	24.00	5.00	3/4" F.P.T.	24 X 24 X 1
EM048	24.00	32.50	45.25	17.75	17.75	7.38	5.12	2.63	8.38	14.75	28.00	22.00	24.00	5.12	1" F.P.T.	24 X 30 X 1
EM051	26.00	26.00	43.25	17.75	17.75	2.12	7.12	2.38	6.25	9.75	22.00	28.00	30.00	7.12	1" F.P.T.	24 X 30 X 1
EM060	24.00	32.50	45.25	17.75	17.75	7.38	5.12	3.00	9.63	16.63	28.00	22.00	24.00	5.12	1" F.P.T.	24 X 30 X 1
EM061	26.00	26.00	43.25	17.75	17.75	2.12	7.12	2.38	6.25	9.75	22.00	28.00	30.00	7.12	1" F.P.T.	24 X 30 X 1
EM070	26.00	33.25	58.25	17.75	17.75	9.50	6.50	3.38	8.38	17.38	28.00	30.00	32.00	6.50	1" F.P.T.	16 X 30 X 1 (2)

Left Hand Return (FLT)

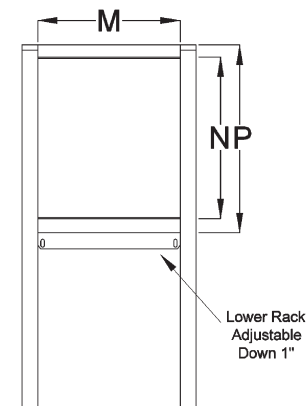
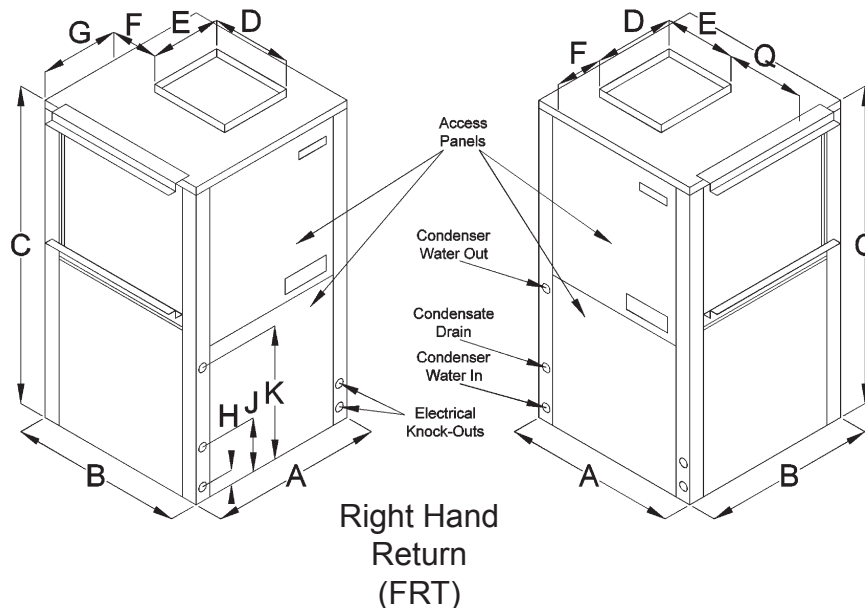

NOTES: All dimensions within +/- 0.125".
 All condensate drain connections are 3/4" FPT.
 EM051 and 061 only available in vertical configuration.
 Specifications subject to change without notice.



FHP Manufacturing Co.
 601 N.W. 65th Court
 Fort Lauderdale, FL 33309
 Phone: (954) 776-5471
 Fax: (800) 776-5529
<http://www.fhp-mfg.com>

EM Series Horizontal Dimensions

MODEL	A	B	C	D	E	F	G	H	J	K	M	N	P	Q	R	T	Condenser Water Connections	Recommended Replacement Nom. Filter Size
	Width	Depth	Height		R/A Duct Flg Width									Filter Rack Height	R/A Duct Flg Height			
EM007, 009	19.00	31.00	11.25	2.00	15.00	14.00	2.38	7.38	2.25	11.75	1.25	7.75	2.25	1.88	10.00	8.00	3/4" F.P.T.	10 X 16 X 1
EM012	19.00	31.00	11.25	2.00	15.00	14.00	2.38	7.38	2.50	11.75	1.25	7.75	2.25	1.88	10.00	8.00	3/4" F.P.T.	10 X 16 X 1
EM015	21.50	43.00	17.00	2.00	17.50	23.50	2.38	13.25	4.00	11.75	1.25	9.75	2.25	1.88	16.00	14.00	3/4" F.P.T.	16 X 20 X 1
EM018	21.50	43.00	17.00	2.00	17.50	23.50	2.38	13.25	3.50	11.75	1.25	13.75	3.50	1.75	16.00	14.00	3/4" F.P.T.	16 X 20 X 1
EM024	21.50	43.00	19.00	2.00	17.50	23.50	2.38	12.50	3.25	11.75	3.25	13.75	3.25	1.75	18.00	16.00	3/4" F.P.T.	18 X 20 X 1
EM028	22.00	45.00	19.00	2.00	19.50	23.50	2.38	12.50	2.50	13.75	1.50	15.75	2.50	1.50	18.00	16.00	3/4" F.P.T.	18 X 20 X 1
EM031	22.00	45.00	19.00	2.00	19.50	23.50	2.38	13.50	2.50	13.75	1.50	15.75	2.50	1.50	18.00	16.00	3/4" F.P.T.	18 X 20 X 1
EM036	22.00	54.50	19.00	2.00	29.00	23.50	2.38	14.75	2.50	13.75	1.50	15.75	2.50	1.50	18.00	16.00	3/4" F.P.T.	18 X 30 X 1
EM041	21.50	43.00	22.00	2.00	17.50	23.50	2.38	14.75	2.50	13.75	3.00	15.75	3.25	3.00	20.00	18.00	3/4" F.P.T.	20 X 20 X 1
EM042	22.00	54.50	19.00	2.00	29.00	23.50	2.38	14.75	2.50	13.75	1.50	15.75	2.50	1.50	18.00	16.00	3/4" F.P.T.	18 X 30 X 1
EM048	36.00	43.00	21.00	2.25	33.75	7.00	2.63	14.75	10.13	15.75	2.50	15.75	3.00	2.50	20.00	18.00	1" F.P.T.	18 X 20 X 1 (2)
EM060	36.00	43.00	21.00	2.25	33.75	7.00	3.00	16.63	10.13	15.75	1.50	17.75	3.25	1.50	20.00	18.00	1" F.P.T.	18 X 20 X 1 (2)
EM070	26.00	78.00	21.50	2.50	44.00	31.50	3.12	18.50	2.75	17.75	2.75	17.75	2.75	1.25	20.50	18.50	1" F.P.T.	20 X 24 X 1 (2)

Left Hand Return
 (Note: Models EM048 & 060 Left Hand Return units have condenser water connections on the front right and electrical knockouts on the front left.)

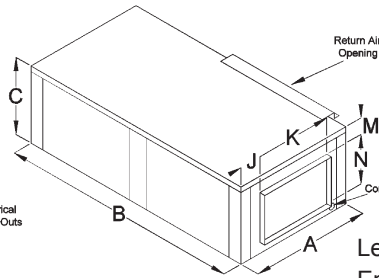
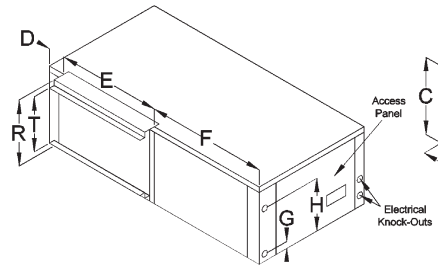

Left Hand Return End Blow (FLE)

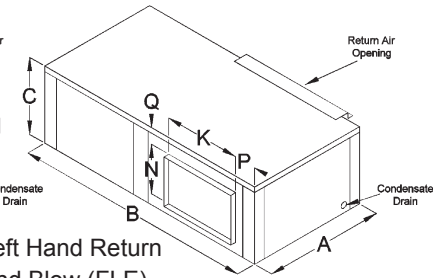

Left Hand Return Straight Through (FLS)

Right Hand Return

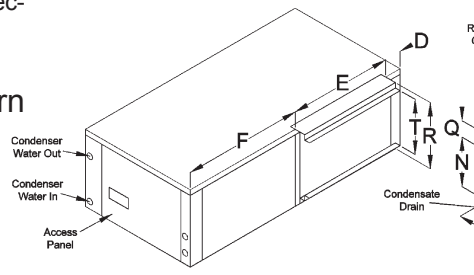

Right Hand Return End Blow (FRE)

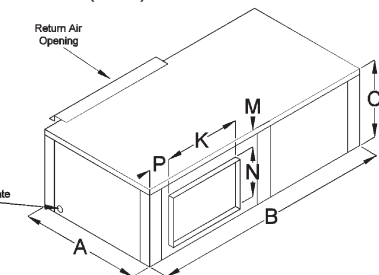
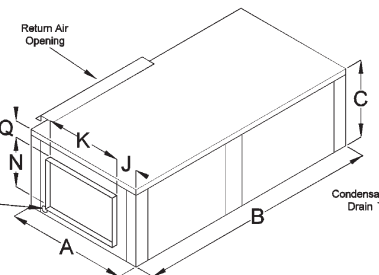

Right Hand Return Straight Through (FRS)

NOTES: All dimensions within +/- 0.125". All condensate drain connections are 3/4" FPT. Specifications subject to change without notice. EM015-070 can be field converted between end blow and straight through supply air configurations



FHP Manufacturing Co.
 601 N.W. 65th Court
 Fort Lauderdale, FL 33309
 Phone: (954) 776-5471
 Fax: (800) 776-5529
<http://www.fhp-mfg.com>

EM Series Counterflow Dimensions

MODEL	A	B	C	D	E	F	G	H	J	K	M	N	P	Condenser Water Connections	Recommended Replacement Nominal Filter Size
	Width	Depth	Height	Blower Opening	Blower Opening						R/A Duct Flg Width	R/A Duct Flg Height	Filter Rack Height		
EM007, 009	19.00	19.00	24.25	6.25	4.25	6.00	10.25	5.00	10.00	10.25	15.00	8.00	10.00	3/4" F.P.T.	10 X 16 X 1
EM012	19.00	19.00	24.25	5.25	4.00	7.00	12.38	5.00	10.00	7.75	15.00	8.00	10.00	3/4" F.P.T.	10 X 16 X 1
EM015	21.50	21.50	32.25	6.25	4.25	6.50	12.00	5.88	16.75	12.00	17.50	14.00	16.00	3/4" F.P.T.	16 X 20 X 1
EM018	21.50	21.50	32.25	9.63	9.25	8.13	8.00	5.88	16.75	8.00	17.50	14.00	16.00	3/4" F.P.T.	16 X 20 X 1
EM024	21.50	21.50	36.25	9.63	9.25	8.13	8.00	5.88	16.00	8.00	17.50	16.00	18.00	3/4" F.P.T.	18 X 20 X 1
EM028	21.50	21.50	39.25	9.63	9.25	8.13	8.00	5.88	16.00	8.00	17.50	18.00	20.00	3/4" F.P.T.	20 X 20 X 1
EM031	21.50	21.50	39.25	9.63	9.25	8.13	8.00	4.88	16.00	8.00	17.50	18.00	20.00	3/4" F.P.T.	20 X 20 X 1
EM036	21.50	26.00	43.25	10.25	9.25	10.00	8.75	4.38	16.75	8.75	22.00	22.00	24.00	3/4" F.P.T.	24 X 24 X 1
EM041	21.50	21.50	39.25	10.25	9.25	7.25	7.75	4.38	16.75	7.75	17.50	18.00	20.00	3/4" F.P.T.	20 X 20 X 1
EM042	21.50	26.00	43.25	10.25	9.25	10.00	8.75	4.38	16.75	8.75	22.00	22.00	24.00	3/4" F.P.T.	24 X 24 X 1
EM048	24.00	32.50	45.25	11.75	10.75	9.25	9.00	6.00	18.25	9.00	28.00	22.00	24.00	1" F.P.T.	24 X 30 X 1
EM060	24.00	32.50	45.25	12.50	12.00	9.00	8.00	4.25	17.75	8.00	28.00	22.00	24.00	1" F.P.T.	24 X 30 X 1
EM070	26.00	33.25	58.25	12.00	12.50	10.63	9.00	3.00	18.50	9.00	28.00	30.00	32.00	1" F.P.T.	16 X 30 X 1 (2)

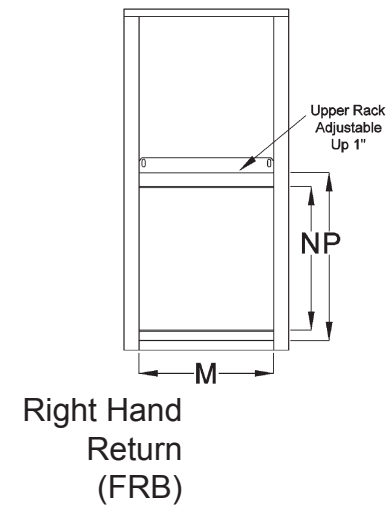
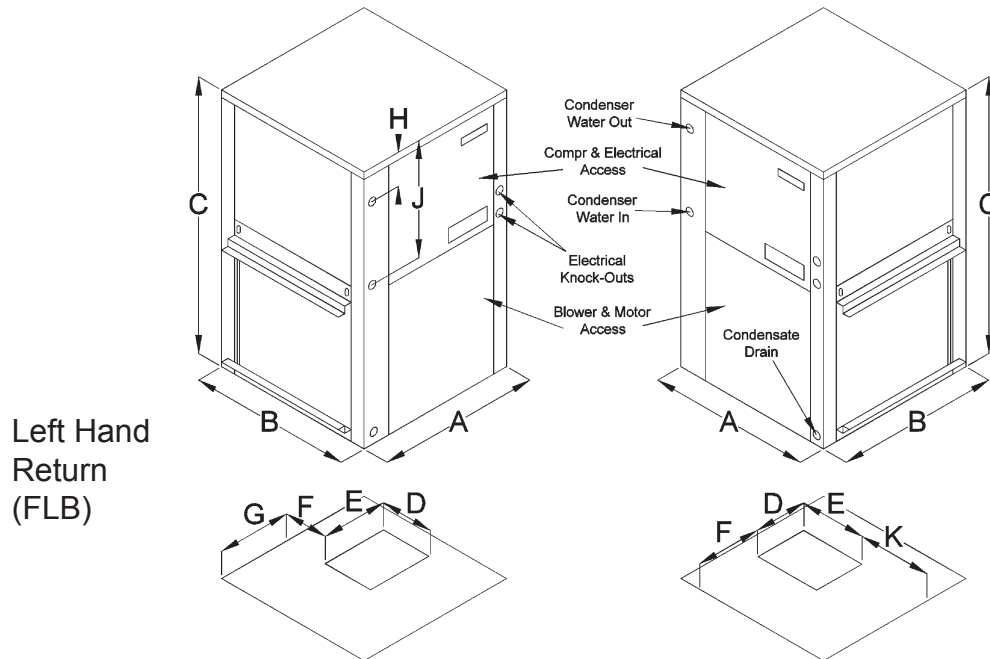

NOTES: All dimensions within +/- 0.125".
 All condensate drain connections are 3/4" FPT.
 Specifications subject to change without notice.



PACKAGED UNITS SPECIFICATION DATA SHEET

FHP MANUFACTURING HIGH-EFFICIENCY WATER SOURCE HEAT PUMPS

EM007

ENERGY-MISER

ELECTRICAL SPECIFICATIONS

Electrical Characteristics	Elect. Symbol	Compressor		Blower		Loop Pump		Min. Circuit Amps	Max. Fuse/Breaker
		RLA	LRA	FLA	HP	FLA	HP		
115-1-60	-0	6.6	29.8	2.2	1/10	-	-	10.5	15
208/230-1-60	-1	3.1	15.9	1.0	1/10	-	-	4.8	15
265-1-60	-2	2.9	12.3	0.9	1/10	-	-	4.5	15

MECHANICAL SPECIFICATIONS

Refrigerant: R-22			
Air Coil			
Square Feet	Rows Deep	Tube O.D.	Fins/Inch
0.90	3	3/8	14
Water Coil			
Type	Work Press		
Coaxial	450 psig		
Blower Size	Compr Type		
4x6 DD	Reciprocating		
Net Weight	Ship Weight		
118 lbs	127 lbs		

BLOWER PERFORMANCE

Available External Static Pressure (Inches of Water, Gauge. Wet Coil and Filter Included)												
Blower Speed	0.10	0.20	0.30	0.40	0.50	0.60	0.70	0.80	0.90	1.00	1.10	1.20
High	410	380	350	315	280	210	-	-	-	-	-	-
Medium	390	360	330	300	260	-	-	-	-	-	-	-
Low	370	340	295	250	-	-	-	-	-	-	-	-



FLUID PRESSURE DROP

Fluid Flow (GPM)	Pressure Drop	
	(FOH)	(PSIG)
1	1.5	0.7
1.5	3.2	1.4
2	5.4	2.3
2.5	8.0	3.5
3	11.1	4.8

ISO 13256-1 CERTIFIED PERFORMANCE DATA Rated at 300 CFM and 2.0 GPM

Water Loop				Ground Water				Ground Loop (Ext. Range Required)			
Cooling		Heating		Cooling		Heating		Cooling		Heating	
Capacity	EER	Capacity	COP	Capacity	EER	Capacity	COP	Capacity	EER	Capacity	COP
7,300	12.3	10,000	4.7	8,500	17.3	7,500	3.8	7,500	13.6	5,500	3.2



CAPACITY DATA All performance at 300 CFM and 2.0 GPM

COOLING							
EFT Range (Standard) 50°F to 100°F				EFT Range (Ext. Range Option) 45°F to 110°F			
Entering Fluid Temp. (°F)	Entering Air Temp. (°F)	Total Capacity (MBtuH)	Sensible Capacity (MBtuH)	Sensible to Total Ratio	Power Input (kW)	Heat of Reject (MBtuH)	EER
50°	70°db 61°wb	7.56	4.99	0.66	0.48	9.20	15.7
60°		7.17	4.77	0.67	0.52	8.94	13.9
70°		6.78	4.57	0.67	0.56	8.68	12.2
85°		6.20	4.29	0.69	0.61	8.29	10.1
100°		5.62	4.03	0.72	0.67	7.90	8.4
50°	75°db 63°wb	8.10	5.97	0.74	0.48	9.75	16.8
60°		7.68	5.71	0.74	0.52	9.46	14.8
70°		7.27	5.47	0.75	0.56	9.18	13.0
85°		6.65	5.13	0.77	0.61	8.75	10.8
100°		6.03	4.82	0.80	0.67	8.32	9.0
50°	80°db 67°wb	8.89	6.59	0.74	0.49	10.55	18.3
60°		8.44	6.30	0.75	0.52	10.23	16.1
70°		7.98	6.04	0.76	0.56	9.90	14.2
85°		7.30	5.67	0.78	0.62	9.42	11.8
100°		6.62	5.32	0.80	0.68	8.93	9.8
50°	85°db 71°wb	9.68	7.22	0.75	0.49	11.35	19.7
60°		9.19	6.91	0.75	0.53	10.99	17.4
70°		8.69	6.62	0.76	0.57	10.63	15.3
85°		7.95	6.21	0.78	0.62	10.08	12.7
100°		7.21	5.83	0.81	0.68	9.54	10.6

HEATING

HEATING					
EFT Range (Standard) 50°F to 80°F			EFT Range (Ext. Range Option) 25°F to 80°F		
Entering Fluid Temp. (°F)	Entering Air Temp. (°F)	Total Capacity (MBtuH)	Power Input (kW)	Heat of Abs. (MBtuH)	COP
50°	60°	8.17	0.59	6.17	4.1
60°		9.44	0.62	7.34	4.5
70°		10.72	0.65	8.51	4.8
80°		11.99	0.68	9.68	5.2
50°		70°	7.72	0.60	5.68
60°	8.93		0.63	6.78	4.2
70°	10.13		0.66	7.88	4.5
80°	11.34		0.69	8.98	4.8
50°	80°		7.20	0.61	5.12
60°		8.32	0.64	6.13	3.8
70°		9.45	0.67	7.14	4.1
80°		10.57	0.71	8.16	4.4

LOW TEMP HEATING

LOW TEMP HEATING					
Extended Range Option Required Antifreeze Required					
Entering Fluid Temp. (°F)	Entering Air Temp. (°F)	Total Capacity (MBtuH)	Power Input (kW)	Heat of Abs. (MBtuH)	COP
25°	60°	4.88	0.51	3.14	2.8
30°		5.51	0.53	3.71	3.1
40°		6.76	0.56	4.86	3.6
25°	70°	4.62	0.52	2.85	2.6
30°		5.21	0.54	3.38	2.9
40°		6.39	0.57	4.46	3.3
25°	80°	4.31	0.53	2.50	2.4
30°		4.86	0.55	2.99	2.6
40°		5.96	0.58	3.99	3.0

Units are complete packages containing compressor, reversing valve, capillary tube metering device, and heat exchangers. Also included are safety controls: Overload protection for motors, high and low refrigerant pressure switches and a lock-out circuit.

Extended range option includes expansion valve metering device, insulated water coil and solid state lock-out controls.

Performance based on ARI/ISO rated air flow, fluid flow and voltage. For conditions other than rated, consult the FHP EAD selection software. Due to variations in installation actual performance may vary marginally from tabulated values.

As a result of continuing research and development, specifications are subject to change without notice.



PACKAGED UNITS SPECIFICATION DATA SHEET

FHP MANUFACTURING HIGH-EFFICIENCY WATER SOURCE HEAT PUMPS

EM009

ENERGY-MISER

ELECTRICAL SPECIFICATIONS

Electrical Characteristics	Elect. Symbol	Compressor		Blower		Loop Pump		Min. Circuit Amps	Max. Fuse/Breaker
		RLA	LRA	FLA	HP	FLA	HP		
115-1-60	-0	8.3	40.0	2.2	1/10	-	-	12.6	20
208/230-1-60	-1	4.0	20.0	1.0	1/10	-	-	6.0	15
265-1-60	-2	3.3	16.0	0.9	1/10	-	-	5.0	15

MECHANICAL SPECIFICATIONS

Refrigerant: R-22			
Air Coil			
Square Feet	Rows Deep	Tube O.D.	Fins/Inch
0.90	3	3/8	14
Water Coil			
Type	Work Press		
Coaxial	450 psig		
Blower Size	Compr Type		
4x6 DD	Reciprocating		
Net Weight	Ship Weight		
120 lbs	129 lbs		

BLOWER PERFORMANCE

Available External Static Pressure (Inches of Water, Gauge. Wet Coil and Filter Included)												
Blower Speed	0.10	0.20	0.30	0.40	0.50	0.60	0.70	0.80	0.90	1.00	1.10	1.20
High	410	380	350	315	280	210	-	-	-	-	-	-
Medium	390	360	330	300	260	-	-	-	-	-	-	-
Low	370	340	295	250	-	-	-	-	-	-	-	-



FLUID PRESSURE DROP

Fluid Flow (GPM)	Pressure Drop	
	(FOH)	(PSIG)
1	1.5	0.7
1.5	3.2	1.4
2	5.4	2.3
2.5	8.0	3.5
3	11.1	4.8

ISO 13256-1 CERTIFIED PERFORMANCE DATA Rated at 350 CFM and 2.5 GPM

Water Loop				Ground Water				Ground Loop (Ext. Range Required)			
Cooling		Heating		Cooling		Heating		Cooling		Heating	
Capacity	EER	Capacity	COP	Capacity	EER	Capacity	COP	Capacity	EER	Capacity	COP
9,800	12.0	13,000	4.6	11,400	17.2	9,800	3.7	10,000	13.2	7,200	3.0

CAPACITY DATA All performance at 350 CFM and 2.5 GPM

COOLING

EFT Range (Standard) 50°F to 100°F
EFT Range (Ext. Range Option) 45°F to 110°F

Entering Fluid Temp. (°F)	Entering Air Temp. (°F)	Total Capacity (MBtuH)	Sensible Capacity (MBtuH)	Sensible to Total Ratio	Power Input (kW)	Heat of Reject (MBtuH)	EER
50°	70°db 61°wb	9.85	6.56	0.67	0.58	11.82	17.1
60°		9.35	6.28	0.67	0.63	11.51	14.8
70°		8.85	6.01	0.68	0.69	11.19	12.9
85°		8.09	5.64	0.70	0.77	10.72	10.5
100°		7.34	5.29	0.72	0.85	10.24	8.6
50°	75°db 63°wb	10.55	7.83	0.74	0.58	12.53	18.2
60°		10.02	7.49	0.75	0.63	12.18	15.8
70°		9.48	7.18	0.76	0.69	11.83	13.7
85°		8.67	6.74	0.78	0.77	11.31	11.2
100°		7.86	6.32	0.80	0.86	10.78	9.2
50°	80°db 67°wb	11.58	8.64	0.75	0.58	13.57	19.8
60°		10.99	8.27	0.75	0.64	13.17	17.2
70°		10.40	7.92	0.76	0.70	12.77	14.9
85°		9.51	7.44	0.78	0.78	12.17	12.2
100°		8.63	6.98	0.81	0.86	11.57	10.0
50°	85°db 71°wb	12.60	9.46	0.75	0.59	14.61	21.4
60°		11.96	9.05	0.76	0.65	14.16	18.5
70°		11.32	8.67	0.77	0.70	13.71	16.1
85°		10.36	8.14	0.79	0.79	13.04	13.2
100°		9.39	7.64	0.81	0.87	12.36	10.8

HEATING

EFT Range (Standard) 50°F to 80°F
EFT Range (Ext. Range Option) 25°F to 80°F

Entering Fluid Temp. (°F)	Entering Air Temp. (°F)	Total Capacity (MBtuH)	Power Input (kW)	Heat of Abs. (MBtuH)	COP
50°	60°	10.43	0.76	7.83	4.0
60°		12.05	0.80	9.33	4.4
70°		13.66	0.83	10.83	4.8
80°		15.28	0.86	12.33	5.2
50°		70°	9.86	0.78	7.21
60°	11.39		0.81	8.62	4.1
70°	12.91		0.84	10.03	4.5
80°	14.44		0.88	11.44	4.8
50°	80°		9.19	0.79	6.48
60°		10.61	0.83	7.78	3.8
70°		12.03	0.86	9.09	4.1
80°		13.46	0.90	10.39	4.4

LOW TEMP HEATING

Extended Range Option Required
Antifreeze Required

25°	60°	6.26	0.68	3.95	2.7
30°		7.06	0.69	4.69	3.0
40°		8.64	0.73	6.16	3.5
25°	70°	5.92	0.69	3.57	2.5
30°		6.67	0.71	4.26	2.8
40°		8.17	0.74	5.64	3.2
25°	80°	5.52	0.70	3.12	2.3
30°		6.22	0.72	3.75	2.5
40°		7.61	0.76	5.03	2.9

Units are complete packages containing compressor, reversing valve, capillary tube metering device, and heat exchangers. Also included are safety controls: Overload protection for motors, high and low refrigerant pressure switches and a lock-out circuit.

Extended range option includes expansion valve metering device, insulated water coil and solid state lock-out controls.

Performance based on ARI/ISO rated air flow, fluid flow and voltage. For conditions other than rated, consult the FHP EAD selection software. Due to variations in installation actual performance may vary marginally from tabulated values.

As a result of continuing research and development, specifications are subject to change without notice.

FHP MANUFACTURING COMPANY

601 N.W. 65th Court - Fort Lauderdale, FL 33309

Phone: (954) 776-5471 - Fax: (800) 776-5529

<http://www.fhp-mfg.com>



PACKAGED UNITS SPECIFICATION DATA SHEET

FHP MANUFACTURING HIGH-EFFICIENCY WATER SOURCE HEAT PUMPS

EM012

ENERGY-MISER

ELECTRICAL SPECIFICATIONS

Electrical Characteristics	Elect. Symbol	Compressor		Blower		Loop Pump		Min. Circuit Amps	Max. Fuse/Breaker
		RLA	LRA	FLA	HP	FLA	HP		
115-1-60	-0	8.3	40.0	2.2	1/10	-	-	12.6	20
208/230-1-60	-1	5.0	31.0	1.0	1/10	-	-	7.2	15
265-1-60	-2	3.3	16.0	0.9	1/10	-	-	5.0	15

MECHANICAL SPECIFICATIONS

Refrigerant: R-22			
Air Coil			
Square Feet	Rows Deep	Tube O.D.	Fins/Inch
0.97	3	3/8	14
Water Coil			
Type	Work Press		
Coaxial	450 psig		
Blower Size	Compr Type		
4x7 DD	Reciprocating		
Net Weight	Ship Weight		
129 lbs	140 lbs		

BLOWER PERFORMANCE

Available External Static Pressure (Inches of Water, Gauge. Wet Coil and Filter Included)												
Blower Speed	0.10	0.20	0.30	0.40	0.50	0.60	0.70	0.80	0.90	1.00	1.10	1.20
High	425	410	390	371	350	325	300	-	-	-	-	-
Medium	410	395	375	355	330	305	-	-	-	-	-	-
Low	385	370	350	330	305	-	-	-	-	-	-	-



FLUID PRESSURE DROP

Fluid Flow (GPM)	Pressure Drop	
	(FOH)	(PSIG)
1.5	3.2	1.4
2	5.3	2.3
2.5	7.9	3.4
3	11.0	4.8
3.5	14.5	6.3

ISO 13256-1 CERTIFIED PERFORMANCE DATA Rated at 400 CFM and 3.0 GPM

Water Loop				Ground Water				Ground Loop (Ext. Range Required)			
Cooling		Heating		Cooling		Heating		Cooling		Heating	
Capacity	EER	Capacity	COP	Capacity	EER	Capacity	COP	Capacity	EER	Capacity	COP
11,500	11.2	14,500	4.2	13,000	15.7	11,000	3.2	11,800	12.2	8,200	2.7

CAPACITY DATA All performance at 400 CFM and 3.0 GPM

COOLING

EFT Range (Standard) 50°F to 100°F
EFT Range (Ext. Range Option) 45°F to 110°F

Entering Fluid Temp. (°F)	Entering Air Temp. (°F)	Total Capacity (MBtuH)	Sensible Capacity (MBtuH)	Sensible to Total Ratio	Power Input (kW)	Heat of Reject (MBtuH)	EER
50°	70°db 61°wb	11.49	7.52	0.65	0.76	14.08	15.1
60°		11.02	7.27	0.66	0.83	13.87	13.2
70°		10.55	7.05	0.67	0.91	13.65	11.6
85°		9.83	6.74	0.69	1.02	13.33	9.6
100°		9.12	6.47	0.71	1.14	13.01	8.0
50°	75°db 63°wb	12.31	8.98	0.73	0.76	14.92	16.1
60°		11.80	8.68	0.74	0.84	14.67	14.1
70°		11.30	8.41	0.74	0.92	14.42	12.3
85°		10.53	8.05	0.76	1.03	14.05	10.2
100°		9.77	7.73	0.79	1.15	13.68	8.5
50°	80°db 67°wb	13.51	9.91	0.73	0.77	16.13	17.6
60°		12.95	9.58	0.74	0.85	15.84	15.3
70°		12.39	9.28	0.75	0.92	15.54	13.4
85°		11.56	8.88	0.77	1.04	15.10	11.1
100°		10.72	8.53	0.80	1.15	14.66	9.3
50°	85°db 71°wb	14.70	10.85	0.74	0.78	17.35	19.0
60°		14.10	10.49	0.74	0.85	17.01	16.5
70°		13.49	10.16	0.75	0.93	16.67	14.5
85°		12.58	9.73	0.77	1.05	16.16	12.0
100°		11.67	9.34	0.80	1.16	15.64	10.0

HEATING

EFT Range (Standard) 50°F to 80°F
EFT Range (Ext. Range Option) 25°F to 80°F

Entering Fluid Temp. (°F)	Entering Air Temp. (°F)	Total Capacity (MBtuH)	Power Input (kW)	Heat of Abs. (MBtuH)	COP
50°	60°	11.91	0.99	8.52	3.5
60°		13.69	1.05	10.12	3.8
70°		15.47	1.10	11.71	4.1
80°		17.25	1.16	13.31	4.4
50°	70°	11.26	1.01	7.81	3.3
60°		12.94	1.07	9.30	3.6
70°		14.62	1.12	10.80	3.8
80°		16.31	1.18	12.29	4.1
50°	80°	10.49	1.03	6.96	3.0
60°		12.06	1.09	8.34	3.2
70°		13.62	1.15	9.71	3.5
80°		15.19	1.20	11.08	3.7

LOW TEMP HEATING

Extended Range Option Required
Antifreeze Required

25°	60°	7.31	0.86	4.39	2.5
30°		8.18	0.88	5.17	2.7
40°		9.93	0.94	6.73	3.1
25°	70°	6.91	0.87	3.94	2.3
30°		7.73	0.90	4.67	2.5
40°		9.38	0.95	6.13	2.9
25°	80°	6.44	0.89	3.40	2.1
30°		7.21	0.92	4.07	2.3
40°		8.75	0.98	5.42	2.6

Units are complete packages containing compressor, reversing valve, capillary tube metering device, and heat exchangers. Also included are safety controls: Overload protection for motors, high and low refrigerant pressure switches and a lock-out circuit.

Extended range option includes expansion valve metering device, insulated water coil and solid state lock-out controls.

Performance based on ARI/ISO rated air flow, fluid flow and voltage. For conditions other than rated, consult the FHP EAD selection software. Due to variations in installation actual performance may vary marginally from tabulated values.

As a result of continuing research and development, specifications are subject to change without notice.

FHP MANUFACTURING COMPANY

601 N.W. 65th Court - Fort Lauderdale, FL 33309

Phone: (954) 776-5471 - Fax: (800) 776-5529

<http://www.fhp-mfg.com>



PACKAGED UNITS SPECIFICATION DATA SHEET

FHP MANUFACTURING HIGH-EFFICIENCY WATER SOURCE HEAT PUMPS

EM015

ENERGY-MISER

ELECTRICAL SPECIFICATIONS

Electrical Characteristics	Elect. Symbol	Compressor		Blower		Loop Pump		Min. Circuit Amps	Max. Fuse/Breaker
		RLA	LRA	FLA	HP	FLA	HP		
208/230-1-60	-1	6.8	31.2	1.0	1/10	-	-	9.5	15
265-1-60	-2	5.8	27.0	0.9	1/10	-	-	8.1	15

MECHANICAL SPECIFICATIONS

Refrigerant: R-22			
Air Coil			
Square Feet	Rows Deep	Tube O.D.	Fins/Inch
1.42	3	3/8	14
Water Coil			
Type	Work Press		
Coaxial	450 psig		
Blower Size	Compr Type		
4x7 DD	Reciprocating		
Net Weight	Ship Weight		
158 lbs	170 lbs		

BLOWER PERFORMANCE

Available External Static Pressure (Inches of Water, Gauge. Wet Coil and Filter Included)												
Blower Speed	0.10	0.20	0.30	0.40	0.50	0.60	0.70	0.80	0.90	1.00	1.10	1.20
High	540	515	490	460	430	390	340	-	-	-	-	-
Medium	410	400	390	380	360	330	-	-	-	-	-	-
Low	300	290	280	-	-	-	-	-	-	-	-	-



FLUID PRESSURE DROP

Fluid Flow (GPM)	Pressure Drop	
	(FOH)	(PSIG)
2	3.9	1.7
2.5	5.9	2.5
3	8.2	3.5
4	13.7	5.9
4.5	16.9	7.3

ISO 13256-1 CERTIFIED PERFORMANCE DATA Rated at 500 CFM and 4.0 GPM

Water Loop				Ground Water				Ground Loop (Ext. Range Required)			
Cooling		Heating		Cooling		Heating		Cooling		Heating	
Capacity	EER	Capacity	COP	Capacity	EER	Capacity	COP	Capacity	EER	Capacity	COP
14,500	11.5	20,000	4.2	16,500	16.5	15,000	3.4	14,800	12.7	11,000	2.8

CAPACITY DATA All performance at 500 CFM and 4.0 GPM

COOLING							
EFT Range (Standard) 50°F to 100°F				EFT Range (Ext. Range Option) 45°F to 110°F			
Entering Fluid Temp. (°F)	Entering Air Temp. (°F)	Total Capacity (MBtuH)	Sensible Capacity (MBtuH)	Sensible to Total Ratio	Power Input (kW)	Heat of Reject (MBtuH)	EER
50°	70°db	14.65	9.57	0.65	0.94	17.86	15.6
60°		14.03	9.24	0.66	1.04	17.57	13.5
70°		13.41	8.94	0.67	1.13	17.29	11.8
85°		12.49	8.54	0.68	1.28	16.86	9.7
100°		11.56	8.18	0.71	1.43	16.43	8.1
50°	75°db	15.70	11.43	0.73	0.94	18.92	16.6
60°		15.03	11.04	0.73	1.04	18.59	14.4
70°		14.37	10.69	0.74	1.14	18.27	12.6
85°		13.38	10.21	0.76	1.29	17.78	10.4
100°		12.39	9.78	0.79	1.44	17.29	8.6
50°	80°db	17.23	12.62	0.73	0.95	20.47	18.1
60°		16.50	12.19	0.74	1.05	20.09	15.7
70°		15.77	11.80	0.75	1.15	19.70	13.7
85°		14.69	11.28	0.77	1.30	19.12	11.3
100°		13.60	10.80	0.79	1.45	18.54	9.4
50°	85°db	18.76	13.82	0.74	0.96	22.03	19.6
60°		17.97	13.35	0.74	1.06	21.58	17.0
70°		17.18	12.92	0.75	1.16	21.13	14.8
85°		15.99	12.35	0.77	1.31	20.46	12.2
100°		14.81	11.83	0.80	1.46	19.79	10.2

HEATING					
EFT Range (Standard) 50°F to 80°F			EFT Range (Ext. Range Option) 25°F to 80°F		
Entering Fluid Temp. (°F)	Entering Air Temp. (°F)	Total Capacity (MBtuH)	Power Input (kW)	Heat of Abs. (MBtuH)	COP
50°	60°	16.31	1.29	11.92	3.7
60°		18.86	1.35	14.24	4.1
70°		21.41	1.42	16.56	4.4
80°		23.95	1.49	18.88	4.7
50°		70°	15.42	1.31	10.95
60°	17.83		1.38	13.13	3.8
70°	20.23		1.45	15.30	4.1
80°	22.64		1.51	17.48	4.4
50°	80°		14.37	1.34	9.80
60°		16.61	1.41	11.81	3.5
70°		18.86	1.48	13.82	3.7
80°		21.10	1.55	15.82	4.0

LOW TEMP HEATING					
Extended Range Option Required Antifreeze Required					
Entering Fluid Temp. (°F)	Entering Air Temp. (°F)	Total Capacity (MBtuH)	Power Input (kW)	Heat of Abs. (MBtuH)	COP
25°	60°	9.74	1.12	5.92	2.6
30°		10.99	1.15	7.06	2.8
40°		13.49	1.22	9.33	3.2
25°	70°	9.21	1.14	5.32	2.4
30°		10.39	1.17	6.39	2.6
40°		12.75	1.24	8.52	3.0
25°	80°	8.59	1.16	4.62	2.2
30°		9.69	1.20	5.60	2.4
40°		11.89	1.27	7.56	2.7

Units are complete packages containing compressor, reversing valve, capillary tube metering device, and heat exchangers. Also included are safety controls: Overload protection for motors, high and low refrigerant pressure switches and a lock-out circuit.

Extended range option includes expansion valve metering device, insulated water coil and solid state lock-out controls.

Performance based on ARI/ISO rated air flow, fluid flow and voltage. For conditions other than rated, consult the FHP EAD selection software. Due to variations in installation actual performance may vary marginally from tabulated values.

As a result of continuing research and development, specifications are subject to change without notice.



PACKAGED UNITS SPECIFICATION DATA SHEET

FHP MANUFACTURING HIGH-EFFICIENCY WATER SOURCE HEAT PUMPS

EM018

ENERGY-MISER

ELECTRICAL SPECIFICATIONS

Electrical Characteristics	Elect. Symbol	Compressor		Blower		Loop Pump		Min. Circuit Amps	Max. Fuse/Breaker
		RLA	LRA	FLA	HP	FLA	HP		
208/230-1-60	-1	9.0	48.0	1.8	1/4	-	-	13.1	20
265-1-60	-2	7.7	42.0	1.6	1/4	-	-	11.2	15

MECHANICAL SPECIFICATIONS

Refrigerant: R-22			
Air Coil			
Square Feet	Rows Deep	Tube O.D.	Fins/Inch
1.88	3	3/8	14
Water Coil			
Type	Work Press		
Coaxial	450 psig		
Blower Size	Compr Type		
9x7 DD	Reciprocating		
Net Weight	Ship Weight		
180 lbs	195 lbs		

BLOWER PERFORMANCE

Available External Static Pressure (Inches of Water, Gauge. Wet Coil and Filter Included)												
Blower Speed	0.10	0.20	0.30	0.40	0.50	0.60	0.70	0.80	0.90	1.00	1.10	1.20
High	770	700	680	650	610	570	530	515	-	-	-	-
Medium	670	650	615	570	530	515	-	-	-	-	-	-
Low	560	520	510	-	-	-	-	-	-	-	-	-



FLUID PRESSURE DROP

Fluid Flow (GPM)	Pressure Drop	
	(FOH)	(PSIG)
2.5	5.9	2.5
3	8.2	3.5
4	13.7	5.9
4.5	17.0	7.3
5	20.5	8.9

ISO 13256-1 CERTIFIED PERFORMANCE DATA Rated at 650 CFM and 5.0 GPM

Water Loop				Ground Water				Ground Loop (Ext. Range Required)			
Cooling		Heating		Cooling		Heating		Cooling		Heating	
Capacity	EER	Capacity	COP	Capacity	EER	Capacity	COP	Capacity	EER	Capacity	COP
18,000	12.5	22,000	4.4	21,000	17.0	17,500	3.8	19,000	13.4	13,000	3.2

CAPACITY DATA All performance at 650 CFM and 5.0 GPM

COOLING

EFT Range (Standard) 50°F to 100°F
EFT Range (Ext. Range Option) 45°F to 110°F

Entering Fluid Temp. (°F)	Entering Air Temp. (°F)	Total Capacity (MBtuH)	Sensible Capacity (MBtuH)	Sensible to Total Ratio	Power Input (kW)	Heat of Reject (MBtuH)	EER
50°	70°db 61°wb	18.93	12.39	0.65	1.11	22.73	17.0
60°		18.03	11.90	0.66	1.18	22.07	15.2
70°		17.13	11.45	0.67	1.26	21.42	13.6
85°		15.78	10.82	0.69	1.36	20.43	11.6
100°		14.42	10.23	0.71	1.47	19.45	9.8
50°	75°db 63°wb	20.28	14.80	0.73	1.12	24.10	18.1
60°		19.31	14.21	0.74	1.19	23.38	16.2
70°		18.35	13.67	0.74	1.26	22.66	14.5
85°		16.90	12.92	0.76	1.37	21.58	12.3
100°		15.45	12.22	0.79	1.48	20.51	10.4
50°	80°db 67°wb	22.25	16.32	0.73	1.13	26.10	19.7
60°		21.19	15.68	0.74	1.20	25.29	17.6
70°		20.13	15.08	0.75	1.27	24.48	15.8
85°		18.54	14.26	0.77	1.38	23.27	13.4
100°		16.96	13.49	0.80	1.49	22.05	11.4
50°	85°db 71°wb	24.22	17.87	0.74	1.14	28.10	21.3
60°		23.07	17.16	0.74	1.21	27.20	19.1
70°		21.92	16.51	0.75	1.28	26.30	17.1
85°		20.19	15.61	0.77	1.39	24.95	14.5
100°		18.46	14.77	0.80	1.50	23.60	12.3

Units are complete packages containing compressor, reversing valve, capillary tube metering device, and heat exchangers. Also included are safety controls: Overload protection for motors, high and low refrigerant pressure switches and a lock-out circuit.

Extended range option includes expansion valve metering device, insulated water coil and solid state lock-out controls.

Performance based on ARI/ISO rated air flow, fluid flow and voltage. For conditions other than rated, consult the FHP EAD selection software. Due to variations in installation actual performance may vary marginally from tabulated values.

As a result of continuing research and development, specifications are subject to change without notice.

EM018ip6 mod2 Rev: 5-02

HEATING

EFT Range (Standard) 50°F to 80°F
EFT Range (Ext. Range Option) 25°F to 80°F

Entering Fluid Temp. (°F)	Entering Air Temp. (°F)	Total Capacity (MBtuH)	Power Input (kW)	Heat of Abs. (MBtuH)	COP
50°	60°	18.56	1.30	14.11	4.2
60°		21.10	1.38	16.40	4.5
70°		23.64	1.45	18.68	4.8
80°		26.17	1.53	20.96	5.0
50°		70°	17.54	1.33	13.02
60°	19.94		1.40	15.15	4.2
70°	22.34		1.48	17.29	4.4
80°	24.74		1.56	19.43	4.7
50°	80°		16.35	1.36	11.72
60°		18.58	1.43	13.69	3.8
70°		20.82	1.51	15.65	4.0
80°		23.05	1.59	17.62	4.2

LOW TEMP HEATING

Extended Range Option Required
Antifreeze Required

25°	60°	11.98	1.11	8.17	3.1
30°		13.22	1.15	9.29	3.4
40°		15.71	1.23	11.52	3.7
25°	70°	11.32	1.14	7.45	2.9
30°		12.50	1.17	8.49	3.1
40°		14.85	1.25	10.58	3.5
25°	80°	10.56	1.16	6.60	2.7
30°		11.65	1.20	7.56	2.8
40°		13.84	1.28	9.48	3.2

FHP MANUFACTURING COMPANY

601 N.W. 65th Court - Fort Lauderdale, FL 33309

Phone: (954) 776-5471 - Fax: (800) 776-5529

<http://www.fhp-mfg.com>



PACKAGED UNITS SPECIFICATION DATA SHEET

FHP MANUFACTURING HIGH-EFFICIENCY WATER SOURCE HEAT PUMPS

EM024

ENERGY-MISER

ELECTRICAL SPECIFICATIONS

Electrical Characteristics	Elect. Symbol	Compressor		Blower		Loop Pump		Min. Circuit Amps	Max. Fuse/Breaker
		RLA	LRA	FLA	HP	FLA	HP		
208/230-1-60	-1	9.4	49.0	1.8	1/4	-	-	13.6	20
265-1-60	-2	8.2	44.0	1.6	1/4	-	-	11.9	20

MECHANICAL SPECIFICATIONS

Refrigerant: R-22			
Air Coil			
Square Feet	Rows Deep	Tube O.D.	Fins/Inch
2.12	3	3/8	14
Water Coil			
Type	Work Press		
Coaxial	450 psig		
Blower Size	Compr Type		
9x7 DD	Reciprocating		
Net Weight	Ship Weight		
175 lbs	187 lbs		

BLOWER PERFORMANCE

Available External Static Pressure (Inches of Water, Gauge. Wet Coil and Filter Included)												
Blower Speed	0.10	0.20	0.30	0.40	0.50	0.60	0.70	0.80	0.90	1.00	1.10	1.20
High	920	870	820	780	730	710	700	690	680	670	-	-
Medium	770	740	710	690	670	-	-	-	-	-	-	-
Low	690	670	-	-	-	-	-	-	-	-	-	-



FLUID PRESSURE DROP

Fluid Flow (GPM)	Pressure Drop	
	(FOH)	(PSIG)
3	3.5	1.5
4	5.9	2.6
5	8.9	3.8
6	12.3	5.3
7	16.3	7.0

ISO 13256-1 CERTIFIED PERFORMANCE DATA Rated at 850 CFM and 6.0 GPM

Water Loop				Ground Water				Ground Loop (Ext. Range Required)			
Cooling		Heating		Cooling		Heating		Cooling		Heating	
Capacity	EER	Capacity	COP	Capacity	EER	Capacity	COP	Capacity	EER	Capacity	COP
23000	14.0	29000	4.9	26000	21.0	23000	4.2	24000	15.5	17000	3.5

CAPACITY DATA All performance at 850 CFM and 6.0 GPM

COOLING							
EFT Range (Standard) 50°F to 100°F				EFT Range (Ext. Range Option) 45°F to 110°F			
Entering Fluid Temp. (°F)	Entering Air Temp. (°F)	Total Capacity (MBtuH)	Sensible Capacity (MBtuH)	Sensible to Total Ratio	Power Input (kW)	Heat of Reject (MBtuH)	EER
50°	70°db	23.42	15.52	0.66	1.11	27.23	21.0
60°		22.55	15.06	0.67	1.27	26.87	17.8
70°		21.67	14.66	0.68	1.42	26.51	15.3
85°		20.36	14.13	0.69	1.64	25.97	12.4
100°		19.04	13.68	0.72	1.87	25.42	10.2
50°	75°db	25.09	18.53	0.74	1.12	28.91	22.4
60°		24.15	17.98	0.74	1.27	28.50	18.9
70°		23.21	17.50	0.75	1.42	28.08	16.3
85°		21.81	16.87	0.77	1.65	27.45	13.2
100°		20.40	16.34	0.80	1.88	26.82	10.9
50°	80°db	27.53	20.44	0.74	1.13	31.38	24.4
60°		26.50	19.84	0.75	1.28	30.88	20.7
70°		25.47	19.31	0.76	1.44	30.37	17.7
85°		23.93	18.62	0.78	1.67	29.61	14.4
100°		22.39	18.03	0.81	1.90	28.86	11.8
50°	85°db	29.96	22.38	0.75	1.14	33.85	26.3
60°		28.85	21.72	0.75	1.29	33.26	22.3
70°		27.73	21.14	0.76	1.45	32.67	19.2
85°		26.05	20.38	0.78	1.68	31.78	15.5
100°		24.37	19.74	0.81	1.91	30.89	12.8

HEATING					
EFT Range (Standard) 50°F to 80°F			EFT Range (Ext. Range Option) 25°F to 80°F		
Entering Fluid Temp. (°F)	Entering Air Temp. (°F)	Total Capacity (MBtuH)	Power Input (kW)	Heat of Abs. (MBtuH)	COP
50°	60°	24.39	1.63	18.82	4.4
60°		27.78	1.72	21.92	4.7
70°		31.16	1.80	25.01	5.1
80°		34.55	1.89	28.11	5.4
50°		70°	23.05	1.66	17.38
60°	26.25		1.75	20.29	4.4
70°	29.45		1.83	23.19	4.7
80°	32.65		1.92	26.09	5.0
50°	80°		21.49	1.70	15.69
60°		24.47	1.79	18.36	4.0
70°		27.45	1.88	21.04	4.3
80°		30.42	1.96	23.72	4.5

LOW TEMP HEATING					
Extended Range Option Required Antifreeze Required					
Entering Fluid Temp. (°F)	Entering Air Temp. (°F)	Total Capacity (MBtuH)	Power Input (kW)	Heat of Abs. (MBtuH)	COP
25°	60°	15.61	1.42	10.76	3.2
30°		17.27	1.46	12.28	3.5
40°		20.59	1.55	15.31	3.9
25°	70°	14.76	1.45	9.83	3.0
30°		16.33	1.49	11.25	3.2
40°		19.47	1.58	14.09	3.6
25°	80°	13.76	1.48	8.72	2.7
30°		15.22	1.52	10.03	2.9
40°		18.14	1.61	12.65	3.3

Units are complete packages containing compressor, reversing valve, capillary tube metering device, and heat exchangers. Also included are safety controls: Overload protection for motors, high and low refrigerant pressure switches and a lock-out circuit.

Extended range option includes expansion valve metering device, insulated water coil and solid state lock-out controls.

Performance based on ARI/ISO rated air flow, fluid flow and voltage. For conditions other than rated, consult the FHP EAD selection software. Due to variations in installation actual performance may vary marginally from tabulated values.

As a result of continuing research and development, specifications are subject to change without notice.



PACKAGED UNITS SPECIFICATION DATA SHEET

FHP MANUFACTURING HIGH-EFFICIENCY WATER SOURCE HEAT PUMPS

EM028

ENERGY-MISER

ELECTRICAL SPECIFICATIONS

Electrical Characteristics	Elect. Symbol	Compressor		Blower		Loop Pump		Min. Circuit Amps	Max. Fuse/Breaker
		RLA	LRA	FLA	HP	FLA	HP		
208/230-1-60	-1	12.2	56.0	1.8	1/4	-	-	17.1	25
265-1-60	-2	10.2	55.0	1.6	1/4	-	-	14.4	25
208/230-3-60	-3	8.6	51.0	1.8	1/4	-	-	12.6	20
460-3-60	-4	4.3	25.0	0.9	1/4	-	-	6.3	15

MECHANICAL SPECIFICATIONS

Refrigerant: R-22			
Air Coil			
Square Feet	Rows Deep	Tube O.D.	Fins/Inch
2.29	3	3/8	14
Water Coil			
Type	Work Press		
Coaxial	450 psig		
Blower Size	Compr Type		
9x7 DD	Reciprocating		
Net Weight	Ship Weight		
230 lbs	245 lbs		

BLOWER PERFORMANCE

Available External Static Pressure (Inches of Water, Gauge. Wet Coil and Filter Included)												
Blower Speed	0.10	0.20	0.30	0.40	0.50	0.60	0.70	0.80	0.90	1.00	1.10	1.20
High	1250	1170	1120	1070	940	830	740	650	-	-	-	-
Medium	1050	980	920	830	760	700	-	-	-	-	-	-
Low	975	910	870	740	640	-	-	-	-	-	-	-



FLUID PRESSURE DROP

Fluid Flow (GPM)	Pressure Drop	
	(FOH)	(PSIG)
3.5	3.9	1.7
5	7.4	3.2
6	10.3	4.5
7	13.6	5.9
9	21.4	9.3

ISO 13256-1 CERTIFIED PERFORMANCE DATA Rated at 950 CFM and 7.0 GPM

Water Loop				Ground Water				Ground Loop (Ext. Range Required)			
Cooling		Heating		Cooling		Heating		Cooling		Heating	
Capacity	EER	Capacity	COP	Capacity	EER	Capacity	COP	Capacity	EER	Capacity	COP
28,000	13.1	32,000	4.7	32,000	18.9	26,000	4.0	29,500	14.6	19,000	3.3

CAPACITY DATA All performance at 950 CFM and 7.0 GPM

COOLING

EFT Range (Standard) 50°F to 100°F
EFT Range (Ext. Range Option) 45°F to 110°F

Entering Fluid Temp. (°F)	Entering Air Temp. (°F)	Total Capacity (MBtuH)	Sensible Capacity (MBtuH)	Sensible to Total Ratio	Power Input (kW)	Heat of Reject (MBtuH)	EER
50°	70°db 61°wb	28.72	18.78	0.65	1.48	33.76	19.4
60°		27.56	18.17	0.66	1.63	33.11	16.9
70°		26.40	17.62	0.67	1.77	32.45	14.9
85°		24.66	16.89	0.69	2.00	31.47	12.4
100°		22.92	16.25	0.71	2.22	30.49	10.3
50°	75°db 63°wb	30.76	22.43	0.73	1.49	35.83	20.7
60°		29.52	21.70	0.74	1.64	35.10	18.1
70°		28.28	21.05	0.74	1.78	34.37	15.9
85°		26.42	20.18	0.76	2.01	33.27	13.2
100°		24.55	19.41	0.79	2.23	32.17	11.0
50°	80°db 67°wb	33.75	24.75	0.73	1.50	38.86	22.5
60°		32.39	23.95	0.74	1.65	38.02	19.7
70°		31.03	23.23	0.75	1.80	37.17	17.3
85°		28.99	22.27	0.77	2.02	35.89	14.3
100°		26.95	21.43	0.80	2.25	34.62	12.0
50°	85°db 71°wb	36.74	27.09	0.74	1.51	41.90	24.3
60°		35.26	26.22	0.74	1.66	40.93	21.2
70°		33.78	25.43	0.75	1.81	39.97	18.6
85°		31.56	24.39	0.77	2.04	38.52	15.5
100°		29.34	23.46	0.80	2.27	37.08	12.9

HEATING

EFT Range (Standard) 50°F to 80°F
EFT Range (Ext. Range Option) 25°F to 80°F

Entering Fluid Temp. (°F)	Entering Air Temp. (°F)	Total Capacity (MBtuH)	Power Input (kW)	Heat of Abs. (MBtuH)	COP
50°	60°	27.31	1.89	20.85	4.2
60°		30.97	1.98	24.23	4.6
70°		34.64	2.06	27.61	4.9
80°		38.31	2.15	30.99	5.2
50°		70°	25.81	1.93	19.24
60°	29.28		2.01	22.41	4.3
70°	32.75		2.10	25.59	4.6
80°	36.21		2.18	28.76	4.9
50°	80°		24.06	1.97	17.35
60°		27.29	2.06	20.27	3.9
70°		30.52	2.14	23.20	4.2
80°		33.75	2.23	26.13	4.4

LOW TEMP HEATING

Extended Range Option Required
Antifreeze Required

25°	60°	17.78	1.68	12.05	3.1
30°		19.58	1.72	13.70	3.3
40°		23.17	1.81	17.01	3.8
25°	70°	16.81	1.71	10.98	2.9
30°		18.51	1.75	12.53	3.1
40°		21.91	1.84	15.63	3.5
25°	80°	15.68	1.75	9.71	2.6
30°		17.26	1.79	11.15	2.8
40°		20.43	1.88	14.01	3.2

Units are complete packages containing compressor, reversing valve, capillary tube metering device, and heat exchangers. Also included are safety controls: Overload protection for motors, high and low refrigerant pressure switches and a lock-out circuit.

Extended range option includes expansion valve metering device, insulated water coil and solid state lock-out controls.

Performance based on ARI/ISO rated air flow, fluid flow and voltage. For conditions other than rated, consult the FHP EAD selection software. Due to variations in installation actual performance may vary marginally from tabulated values.

As a result of continuing research and development, specifications are subject to change without notice.

FHP MANUFACTURING COMPANY

601 N.W. 65th Court - Fort Lauderdale, FL 33309

Phone: (954) 776-5471 - Fax: (800) 776-5529

<http://www.fhp-mfg.com>



PACKAGED UNITS SPECIFICATION DATA SHEET

FHP MANUFACTURING HIGH-EFFICIENCY WATER SOURCE HEAT PUMPS

EM031

ENERGY-MISER

ELECTRICAL SPECIFICATIONS

Electrical Characteristics	Elect. Symbol	Compressor		Blower		Loop Pump		Min. Circuit Amps	Max. Fuse/Breaker
		RLA	LRA	FLA	HP	FLA	HP		
208/230-1-60	-1	14.7	81.0	1.8	1/4	-	-	20.2	35
265-1-60	-2	12.8	72.0	1.6	1/4	-	-	17.6	30
208/230-3-60	-3	10.7	70.0	1.8	1/4	-	-	15.2	25
460-3-60	-4	5.1	36.0	0.9	1/4	-	-	7.3	15

MECHANICAL SPECIFICATIONS

Refrigerant: R-22			
Air Coil			
Square Feet	Rows Deep	Tube O.D.	Fins/Inch
2.29	3	3/8	14
Water Coil			
Type	Work Press		
Coaxial	450 psig		
Blower Size	Compr Type		
9x7 DD	Reciprocating		
Net Weight	Ship Weight		
233 lbs	248 lbs		

BLOWER PERFORMANCE

Available External Static Pressure (Inches of Water, Gauge. Wet Coil and Filter Included)												
Blower Speed	0.10	0.20	0.30	0.40	0.50	0.60	0.70	0.80	0.90	1.00	1.10	1.20
High	1250	1170	1120	1070	940	830	740	650	-	-	-	-
Medium	1050	980	920	830	760	700	-	-	-	-	-	-
Low	975	910	870	740	640	-	-	-	-	-	-	-



FLUID PRESSURE DROP

Fluid Flow (GPM)	Pressure Drop	
	(FOH)	(PSIG)
4	2.1	0.9
5	3.2	1.4
7.5	6.5	2.8
9	9.1	3.9
11	13.0	5.6

ISO 13256-1 CERTIFIED PERFORMANCE DATA Rated at 1,000 CFM and 7.5 GPM

Water Loop				Ground Water				Ground Loop (Ext. Range Required)			
Cooling		Heating		Cooling		Heating		Cooling		Heating	
Capacity	EER	Capacity	COP	Capacity	EER	Capacity	COP	Capacity	EER	Capacity	COP
32,000	13.3	40,000	4.7	37,000	19.1	31,500	3.7	34,500	14.7	23,500	3.0



CAPACITY DATA All performance at 1,000 CFM and 7.5 GPM

COOLING							
EFT Range (Standard) 50°F to 100°F				EFT Range (Ext. Range Option) 45°F to 110°F			
Entering Fluid Temp. (°F)	Entering Air Temp. (°F)	Total Capacity (MBtuH)	Sensible Capacity (MBtuH)	Sensible to Total Ratio	Power Input (kW)	Heat of Reject (MBtuH)	EER
50°	70°db 61°wb	33.14	21.43	0.65	1.74	39.09	19.0
60°		31.65	20.64	0.65	1.91	38.16	16.6
70°		30.17	19.92	0.66	2.07	37.23	14.6
85°		27.94	18.93	0.68	2.32	35.84	12.1
100°		25.71	18.02	0.70	2.56	34.45	10.0
50°	75°db 63°wb	35.49	25.58	0.72	1.75	41.47	20.3
60°		33.90	24.64	0.73	1.92	40.44	17.7
70°		32.31	23.78	0.74	2.08	39.41	15.5
85°		29.92	22.60	0.76	2.33	37.87	12.8
100°		27.54	21.52	0.78	2.58	36.33	10.7
50°	80°db 67°wb	38.93	28.22	0.72	1.77	44.96	22.0
60°		37.19	27.18	0.73	1.93	43.78	19.2
70°		35.45	26.23	0.74	2.10	42.61	16.9
85°		32.83	24.93	0.76	2.35	40.84	14.0
100°		30.21	23.75	0.79	2.60	39.08	11.6
50°	85°db 71°wb	42.37	30.89	0.73	1.78	48.45	23.8
60°		40.48	29.75	0.74	1.95	47.13	20.8
70°		38.58	28.71	0.74	2.12	45.80	18.2
85°		35.74	27.29	0.76	2.37	43.81	15.1
100°		32.89	25.99	0.79	2.62	41.82	12.6

HEATING

HEATING					
EFT Range (Standard) 50°F to 80°F			EFT Range (Ext. Range Option) 25°F to 80°F		
Entering Fluid Temp. (°F)	Entering Air Temp. (°F)	Total Capacity (MBtuH)	Power Input (kW)	Heat of Abs. (MBtuH)	COP
50°	60°	33.52	2.44	25.20	4.0
60°		38.17	2.49	29.66	4.5
70°		42.83	2.55	34.13	4.9
80°		47.48	2.60	38.60	5.3
50°		70°	31.68	2.48	23.21
60°	36.08		2.54	27.41	4.2
70°	40.47		2.59	31.62	4.6
80°	44.87		2.65	35.82	5.0
50°	80°		29.53	2.54	20.86
60°		33.62	2.60	24.76	3.8
70°		37.71	2.65	28.66	4.2
80°		41.81	2.71	32.56	4.5

LOW TEMP HEATING

LOW TEMP HEATING					
Extended Range Option Required Antifreeze Required					
Entering Fluid Temp. (°F)	Entering Air Temp. (°F)	Total Capacity (MBtuH)	Power Input (kW)	Heat of Abs. (MBtuH)	COP
25°	60°	21.46	2.30	13.60	2.7
30°		23.74	2.33	15.79	3.0
40°		28.30	2.38	20.16	3.5
25°	70°	20.29	2.35	12.28	2.5
30°		22.45	2.37	14.34	2.8
40°		26.75	2.43	18.46	3.2
25°	80°	18.92	2.40	10.73	2.3
30°		20.92	2.43	12.64	2.5
40°		24.93	2.48	16.46	2.9

Units are complete packages containing compressor, reversing valve, capillary tube metering device, and heat exchangers. Also included are safety controls: Overload protection for motors, high and low refrigerant pressure switches and a lock-out circuit.

Extended range option includes expansion valve metering device, insulated water coil and solid state lock-out controls.

Performance based on ARI/ISO rated air flow, fluid flow and voltage. For conditions other than rated, consult the FHP EAD selection software. Due to variations in installation actual performance may vary marginally from tabulated values.

As a result of continuing research and development, specifications are subject to change without notice.



PACKAGED UNITS SPECIFICATION DATA SHEET

FHP MANUFACTURING HIGH-EFFICIENCY WATER SOURCE HEAT PUMPS

EM036

ENERGY-MISER

ELECTRICAL SPECIFICATIONS

Electrical Characteristics	Elect. Symbol	Compressor		Blower		Loop Pump		Min. Circuit Amps	Max. Fuse/Breaker
		RLA	LRA	FLA	HP	FLA	HP		
208/230-1-60	-1	14.7	81.0	3.9	1/2	-	-	22.3	35
265-1-60	-2	12.8	72.0	2.3	1/2	-	-	18.3	30
208/230-3-60	-3	10.7	70.0	3.9	1/2	-	-	16.5	25
460-3-60	-4	5.1	36.0	2.0	1/2	-	-	8.3	15

MECHANICAL SPECIFICATIONS

Refrigerant: R-22			
Air Coil			
Square Feet	Rows Deep	Tube O.D.	Fins/Inch
3.50	3	3/8	14
Water Coil			
Type	Work Press		
Coaxial	450 psig		
Blower Size	Compr Type		
9x7 DD	Reciprocating		
Net Weight	Ship Weight		
253 lbs	273 lbs		

BLOWER PERFORMANCE

Available External Static Pressure (Inches of Water, Gauge. Wet Coil and Filter Included)												
Blower Speed	0.10	0.20	0.30	0.40	0.50	0.60	0.70	0.80	0.90	1.00	1.10	1.20
High	1500	1440	1370	1290	1210	1120	1000	900	-	-	-	-
Medium	1410	1350	1290	1220	1150	1060	900	-	-	-	-	-
Low	1290	1250	1200	1150	1080	1000	-	-	-	-	-	-



FLUID PRESSURE DROP

Fluid Flow (GPM)	Pressure Drop	
	(FOH)	(PSIG)
4	2.1	0.9
5	3.2	1.4
7.5	6.5	2.8
9	9.1	3.9
11	13.0	5.6

ISO 13256-1 CERTIFIED PERFORMANCE DATA Rated at 1,200 CFM and 9.0 GPM

Water Loop				Ground Water				Ground Loop (Ext. Range Required)			
Cooling		Heating		Cooling		Heating		Cooling		Heating	
Capacity	EER	Capacity	COP	Capacity	EER	Capacity	COP	Capacity	EER	Capacity	COP
34,000	14.0	40,000	4.7	38,000	20.1	31,500	4.0	35,000	15.3	23,500	3.4



CAPACITY DATA All performance at 1,200 CFM and 9.0 GPM

COOLING							
EFT Range (Standard) 50°F to 100°F				EFT Range (Ext. Range Option) 45°F to 110°F			
Entering Fluid Temp. (°F)	Entering Air Temp. (°F)	Total Capacity (MBtuH)	Sensible Capacity (MBtuH)	Sensible to Total Ratio	Power Input (kW)	Heat of Reject (MBtuH)	EER
50°	70°db 61°wb	34.18	21.85	0.64	1.88	40.59	18.2
60°		32.90	21.21	0.64	2.08	39.99	15.8
70°		31.62	20.63	0.65	2.28	39.39	13.9
85°		29.70	19.89	0.67	2.57	38.49	11.5
100°		27.78	19.26	0.69	2.87	37.59	9.7
50°	75°db 63°wb	36.64	26.17	0.71	1.89	43.09	19.4
60°		35.27	25.40	0.72	2.09	42.40	16.9
70°		33.90	24.72	0.73	2.29	41.71	14.8
85°		31.84	23.83	0.75	2.59	40.68	12.3
100°		29.78	23.08	0.77	2.89	39.65	10.3
50°	80°db 67°wb	40.24	28.91	0.72	1.90	46.73	21.2
60°		38.74	28.07	0.72	2.10	45.92	18.4
70°		37.23	27.31	0.73	2.31	45.10	16.1
85°		34.98	26.34	0.75	2.61	43.88	13.4
100°		32.72	25.51	0.78	2.91	42.66	11.2
50°	85°db 71°wb	43.84	31.69	0.72	1.92	50.38	22.9
60°		42.20	30.76	0.73	2.12	49.44	19.9
70°		40.56	29.94	0.74	2.32	48.49	17.5
85°		38.11	28.87	0.76	2.63	47.08	14.5
100°		35.66	27.96	0.78	2.93	45.67	12.2

HEATING

HEATING					
EFT Range (Standard) 50°F to 80°F			EFT Range (Ext. Range Option) 25°F to 80°F		
Entering Fluid Temp. (°F)	Entering Air Temp. (°F)	Total Capacity (MBtuH)	Power Input (kW)	Heat of Abs. (MBtuH)	COP
50°	60°	34.54	2.41	26.30	4.2
60°		39.27	2.54	30.59	4.5
70°		44.00	2.67	34.88	4.8
80°		48.72	2.80	39.17	5.1
50°		70°	32.67	2.46	24.29
60°	37.14		2.59	28.31	4.2
70°	41.61		2.72	32.33	4.5
80°	46.07		2.85	36.34	4.7
50°	80°		30.48	2.51	21.92
60°		34.64	2.64	25.62	3.8
70°		38.80	2.78	29.32	4.1
80°		42.96	2.91	33.02	4.3

LOW TEMP HEATING

LOW TEMP HEATING					
Extended Range Option Required Antifreeze Required					
Entering Fluid Temp. (°F)	Entering Air Temp. (°F)	Total Capacity (MBtuH)	Power Input (kW)	Heat of Abs. (MBtuH)	COP
25°	60°	22.28	2.09	15.14	3.1
30°		24.60	2.16	17.24	3.3
40°		29.23	2.29	21.43	3.7
25°	70°	21.09	2.13	13.82	2.9
30°		23.28	2.19	15.79	3.1
40°		27.66	2.33	19.72	3.5
25°	80°	19.69	2.17	12.27	2.7
30°		21.73	2.24	14.08	2.8
40°		25.80	2.37	17.70	3.2

Units are complete packages containing compressor, reversing valve, capillary tube metering device, and heat exchangers. Also included are safety controls: Overload protection for motors, high and low refrigerant pressure switches and a lock-out circuit.

Extended range option includes expansion valve metering device, insulated water coil and solid state lock-out controls.

Performance based on ARI/ISO rated air flow, fluid flow and voltage. For conditions other than rated, consult the FHP EAD selection software. Due to variations in installation actual performance may vary marginally from tabulated values.

As a result of continuing research and development, specifications are subject to change without notice.



PACKAGED UNITS SPECIFICATION DATA SHEET

FHP MANUFACTURING HIGH-EFFICIENCY WATER SOURCE HEAT PUMPS

EM041

ENERGY-MISER

ELECTRICAL SPECIFICATIONS

Electrical Characteristics	Elect. Symbol	Compressor		Blower		Loop Pump		Min. Circuit Amps	Max. Fuse/Breaker
		RLA	LRA	FLA	HP	FLA	HP		
208/230-1-60	-1	18.9	96.0	3.9	1/2	-	-	27.5	45
208/230-3-60	-3	12.2	75.0	3.9	1/2	-	-	19.2	30
460-3-60	-4	6.2	40.0	2.0	1/2	-	-	9.8	15
575-3-60	-5	4.9	31.0	2.6	3/4	-	-	8.7	15

MECHANICAL SPECIFICATIONS

Refrigerant: R-22			
Air Coil			
Square Feet	Rows Deep	Tube O.D.	Fins/Inch
2.29	4	3/8	14
Water Coil			
Type	Work Press		
Coaxial	450 psig		
Blower Size	Compr Type		
9x7 DD	Reciprocating		
Net Weight	Ship Weight		
250 lbs	265 lbs		

BLOWER PERFORMANCE

Available External Static Pressure (Inches of Water, Gauge. Wet Coil and Filter Included)												
Blower Speed	0.10	0.20	0.30	0.40	0.50	0.60	0.70	0.80	0.90	1.00	1.10	1.20
High	1260	1180	1100	1030	960	870	810	620	-	-	-	-
Medium	1210	1150	1070	1010	940	850	750	-	-	-	-	-
Low	1160	1100	1040	980	910	830	-	-	-	-	-	-



FLUID PRESSURE DROP

Fluid Flow (GPM)	Pressure Drop	
	(FOH)	(PSIG)
5	3.2	1.4
7	5.8	2.5
9	9.1	3.9
11	13.0	5.6
13	17.6	7.6

ISO 13256-1 CERTIFIED PERFORMANCE DATA Rated at 1,150 CFM and 9.0 GPM

Water Loop				Ground Water				Ground Loop (Ext. Range Required)			
Cooling		Heating		Cooling		Heating		Cooling		Heating	
Capacity	EER	Capacity	COP	Capacity	EER	Capacity	COP	Capacity	EER	Capacity	COP
38,500	12.5	49,000	4.3	41,000	16.1	39,000	3.8	39,000	13.3	28,000	3.2

CAPACITY DATA All performance at 1,150 CFM and 9.0 GPM

COOLING

EFT Range (Standard) 50°F to 100°F
EFT Range (Ext. Range Option) 45°F to 110°F

Entering Fluid Temp. (°F)	Entering Air Temp. (°F)	Total Capacity (MBtuH)	Sensible Capacity (MBtuH)	Sensible to Total Ratio	Power Input (kW)	Heat of Reject (MBtuH)	EER
50°	70°db 61°wb	36.08	23.33	0.65	2.31	43.95	15.6
60°		35.36	23.06	0.65	2.49	43.85	14.2
70°		34.64	22.87	0.66	2.67	43.75	13.0
85°		33.55	22.74	0.68	2.94	43.60	11.4
100°		32.47	22.77	0.70	3.22	43.45	10.1
50°	75°db 63°wb	38.64	27.85	0.72	2.32	46.56	16.7
60°		37.87	27.52	0.73	2.50	46.41	15.1
70°		37.10	27.30	0.74	2.69	46.26	13.8
85°		35.94	27.15	0.76	2.96	46.05	12.1
100°		34.78	27.19	0.78	3.24	45.83	10.7
50°	80°db 67°wb	42.39	30.72	0.72	2.34	50.37	18.1
60°		41.54	30.36	0.73	2.52	50.15	16.5
70°		40.70	30.12	0.74	2.71	49.94	15.0
85°		39.43	29.95	0.76	2.99	49.62	13.2
100°		38.16	30.00	0.79	3.26	49.29	11.7
50°	85°db 71°wb	46.14	33.63	0.73	2.36	54.18	19.6
60°		45.22	33.23	0.73	2.54	53.90	17.8
70°		44.30	32.97	0.74	2.73	53.61	16.2
85°		42.92	32.78	0.76	3.01	53.19	14.3
100°		41.53	32.83	0.79	3.29	52.76	12.6

Units are complete packages containing compressor, reversing valve, capillary tube metering device, and heat exchangers. Also included are safety controls: Overload protection for motors, high and low refrigerant pressure switches and a lock-out circuit.

Extended range option includes expansion valve metering device, insulated water coil and solid state lock-out controls.

Performance based on ARI/ISO rated air flow, fluid flow and voltage. For conditions other than rated, consult the FHP EAD selection software. Due to variations in installation actual performance may vary marginally from tabulated values.

As a result of continuing research and development, specifications are subject to change without notice.

EM041ip6 mod2 Rev: 5-02

HEATING

EFT Range (Standard) 50°F to 80°F
EFT Range (Ext. Range Option) 25°F to 80°F

Entering Fluid Temp. (°F)	Entering Air Temp. (°F)	Total Capacity (MBtuH)	Power Input (kW)	Heat of Abs. (MBtuH)	COP
50°	60°	40.94	2.96	30.82	4.0
60°		46.87	3.17	36.04	4.3
70°		52.81	3.39	41.25	4.6
80°		58.75	3.60	46.47	4.8
50°		70°	38.69	3.02	28.39
60°	44.30		3.23	33.26	4.0
70°	49.91		3.45	38.14	4.2
80°	55.52		3.67	43.01	4.4
50°	80°		36.05	3.09	25.52
60°		41.28	3.31	29.99	3.7
70°		46.50	3.53	34.46	3.9
80°		51.73	3.75	38.93	4.0

LOW TEMP HEATING

Extended Range Option Required
Antifreeze Required

25°	60°	25.58	2.43	17.27	3.1
30°		28.49	2.54	19.82	3.3
40°		34.31	2.75	24.92	3.7
25°	70°	24.18	2.48	15.72	2.9
30°		26.93	2.59	18.11	3.1
40°		32.43	2.80	22.87	3.4
25°	80°	22.54	2.53	13.89	2.6
30°		25.10	2.64	16.08	2.8
40°		30.23	2.87	20.45	3.1

FHP MANUFACTURING COMPANY

601 N.W. 65th Court - Fort Lauderdale, FL 33309

Phone: (954) 776-5471 - Fax: (800) 776-5529

<http://www.fhp-mfg.com>



PACKAGED UNITS SPECIFICATION DATA SHEET

FHP MANUFACTURING HIGH-EFFICIENCY WATER SOURCE HEAT PUMPS

EM042

ENERGY-MISER

ELECTRICAL SPECIFICATIONS

Electrical Characteristics	Elect. Symbol	Compressor		Blower		Loop Pump		Min. Circuit Amps	Max. Fuse/Breaker
		RLA	LRA	FLA	HP	FLA	HP		
208/230-1-60	-1	17.1	96.0	3.9	1/2	-	-	25.3	40
208/230-3-60	-3	11.1	75.0	3.9	1/2	-	-	17.8	25
460-3-60	-4	5.6	40.0	2.0	1/2	-	-	9.0	15
575-3-60	-5	4.4	31.0	2.6	3/4	-	-	8.1	15

MECHANICAL SPECIFICATIONS

Refrigerant: R-22			
Air Coil			
Square Feet	Rows Deep	Tube O.D.	Fins/Inch
3.50	3	3/8	14
Water Coil			
Type	Work Press		
Coaxial	450 psig		
Blower Size	Compr Type		
9x7 DD	Reciprocating		
Net Weight	Ship Weight		
256 lbs	276 lbs		

BLOWER PERFORMANCE

Available External Static Pressure (Inches of Water, Gauge. Wet Coil and Filter Included)												
Blower Speed	0.10	0.20	0.30	0.40	0.50	0.60	0.70	0.80	0.90	1.00	1.10	1.20
High	1560	1500	1420	1340	1260	1170	1070	950	-	-	-	-
Medium	1470	1410	1340	1270	1200	1110	1010	-	-	-	-	-
Low	1340	1300	1250	1200	1130	1050	-	-	-	-	-	-



FLUID PRESSURE DROP

Fluid Flow (GPM)	Pressure Drop	
	(FOH)	(PSIG)
5	3.2	1.4
7	5.8	2.5
10	11.0	4.8
11	13.0	5.6
13	17.6	7.6

ISO 13256-1 CERTIFIED PERFORMANCE DATA Rated at 1,500 CFM and 10.0 GPM

Water Loop				Ground Water				Ground Loop (Ext. Range Required)			
Cooling		Heating		Cooling		Heating		Cooling		Heating	
Capacity	EER	Capacity	COP	Capacity	EER	Capacity	COP	Capacity	EER	Capacity	COP
41,500	12.8	50,500	4.3	44,000	16.9	40,000	3.9	42,500	13.6	30,000	3.2



CAPACITY DATA All performance at 1,500 CFM and 10.0 GPM

COOLING

EFT Range (Standard) 50°F to 100°F
EFT Range (Ext. Range Option) 45°F to 110°F

Entering Fluid Temp. (°F)	Entering Air Temp. (°F)	Total Capacity (MBtuH)	Sensible Capacity (MBtuH)	Sensible to Total Ratio	Power Input (kW)	Heat of Reject (MBtuH)	EER
50°	70°db	38.24	25.01	0.65	2.40	46.41	16.0
60°		37.51	24.74	0.66	2.63	46.50	14.2
70°		36.78	24.57	0.67	2.87	46.58	12.8
85°		35.70	24.47	0.69	3.23	46.71	11.1
100°		34.61	24.55	0.71	3.58	46.84	9.7
50°	75°db	40.96	29.87	0.73	2.41	49.18	17.0
60°		40.18	29.55	0.74	2.65	49.22	15.2
70°		39.40	29.34	0.74	2.89	49.26	13.6
85°		38.24	29.23	0.76	3.25	49.32	11.8
100°		37.07	29.33	0.79	3.60	49.37	10.3
50°	80°db	44.94	32.96	0.73	2.43	53.22	18.5
60°		44.09	32.60	0.74	2.67	53.20	16.5
70°		43.23	32.38	0.75	2.91	53.17	14.9
85°		41.96	32.25	0.77	3.27	53.12	12.8
100°		40.68	32.36	0.80	3.63	53.08	11.2
50°	85°db	48.92	36.08	0.74	2.45	57.27	20.0
60°		47.99	35.69	0.74	2.69	57.17	17.8
70°		47.07	35.44	0.75	2.93	57.08	16.0
85°		45.68	35.31	0.77	3.30	56.93	13.8
100°		44.29	35.43	0.80	3.66	56.79	12.1

HEATING

EFT Range (Standard) 50°F to 80°F
EFT Range (Ext. Range Option) 25°F to 80°F

Entering Fluid Temp. (°F)	Entering Air Temp. (°F)	Total Capacity (MBtuH)	Power Input (kW)	Heat of Abs. (MBtuH)	COP
50°	60°	42.61	3.07	32.14	4.1
60°		48.39	3.26	37.27	4.4
70°		54.17	3.45	42.40	4.6
80°		59.96	3.64	47.53	4.8
50°		70°	40.28	3.13	29.61
60°	45.74		3.32	34.41	4.0
70°	51.20		3.51	39.21	4.3
80°	56.67		3.71	44.01	4.5
50°	80°		37.54	3.20	26.63
60°		42.63	3.39	31.04	3.7
70°		47.71	3.59	35.45	3.9
80°		52.80	3.79	39.86	4.1

LOW TEMP HEATING

Extended Range Option Required
Antifreeze Required

25°	60°	27.61	2.59	18.75	3.1
30°		30.44	2.69	21.26	3.3
40°		36.11	2.88	26.28	3.7
25°	70°	26.10	2.64	17.09	2.9
30°		28.78	2.74	19.44	3.1
40°		34.14	2.93	24.13	3.4
25°	80°	24.34	2.70	15.12	2.6
30°		26.83	2.80	17.28	2.8
40°		31.82	3.00	21.59	3.1

Units are complete packages containing compressor, reversing valve, capillary tube metering device, and heat exchangers. Also included are safety controls: Overload protection for motors, high and low refrigerant pressure switches and a lock-out circuit.

Extended range option includes expansion valve metering device, insulated water coil and solid state lock-out controls.

Performance based on ARI/ISO rated air flow, fluid flow and voltage. For conditions other than rated, consult the FHP EAD selection software. Due to variations in installation actual performance may vary marginally from tabulated values.

As a result of continuing research and development, specifications are subject to change without notice.

FHP MANUFACTURING COMPANY

601 N.W. 65th Court - Fort Lauderdale, FL 33309

Phone: (954) 776-5471 - Fax: (800) 776-5529

<http://www.fhp-mfg.com>



PACKAGED UNITS SPECIFICATION DATA SHEET

FHP MANUFACTURING HIGH-EFFICIENCY WATER SOURCE HEAT PUMPS

EM048

ENERGY-MISER

ELECTRICAL SPECIFICATIONS

Electrical Characteristics	Elect. Symbol	Compressor		Blower		Loop Pump		Min. Circuit Amps	Max. Fuse/Breaker
		RLA	LRA	FLA	HP	FLA	HP		
208/230-1-60	-1	19.3	102.0	5.2	3/4	-	-	29.3	45
208/230-3-60	-3	12.9	91.0	5.2	3/4	-	-	21.3	30
460-3-60	-4	6.4	42.0	2.5	3/4	-	-	10.5	15
575-3-60	-5	5.2	39.0	2.6	3/4	-	-	9.1	15

MECHANICAL SPECIFICATIONS

Refrigerant: R-22			
Air Coil			
Square Feet	Rows Deep	Tube O.D.	Fins/Inch
4.50	3	3/8	14
Water Coil			
Type	Work Press		
Coaxial	450 psig		
Blower Size	Compr Type		
10x8 DD	Reciprocating		
Net Weight	Ship Weight		
290 lbs	314 lbs		

BLOWER PERFORMANCE

Available External Static Pressure (Inches of Water, Gauge. Wet Coil and Filter Included)												
Blower Speed	0.10	0.20	0.30	0.40	0.50	0.60	0.70	0.80	0.90	1.00	1.10	1.20
High	1980	1960	1930	1840	1800	1730	1680	1610	1500	-	-	-
Medium	1940	1910	1850	1770	1740	1690	1660	1530	-	-	-	-
Low	1900	1870	1810	1730	1710	1600	-	-	-	-	-	-



FLUID PRESSURE DROP

Fluid Flow (GPM)	Pressure Drop	
	(FOH)	(PSIG)
6	2.9	1.3
9	6.1	2.6
12	10.2	4.4
14	13.5	5.9
16	17.2	7.4

ISO 13256-1 CERTIFIED PERFORMANCE DATA Rated at 1,600 CFM and 12.0 GPM

Water Loop				Ground Water				Ground Loop (Ext. Range Required)			
Cooling		Heating		Cooling		Heating		Cooling		Heating	
Capacity	EER	Capacity	COP	Capacity	EER	Capacity	COP	Capacity	EER	Capacity	COP
48,000	12.2	61,000	4.6	58,000	18.0	49,000	4.0	51,000	13.4	38,000	3.4



CAPACITY DATA All performance at 1,600 CFM and 12.0 GPM

COOLING

EFT Range (Standard) 50°F to 100°F
EFT Range (Ext. Range Option) 45°F to 110°F

Entering Fluid Temp. (°F)	Entering Air Temp. (°F)	Total Capacity (MBtuH)	Sensible Capacity (MBtuH)	Sensible to Total Ratio	Power Input (kW)	Heat of Reject (MBtuH)	EER
50°	70°db	51.91	33.70	0.65	3.26	63.05	15.9
60°		48.86	31.97	0.65	3.53	60.92	13.8
70°		45.81	30.34	0.66	3.80	58.79	12.1
85°		41.24	28.02	0.68	4.20	55.59	9.8
100°		36.66	25.77	0.70	4.61	52.39	8.0
50°	75°db	55.66	40.39	0.73	3.28	66.85	17.0
60°		52.39	38.33	0.73	3.55	64.51	14.8
70°		49.13	36.39	0.74	3.82	62.17	12.9
85°		44.23	33.62	0.76	4.23	58.66	10.5
100°		39.34	30.94	0.79	4.63	55.15	8.5
50°	80°db	61.14	44.64	0.73	3.30	72.41	18.5
60°		57.56	42.37	0.74	3.58	69.77	16.1
70°		53.98	40.23	0.75	3.85	67.12	14.0
85°		48.61	37.18	0.76	4.26	63.15	11.4
100°		43.25	34.23	0.79	4.67	59.18	9.3
50°	85°db	66.62	48.94	0.73	3.33	77.98	20.0
60°		62.73	46.46	0.74	3.60	75.03	17.4
70°		58.83	44.12	0.75	3.88	72.07	15.2
85°		53.00	40.78	0.77	4.29	67.64	12.3
100°		47.16	37.55	0.80	4.71	63.22	10.0

HEATING

EFT Range (Standard) 50°F to 80°F
EFT Range (Ext. Range Option) 25°F to 80°F

Entering Fluid Temp. (°F)	Entering Air Temp. (°F)	Total Capacity (MBtuH)	Power Input (kW)	Heat of Abs. (MBtuH)	COP
50°	60°	53.13	3.83	40.06	4.1
60°		59.59	4.00	45.95	4.4
70°		66.05	4.16	51.84	4.6
80°		72.51	4.33	57.73	4.9
50°		70°	50.27	3.90	36.97
60°	56.37		4.07	42.49	4.1
70°	62.48		4.24	48.02	4.3
80°	68.58		4.41	53.54	4.6
50°	80°		46.90	3.98	33.33
60°		52.59	4.15	38.42	3.7
70°		58.27	4.33	43.51	3.9
80°		63.96	4.50	48.59	4.2

LOW TEMP HEATING

Extended Range Option Required
Antifreeze Required

25°	60°	36.26	3.41	24.61	3.1
30°		39.42	3.50	27.49	3.3
40°		45.76	3.66	33.26	3.7
25°	70°	34.32	3.47	22.48	2.9
30°		37.32	3.56	25.18	3.1
40°		43.30	3.73	30.58	3.4
25°	80°	32.05	3.54	19.96	2.7
30°		34.84	3.63	22.45	2.8
40°		40.41	3.80	27.43	3.1

Units are complete packages containing compressor, reversing valve, capillary tube metering device, and heat exchangers. Also included are safety controls: Overload protection for motors, high and low refrigerant pressure switches and a lock-out circuit.

Extended range option includes expansion valve metering device, insulated water coil and solid state lock-out controls.

Performance based on ARI/ISO rated air flow, fluid flow and voltage. For conditions other than rated, consult the FHP EAD selection software. Due to variations in installation actual performance may vary marginally from tabulated values.

As a result of continuing research and development, specifications are subject to change without notice.

FHP MANUFACTURING COMPANY

601 N.W. 65th Court - Fort Lauderdale, FL 33309

Phone: (954) 776-5471 - Fax: (800) 776-5529

<http://www.fhp-mfg.com>



PACKAGED UNITS SPECIFICATION DATA SHEET

FHP MANUFACTURING HIGH-EFFICIENCY WATER SOURCE HEAT PUMPS

EM051

ENERGY-MISER

ELECTRICAL SPECIFICATIONS

Electrical Characteristics	Elect. Symbol	Compressor		Blower		Loop Pump		Min. Circuit Amps	Max. Fuse/Breaker
		RLA	LRA	FLA	HP	FLA	HP		
208/230-1-60	-1	19.3	102.0	5.2	3/4			29.3	45
208/230-3-60	-3	12.9	91.0	5.2	3/4	-	-	21.3	30
460-3-60	-4	6.4	42.0	2.5	3/4	-	-	10.5	15
575-3-60	-5	5.2	39.0	2.6	3/4	-	-	9.1	15

MECHANICAL SPECIFICATIONS

Refrigerant: R-22			
Air Coil			
Square Feet	Rows Deep	Tube O.D.	Fins/Inch
4.10	3	3/8	14
Water Coil			
Type	Work Press		
Coaxial	450 psig		
Blower Size	Compr Type		
10x8 DD	Reciprocating		
Net Weight	Ship Weight		
310 lbs	334 lbs		

BLOWER PERFORMANCE

Available External Static Pressure (Inches of Water, Gauge. Wet Coil and Filter Included)												
Blower Speed	0.10	0.20	0.30	0.40	0.50	0.60	0.70	0.80	0.90	1.00	1.10	1.20
High	1650	1630	1610	1530	1500	1440	1400	1340	1250	-	-	-
Medium	1615	1590	1540	1475	1450	1410	1380	1275	-	-	-	-
Low	1585	1560	1510	1440	1425	1335	-	-	-	-	-	-



FLUID PRESSURE DROP

Fluid Flow (GPM)	Pressure Drop	
	(FOH)	(PSIG)
6	2.94	1.27
9	6.10	2.64
12	10.23	4.43
14	13.51	5.85
16	17.18	7.44

ISO 13256-1 CERTIFIED PERFORMANCE DATA Rated at 1,500 CFM and 12.0 GPM

Water Loop				Ground Water				Ground Loop (Ext. Range Required)			
Cooling		Heating		Cooling		Heating		Cooling		Heating	
Capacity	EER	Capacity	COP	Capacity	EER	Capacity	COP	Capacity	EER	Capacity	COP
47,500	12.8	62,000	4.6	54,000	18.0	49,500	4.0	50,000	14.4	37,500	3.5



CAPACITY DATA All performance at 1,500 CFM and 12.0 GPM

COOLING

EFT Range (Standard) 50°F to 100°F
EFT Range (Ext. Range Option) 45°F to 110°F

Entering Fluid Temp. (°F)	Entering Air Temp. (°F)	Total Capacity (MBtuH)	Sensible Capacity (MBtuH)	Sensible to Total Ratio	Power Input (kW)	Heat of Reject (MBtuH)	EER
50°	70°db 61°wb	48.04	31.71	0.66	2.92	58.00	16.5
60°		46.16	30.72	0.67	3.18	57.02	14.5
70°		44.27	29.83	0.67	3.45	56.04	12.8
85°		41.43	28.65	0.69	3.85	54.57	10.8
100°		38.60	27.63	0.72	4.25	53.10	9.1
50°	75°db 63°wb	51.49	37.93	0.74	2.93	61.50	17.5
60°		49.46	36.74	0.74	3.20	60.39	15.4
70°		47.44	35.68	0.75	3.47	59.28	13.7
85°		44.41	34.28	0.77	3.87	57.62	11.5
100°		41.37	33.06	0.80	4.27	55.96	9.7
50°	80°db 67°wb	56.52	41.88	0.74	2.96	66.61	19.1
60°		54.30	40.58	0.75	3.23	65.31	16.8
70°		52.08	39.41	0.76	3.50	64.02	14.9
85°		48.76	37.87	0.78	3.90	62.07	12.5
100°		45.43	36.52	0.80	4.31	60.13	10.5
50°	85°db 71°wb	61.55	45.88	0.75	2.98	71.72	20.7
60°		59.14	44.45	0.75	3.25	70.23	18.2
70°		56.73	43.17	0.76	3.52	68.75	16.1
85°		53.11	41.49	0.78	3.93	66.53	13.5
100°		49.49	40.01	0.81	4.34	64.30	11.4

HEATING

EFT Range (Standard) 50°F to 80°F
EFT Range (Ext. Range Option) 25°F to 80°F

Entering Fluid Temp. (°F)	Entering Air Temp. (°F)	Total Capacity (MBtuH)	Power Input (kW)	Heat of Abs. (MBtuH)	COP
50°	60°	51.90	3.51	39.92	4.3
60°		56.81	3.59	44.55	4.6
70°		61.72	3.67	49.18	4.9
80°		66.64	3.76	53.82	5.2
50°		70°	49.07	3.57	36.88
60°	53.72		3.66	41.23	4.3
70°	58.36		3.74	45.59	4.6
80°	63.00		3.82	49.95	4.8
50°	80°		45.76	3.65	33.30
60°		50.08	3.74	37.33	3.9
70°		54.40	3.82	41.36	4.2
80°		58.73	3.91	45.39	4.4

LOW TEMP HEATING

Extended Range Option Required
Antifreeze Required

25°	60°	38.84	3.30	27.56	3.4
30°		41.24	3.35	29.83	3.6
40°		46.06	3.43	34.36	3.9
25°	70°	36.73	3.36	25.25	3.2
30°		39.01	3.41	27.39	3.4
40°		43.56	3.49	31.65	3.7
25°	80°	34.26	3.44	22.54	2.9
30°		36.38	3.48	24.51	3.1
40°		40.62	3.56	28.45	3.3

Units are complete packages containing compressor, reversing valve, capillary tube metering device, and heat exchangers. Also included are safety controls: Overload protection for motors, high and low refrigerant pressure switches and a lock-out circuit.

Extended range option includes expansion valve metering device, insulated water coil and solid state lock-out controls.

Performance based on ARI/ISO rated air flow, fluid flow and voltage. For conditions other than rated, consult the FHP EAD selection software. Due to variations in installation actual performance may vary marginally from tabulated values.

As a result of continuing research and development, specifications are subject to change without notice.

FHP MANUFACTURING COMPANY

601 N.W. 65th Court - Fort Lauderdale, FL 33309

Phone: (954) 776-5471 - Fax: (800) 776-5529

<http://www.fhp-mfg.com>



PACKAGED UNITS SPECIFICATION DATA SHEET

FHP MANUFACTURING HIGH-EFFICIENCY WATER SOURCE HEAT PUMPS

EM060

ENERGY-MISER

ELECTRICAL SPECIFICATIONS

Electrical Characteristics	Elect. Symbol	Compressor		Blower		Loop Pump		Min. Circuit Amps	Max. Fuse/Breaker
		RLA	LRA	FLA	HP	FLA	HP		
208/230-1-60	-1	25.6	169.0	5.2	3/4	-	-	37.2	60
208/230-3-60	-3	17.7	123.0	5.2	3/4	-	-	27.3	45
460-3-60	-4	9.0	49.5	2.5	3/4	-	-	13.8	20
575-3-60	-5	7.2	40.0	2.6	3/4	-	-	11.6	15

MECHANICAL SPECIFICATIONS

Refrigerant: R-22			
Air Coil			
Square Feet	Rows Deep	Tube O.D.	Fins/Inch
4.50	3	3/8	14
Water Coil			
Type	Work Press		
Coaxial	450 psig		
Blower Size	Compr Type		
11x9 DD	Scroll		
Net Weight	Ship Weight		
363 lbs	387 lbs		

BLOWER PERFORMANCE

Available External Static Pressure (Inches of Water, Gauge. Wet Coil and Filter Included)												
Blower Speed	0.10	0.20	0.30	0.40	0.50	0.60	0.70	0.80	0.90	1.00	1.10	1.20
High	2160	2090	2030	1960	1870	1800	1730	1680	1640	1600	1550	1500
Medium	2110	2040	1990	1910	1820	1760	1690	1630	1600	-	-	-
Low	2060	1990	1950	1860	1760	1710	1640	-	-	-	-	-



FLUID PRESSURE DROP

Fluid Flow (GPM)	Pressure Drop	
	(FOH)	(PSIG)
8	3.45	1.50
10	5.16	2.23
13	8.28	3.58
15	10.71	4.64
20	17.97	7.78

ISO 13256-1 CERTIFIED PERFORMANCE DATA Rated at 2,000 CFM and 15.0 GPM

Water Loop				Ground Water				Ground Loop (Ext. Range Required)			
Cooling		Heating		Cooling		Heating		Cooling		Heating	
Capacity	EER	Capacity	COP	Capacity	EER	Capacity	COP	Capacity	EER	Capacity	COP
60,000	12.5	77,000	4.5	65,000	17.5	60,000	4	60,500	14	48,000	3.2



CAPACITY DATA All performance at 2,000 CFM and 15.0 GPM

COOLING							
EFT Range (Standard) 50°F to 100°F				EFT Range (Ext. Range Option) 45°F to 110°F			
Entering Fluid Temp. (°F)	Entering Air Temp. (°F)	Total Capacity (MBtuH)	Sensible Capacity (MBtuH)	Sensible to Total Ratio	Power Input (kW)	Heat of Reject (MBtuH)	EER
50°	70°db	56.34	36.73	0.65	3.41	67.98	16.51
60°		54.75	35.99	0.66	3.77	67.61	14.52
70°		53.16	35.39	0.67	4.13	67.24	12.88
85°		50.78	34.70	0.68	4.66	66.69	10.89
100°		48.40	34.23	0.71	5.20	66.14	9.31
50°	75°db	60.37	43.93	0.73	3.43	72.08	17.59
60°		58.67	43.05	0.73	3.79	71.61	15.48
70°		56.97	42.33	0.74	4.15	71.13	13.73
85°		54.42	41.51	0.76	4.69	70.42	11.61
100°		51.87	40.96	0.79	5.23	69.71	9.92
50°	80°db	66.27	48.51	0.73	3.46	78.07	19.17
60°		64.41	47.54	0.74	3.82	77.44	16.86
70°		62.54	46.75	0.75	4.18	76.82	14.96
85°		59.75	45.84	0.77	4.73	75.88	12.64
100°		56.95	45.23	0.79	5.27	74.94	10.81
50°	85°db	72.17	53.14	0.74	3.48	84.06	20.72
60°		70.14	52.08	0.74	3.85	83.28	18.22
70°		68.12	51.21	0.75	4.21	82.50	16.16
85°		65.08	50.22	0.77	4.76	81.33	13.67
100°		62.04	49.55	0.80	5.31	80.16	11.68

HEATING

HEATING					
EFT Range (Standard) 50°F to 80°F			EFT Range (Ext. Range Option) 25°F to 80°F		
Entering Fluid Temp. (°F)	Entering Air Temp. (°F)	Total Capacity (MBtuH)	Power Input (kW)	Heat of Abs. (MBtuH)	COP
50°	60°	65.74	4.81	49.33	4.01
60°		73.88	4.98	56.89	4.35
70°		82.02	5.15	64.46	4.67
80°		90.16	5.31	72.02	4.97
50°	70°	62.16	4.89	45.45	3.72
60°		69.85	5.07	52.56	4.04
70°		77.54	5.24	59.66	4.34
80°		85.23	5.41	66.76	4.61
50°	80°	57.95	5.00	40.88	3.39
60°		65.11	5.18	47.44	3.68
70°		72.28	5.35	54.00	3.95
80°		79.44	5.53	60.56	4.21

LOW TEMP HEATING

LOW TEMP HEATING					
Extended Range Option Required Antifreeze Required					
Entering Fluid Temp. (°F)	Entering Air Temp. (°F)	Total Capacity (MBtuH)	Power Input (kW)	Heat of Abs. (MBtuH)	COP
25°	60°	44.49	4.38	29.53	2.97
30°		48.48	4.47	33.23	3.18
40°		56.46	4.64	40.64	3.57
25°	70°	42.08	4.46	26.85	2.76
30°		45.85	4.55	30.33	2.95
40°		53.40	4.72	37.28	3.31
25°	80°	39.26	4.56	23.69	2.52
30°		42.77	4.65	26.90	2.70
40°		49.79	4.83	33.32	3.02

Units are complete packages containing compressor, reversing valve, capillary tube metering device, and heat exchangers. Also included are safety controls: Overload protection for motors, high and low refrigerant pressure switches and a lock-out circuit.

Extended range option includes expansion valve metering device, insulated water coil and solid state lock-out controls.

Performance based on ARI/ISO rated air flow, fluid flow and voltage. For conditions other than rated, consult the FHP EAD selection software. Due to variations in installation actual performance may vary marginally from tabulated values.

As a result of continuing research and development, specifications are subject to change without notice.



PACKAGED UNITS SPECIFICATION DATA SHEET

FHP MANUFACTURING HIGH-EFFICIENCY WATER SOURCE HEAT PUMPS

EM061

ENERGY-MISER

ELECTRICAL SPECIFICATIONS

Electrical Characteristics	Elect. Symbol	Compressor		Blower		Loop Pump		Min. Circuit Amps	Max. Fuse/Breaker
		RLA	LRA	FLA	HP	FLA	HP		
208/230-1-60	-1	25.6	169.0	5.2	3/4	-	-	37.2	60
208/230-3-60	-3	17.7	123.0	5.2	3/4	-	-	27.3	45
460-3-60	-4	9.0	49.5	2.5	3/4	-	-	13.8	20
575-3-60	-5	7.2	40.0	2.6	3/4	-	-	11.6	15

MECHANICAL SPECIFICATIONS

Refrigerant: R-22			
Air Coil			
Square Feet	Rows Deep	Tube O.D.	Fins/Inch
4.10	3	3/8	14
Water Coil			
Type	Work Press		
Coaxial	450 psig		
Blower Size	Compr Type		
11x9 DD	Scroll		
Net Weight	Ship Weight		
357 lbs	377 lbs		

BLOWER PERFORMANCE

Available External Static Pressure (Inches of Water, Gauge. Wet Coil and Filter Included)												
Blower Speed	0.10	0.20	0.30	0.40	0.50	0.60	0.70	0.80	0.90	1.00	1.10	1.20
High	2160	2090	2030	1960	1870	1800	1730	1680	1640	1600	1550	1500
Medium	2110	2040	1990	1910	1820	1760	1690	1630	1600	-	-	-
Low	2060	1990	1950	1860	1760	1710	1640	-	-	-	-	-



FLUID PRESSURE DROP

Fluid Flow (GPM)	Pressure Drop	
	(FOH)	(PSIG)
8	3.45	1.50
10	5.16	2.23
13	8.28	3.58
15	10.71	4.64
20	17.97	7.78

ISO 13256-1 CERTIFIED PERFORMANCE DATA Rated at 1,800 CFM and 15.0 GPM

Water Loop				Ground Water				Ground Loop (Ext. Range Required)			
Cooling		Heating		Cooling		Heating		Cooling		Heating	
Capacity	EER	Capacity	COP	Capacity	EER	Capacity	COP	Capacity	EER	Capacity	COP
58,000	13.3	70,000	4.5	62,000	19.0	57,000	4.0	60,000	15.2	45,000	3.4

CAPACITY DATA All performance at 1,800 CFM and 15.0 GPM

COOLING

EFT Range (Standard) 50°F to 100°F
EFT Range (Ext. Range Option) 45°F to 110°F

Entering Fluid Temp. (°F)	Entering Air Temp. (°F)	Total Capacity (MBtuH)	Sensible Capacity (MBtuH)	Sensible to Total Ratio	Power Input (kW)	Heat of Reject (MBtuH)	EER
50°	70°db 61°wb	53.33	35.02	0.66	3.06	63.78	17.4
60°		52.21	34.57	0.66	3.44	63.94	15.2
70°		51.10	34.27	0.67	3.81	64.11	13.4
85°		49.42	34.03	0.69	4.37	64.35	11.3
100°		47.75	34.05	0.71	4.94	64.60	9.7
50°	75°db 63°wb	57.19	41.99	0.73	3.08	67.69	18.6
60°		55.99	41.46	0.74	3.45	67.79	16.2
70°		54.80	41.09	0.75	3.83	67.88	14.3
85°		53.01	40.82	0.77	4.40	68.01	12.1
100°		51.21	40.84	0.80	4.96	68.15	10.3
50°	80°db 67°wb	62.83	46.42	0.74	3.10	73.41	20.3
60°		61.52	45.84	0.75	3.48	73.40	17.7
70°		60.21	45.44	0.75	3.86	73.39	15.6
85°		58.25	45.13	0.77	4.43	73.37	13.1
100°		56.28	45.15	0.80	5.00	73.35	11.3
50°	85°db 71°wb	68.48	50.90	0.74	3.12	79.13	21.9
60°		67.05	50.27	0.75	3.51	79.02	19.1
70°		65.63	49.82	0.76	3.89	78.90	16.9
85°		63.49	49.49	0.78	4.46	78.72	14.2
100°		61.35	49.51	0.81	5.04	78.55	12.2

Units are complete packages containing compressor, reversing valve, capillary tube metering device, and heat exchangers. Also included are safety controls: Overload protection for motors, high and low refrigerant pressure switches and a lock-out circuit.

Extended range option includes expansion valve metering device, insulated water coil and solid state lock-out controls.

Performance based on ARI/ISO rated air flow, fluid flow and voltage. For conditions other than rated, consult the FHP EAD selection software. Due to variations in installation actual performance may vary marginally from tabulated values.

As a result of continuing research and development, specifications are subject to change without notice.

EM061ip6 mod2 Rev: 6-02

HEATING

EFT Range (Standard) 50°F to 80°F
EFT Range (Ext. Range Option) 25°F to 80°F

Entering Fluid Temp. (°F)	Entering Air Temp. (°F)	Total Capacity (MBtuH)	Power Input (kW)	Heat of Abs. (MBtuH)	COP
50°	60°	62.77	4.46	47.53	4.1
60°		69.98	4.65	54.11	4.4
70°		77.19	4.84	60.69	4.7
80°		84.41	5.02	67.27	4.9
50°		70°	59.38	4.54	43.88
60°	66.19		4.73	50.04	4.1
70°	73.01		4.92	56.21	4.3
80°	79.82		5.11	62.38	4.6
50°	80°		55.40	4.64	39.57
60°		61.75	4.83	45.25	3.7
70°		68.09	5.03	50.94	4.0
80°		74.44	5.22	56.62	4.2

LOW TEMP HEATING

Extended Range Option Required
Antifreeze Required

25°	60°	43.86	4.00	30.21	3.2
30°		47.39	4.09	33.43	3.4
40°		54.47	4.28	39.86	3.7
25°	70°	41.51	4.07	27.63	3.0
30°		44.85	4.16	30.64	3.2
40°		51.53	4.35	36.68	3.5
25°	80°	38.76	4.15	24.58	2.7
30°		41.87	4.25	27.36	2.9
40°		48.09	4.44	32.92	3.2

FHP MANUFACTURING COMPANY

601 N.W. 65th Court - Fort Lauderdale, FL 33309

Phone: (954) 776-5471 - Fax: (800) 776-5529

<http://www.fhp-mfg.com>



PACKAGED UNITS SPECIFICATION DATA SHEET

FHP MANUFACTURING HIGH-EFFICIENCY WATER SOURCE HEAT PUMPS

EM070

ENERGY-MISER

ELECTRICAL SPECIFICATIONS

Electrical Characteristics	Elect. Symbol	Compressor		Blower		Loop Pump		Min. Circuit Amps	Max. Fuse/Breaker
		RLA	LRA	FLA	HP	FLA	HP		
208/230-1-60	-1	28.8	169.0	5.2	3/4	-	-	43.5	70
208/230-3-60	-3	19.1	123.0	5.2	3/4	-	-	29.1	45
460-3-60	-4	9.1	62.0	2.5	3/4	-	-	13.9	20
575-3-60	-5	7.2	50.0	2.6	3/4	-	-	11.6	15

MECHANICAL SPECIFICATIONS

Refrigerant: R-22			
Air Coil			
Square Feet	Rows Deep	Tube O.D.	Fins/Inch
6.00	3	3/8	14
Water Coil			
Type	Work Press		
Coaxial	450 psig		
Blower Size	Compr Type		
11x9 DD	Scroll		
Net Weight	Ship Weight		
427 lbs	452 lbs		

BLOWER PERFORMANCE

Available External Static Pressure (Inches of Water, Gauge. Wet Coil and Filter Included)												
Blower Speed	0.10	0.20	0.30	0.40	0.50	0.60	0.70	0.80	0.90	1.00	1.10	1.20
High	2260	2229	2202	2177	2139	2093	2040	1977	1917	1855	1790	1729
Medium	1990	1961	1945	1930	1908	1876	1838	1795	1750	1700	1646	-
Low	1720	1692	1687	1682	1677	1659	1635	1613	1583	1545	-	-



FLUID PRESSURE DROP

Fluid Flow (GPM)	Pressure Drop	
	(FOH)	(PSIG)
8	4.3	1.9
10	6.4	2.8
12	8.9	3.8
16	14.9	6.5
20	22.3	9.6

ISO 13256-1 CERTIFIED PERFORMANCE DATA Rated at 2,200 CFM and 16.0 GPM

Water Loop				Ground Water				Ground Loop (Ext. Range Required)			
Cooling		Heating		Cooling		Heating		Cooling		Heating	
Capacity	EER	Capacity	COP	Capacity	EER	Capacity	COP	Capacity	EER	Capacity	COP
68,000	12.5	82,000	4.6	76,000	18.7	66,000	3.8	69,000	13.9	53,000	3.4



CAPACITY DATA All performance at 2,200 CFM and 16.0 GPM

COOLING

EFT Range (Standard) 50°F to 100°F
EFT Range (Ext. Range Option) 45°F to 110°F

Entering Fluid Temp. (°F)	Entering Air Temp. (°F)	Total Capacity (MBtuH)	Sensible Capacity (MBtuH)	Sensible to Total Ratio	Power Input (kW)	Heat of Reject (MBtuH)	EER
50°	70°db	66.53	43.94	0.66	3.70	79.15	18.0
60°		63.97	42.60	0.67	4.20	78.30	15.2
70°		61.41	41.41	0.67	4.70	77.45	13.1
85°		57.57	39.84	0.69	5.45	76.18	10.6
100°		53.74	38.49	0.72	6.20	74.91	8.7
50°	75°db	71.29	52.54	0.74	3.72	83.98	19.2
60°		68.55	50.95	0.74	4.22	82.96	16.2
70°		65.81	49.52	0.75	4.73	81.94	13.9
85°		61.70	47.66	0.77	5.48	80.41	11.3
100°		57.59	46.04	0.80	6.24	78.88	9.2
50°	80°db	78.25	58.01	0.74	3.75	91.04	20.9
60°		75.25	56.25	0.75	4.25	89.77	17.7
70°		72.25	54.69	0.76	4.76	88.50	15.2
85°		67.74	52.63	0.78	5.53	86.60	12.3
100°		63.23	50.85	0.80	6.29	84.70	10.1
50°	85°db	85.21	63.54	0.75	3.77	98.10	22.6
60°		81.95	61.61	0.75	4.29	96.58	19.1
70°		78.68	59.90	0.76	4.80	95.06	16.4
85°		73.78	57.65	0.78	5.57	92.78	13.2
100°		68.88	55.70	0.81	6.34	90.51	10.9

HEATING

EFT Range (Standard) 50°F to 80°F
EFT Range (Ext. Range Option) 25°F to 80°F

Entering Fluid Temp. (°F)	Entering Air Temp. (°F)	Total Capacity (MBtuH)	Power Input (kW)	Heat of Abs. (MBtuH)	COP
50°	60°	71.44	5.04	54.24	4.2
60°		79.55	5.22	61.74	4.5
70°		87.67	5.40	69.24	4.8
80°		95.78	5.58	76.74	5.0
50°		70°	67.55	5.13	50.04
60°	75.21		5.31	57.08	4.1
70°	82.88		5.50	64.12	4.4
80°	90.54		5.68	71.16	4.7
50°	80°		62.98	5.24	45.09
60°		70.12	5.43	51.59	3.8
70°		77.26	5.62	58.09	4.0
80°		84.40	5.80	64.59	4.3

LOW TEMP HEATING

Extended Range Option Required
Antifreeze Required

25°	60°	50.15	4.59	34.48	3.2
30°		54.13	4.68	38.15	3.4
40°		62.08	4.86	45.50	3.7
25°	70°	47.44	4.67	31.49	3.0
30°		51.20	4.77	34.93	3.1
40°		58.71	4.95	41.82	3.5
25°	80°	44.25	4.78	27.95	2.7
30°		47.75	4.87	31.13	2.9
40°		54.75	5.06	37.49	3.2

Units are complete packages containing compressor, reversing valve, expansion valve metering device, and heat exchangers. Also included are safety controls: Overload protection for motors, high and low refrigerant pressure switches and a solid state lock-out circuit.

Extended range option includes insulated water coil.

Performance based on ARI/ISO rated air flow, fluid flow and voltage. For conditions other than rated, consult the FHP EAD selection software. Due to variations in installation actual performance may vary marginally from tabulated values.

As a result of continuing research and development, specifications are subject to change without notice.

EM070ip6 mod2 Rev: 6-02

FHP MANUFACTURING COMPANY

601 N.W. 65th Court - Fort Lauderdale, FL 33309

Phone: (954) 776-5471 - Fax: (800) 776-5529

<http://www.fhp-mfg.com>