

4SHP18LS

PRODUCT SPECIFICATIONS

18 SEER SPLIT SYSTEM ENHANCED HEAT PUMP

FORM NO. 4SHP18LS-100 (06/2014)



COMPONENTS

- Full metal louvered panels remove for easy coil cleaning and service
- Bi-directional filter drier for long-lasting durability and system protection
- Discharge muffler for quiet operation
- Factory installed crank case heater
- Factory installed high and low pressure switch
- Variable speed condenser fan motor with swept wing fan blade
- Advanced design defrost system featuring a smart logic for power consumption savings
- Service valves positioned for quick installation and easy service
- Trade available components
- Quiet Shift™ capable for sound control during defrost
- Communicating features
- Thermostat flexibility: works with the Comfort Sync T-Stat (when matched with communicating indoor unit) or a conventional 24V T-Stat
- Self diagnostics saves last 10 fault codes regardless of power interruption

DESIGN

- Designed for ambients up to 125°F

WARRANTY

10 year limited warranty on compressor, 10 year limited warranty on all parts, extended warranty available*

*Warranty provides for a total of 10 years of limited warranty coverage (Standard 5-year limited parts warranty plus an additional 5-year limited extended parts warranty). Warranty must be registered online within 60 days of installation to qualify for 10-year coverage. Unregistered equipment defaults to 5-year coverage. Lifetime limited heat exchanger warranty applies to registered equipment only (Standard 20 years with no online registration). See full warranty at www.alliedair.com for terms, conditions and exclusions.

COMPRESSOR

- High-efficiency 2 stage Copeland Ultra Tech™ scroll compressor
- R410a refrigerant
- Grommet mounted compressor for quiet operation
- Internally protected against high temperature motor overload conditions
- Heavy-duty compressor sound blanket for quiet operation

CABINET

- Full metal louvered panel coil guard protection
- Controls located in corner post for easy installation and service
- Rounded corners for safety and attractive, clean appearance
- Baked polyester paint finish over galvanized steel for maximum durability
- PVC coated wire fan discharge grill
- External gauge ports for easy service
- Raised base pan with ports allows for excellent water and debris drainage

COIL

- Enhanced aluminum fins and copper tubing for high efficiency and capacity
- Raised coil prevents debris from collecting in bottom of coil and causing loss of airflow



MODEL NUMBER GUIDE

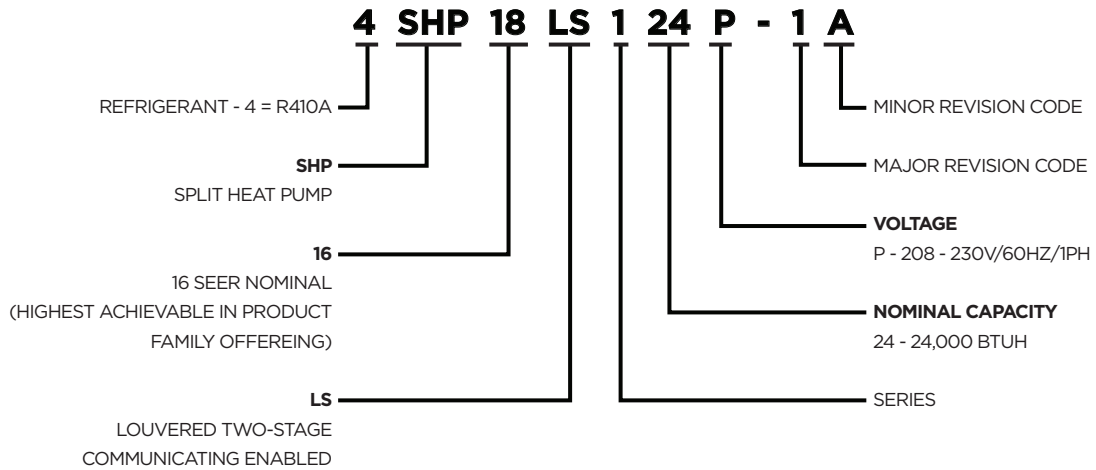

PHYSICAL AND ELECTRICAL

Model	Voltage/Hz/Phase	Voltage Range	Min. Circuit Amp.	Max. Over current Device (amps)	Compressor		Fan Motor			Refrigerant Line Connections		Refrig. Charge (oz.)	Weight (lbs.)
					Rated Load (amps)	Locked Rotor (amps)	Rated Load (amps)	Rated HP	Nom. RPM	Liquid O.D. (in.)	Vapor O.D. (in.)		
4SHP18LS124P-1	230-60/1	216-253	15.6	25	10.2	52	.7	1/3	825	3/8	7/8	300	341
4SHP18LS136P-1	230-60/1	216-253	23.7	40	16.6	82	.6	1/3	825	3/8	7/8	283	338
4SHP18LS148P-1	230-60/1	216-253	29.3	50	21.1	96	.8	1/3	825	3/8	7/8	262	338
4SHP18LS160P-1	230-60/1	216-253	34.4	60	25.6	118	.8	1/3	825	3/8	7/8	274	361

SOUND RATINGS

Model No.	Sound Rating dBA
4SHP18LS124P-1	72
4SHP18LS136P-1	75
4SHP18LS148P-1	75
4SHP18LS160P-1	75

DIMENSIONS (IN.)

Model No.	A	B	C
4SHP18LS124P-1	35.66	37.66	44
4SHP18LS136P-1	35.66	37.66	44
4SHP18LS148P-1	35.66	37.66	44
4SHP18LS160P-1	35.66	37.66	44

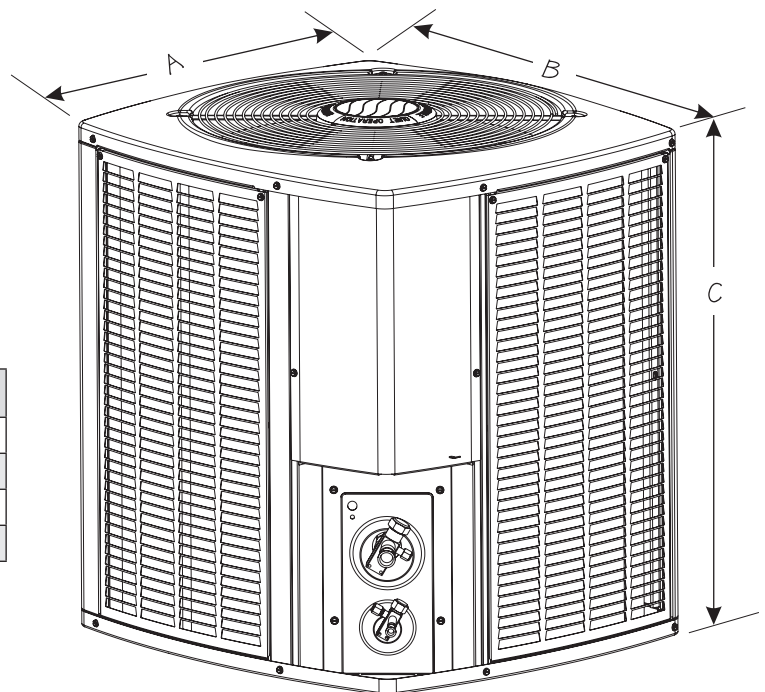

COOLING PERFORMANCE WITH AIR HANDLERS AND FURNACES

Outdoor Model	Indoor Model		Cooling				Heating				CFM	Refrigerant Connection				Refrig. Line Size		Indoor Expansion Device		
	Evaporator Coil or Air Handler ³	Furnaces	SEER	EER	ARI Rated Capacity ¹	Rated Sensible Capacity	HSPF	47		17		Outdoor		Indoor		Suction	Liquid	Piston ²	TXV	
								Btuh	COP	Btuh		COP	Suction	Liquid	Suction					Liquid
4SHP18LS124P	E(U,C,H)1P49C	EFV16CC	17.0	13.0	24,000	18,500	9.0	22,000	4.0	13,000	2.60	900	7/8	3/8	7/8	3/8	7/8	3/8	NA	H4TXV01
	E(U,C,H)1P49C	A95UH2V090C12S	16.5	13.0	24,000	18,500	8.5	22,000	4.0	13,000	2.60	900	7/8	3/8	7/8	3/8	7/8	3/8		
	E(U,C,H)1P49C	A95UH2V090C16S	16.5	13.0	24,000	18,500	8.5	22,000	4.0	13,000	2.60	900	7/8	3/8	7/8	3/8	7/8	3/8		
	E(U,C,H)1P49C	A96UHMV090C12 A97USMV090C12	16.5	13.0	24,000	18,500	8.5	22,000	4.0	13,000	2.60	900	7/8	3/8	7/8	3/8	7/8	3/8		
	E(U,C,H)1P49C	LBR,LUF****V14	16.5	13.0	24,000	18,500	8.5	22,000	4.0	13,000	2.60	900	7/8	3/8	7/8	3/8	7/8	3/8		
	E(U,C,H)1P49C	LHF,LHR,LUF****V12	16.5	13.0	24,000	18,500	8.5	22,000	4.0	13,000	2.60	900	7/8	3/8	7/8	3/8	7/8	3/8		
	E(U,C,H)1P49C	LUF,LBF,LBR****V14	16.5	13.0	24,000	18,500	8.5	22,000	4.0	13,000	2.60	900	7/8	3/8	7/8	3/8	7/8	3/8		
4SHP18LS136P	BCS2M48@00NA1P		17.0	12.5	35,000	26,300	8.5	34,000	3.5	22,000	2.70	1,200	7/8	3/8	7/8	3/8	7/8	3/8	NA	H4TXV01
	E(U,C,H)1P62C	EFV16CC	17.0	12.5	35,000	26,300	8.5	34,000	3.5	22,000	2.70	1,200	7/8	3/8	7/8	3/8	7/8	3/8		
	E(U,C,H)1P62C	A80+2V110C20	17.0	13.0	35,000	26,300	9.0	34,000	3.5	22,000	2.70	1,200	7/8	3/8	7/8	3/8	7/8	3/8		
	E(U,C,H)1P62C	A80#2V090C20	17.0	13.0	35,000	26,300	9.0	34,000	3.5	22,000	2.70	1,200	7/8	3/8	7/8	3/8	7/8	3/8		
	E(U,C,H)1P62C	A80#2V110C20	17.0	13.0	35,000	26,300	8.5	34,000	3.5	22,000	2.70	1,200	7/8	3/8	7/8	3/8	7/8	3/8		
	E(U,C,H)1P62C	A95DF1E090C16S	17.0	13.0	35,000	26,300	8.5	34,000	3.5	22,000	2.70	1,200	7/8	3/8	7/8	3/8	7/8	3/8		
	E(U,C,H)1P62C	A95DF2V090C20S	17.0	13.0	35,000	26,300	9.0	34,000	3.5	22,000	2.70	1,200	7/8	3/8	7/8	3/8	7/8	3/8		
	E(U,C,H)1P62C	A95DF2V110C20S	17.0	13.0	35,000	26,300	9.0	34,000	3.5	22,000	2.70	1,200	7/8	3/8	7/8	3/8	7/8	3/8		
	E(U,C,H)1P62C	A95UH1E090C16S	17.0	13.0	35,000	26,300	8.5	34,000	3.5	22,000	2.70	1,200	7/8	3/8	7/8	3/8	7/8	3/8		
	E(U,C,H)1P62C	A95UH2V090C12S	17.0	13.0	35,000	26,300	9.0	34,000	3.5	22,000	2.70	1,200	7/8	3/8	7/8	3/8	7/8	3/8		
	E(U,C,H)1P62C	A95UH2V090C16S	17.0	13.0	35,000	26,300	8.5	34,000	3.5	22,000	2.70	1,200	7/8	3/8	7/8	3/8	7/8	3/8		
	E(U,C,H)1P62C	A95UH2V090C20S	17.0	13.0	35,000	26,300	9.0	34,000	3.5	22,000	2.70	1,200	7/8	3/8	7/8	3/8	7/8	3/8		
	E(U,C,H)1P62C	A95UH2V110C16S	17.0	13.0	35,000	26,300	9.0	34,000	3.5	22,000	2.70	1,200	7/8	3/8	7/8	3/8	7/8	3/8		
	E(U,C,H)1P62C	A96DFMV090C16 A99DSMV090C16	17.0	13.0	35,000	26,300	9.0	34,000	3.5	22,000	2.70	1,200	7/8	3/8	7/8	3/8	7/8	3/8		
	E(U,C,H)1P62C	A96DFMV090C20 A97DSMV090C20	17.0	13.0	35,000	26,300	9.0	34,000	3.5	22,000	2.70	1,200	7/8	3/8	7/8	3/8	7/8	3/8		
	E(U,C,H)1P62C	A96DFMV110C20 A97DSMV110C20	17.0	13.0	35,000	26,300	9.0	34,000	3.5	22,000	2.70	1,200	7/8	3/8	7/8	3/8	7/8	3/8		
	E(U,C,H)1P62C	A96UHMV090C12 A97USMV090C12	17.0	13.0	35,000	26,300	9.0	34,000	3.5	22,000	2.70	1,200	7/8	3/8	7/8	3/8	7/8	3/8		
	E(U,C,H)1P62C	A96UHMV090C16 A97USMV090C16	17.0	13.0	35,000	26,300	9.0	34,000	3.5	22,000	2.70	1,200	7/8	3/8	7/8	3/8	7/8	3/8		
	E(U,C,H)1P62C	A96UHMV110C20 A97USMV110C20	17.0	13.0	35,000	26,300	9.0	34,000	3.5	22,000	2.70	1,200	7/8	3/8	7/8	3/8	7/8	3/8		
	E(U,C,H)1P62C	LBR,LUF****V14	16.0	12.0	35,000	26,300	9.0	34,000	3.5	22,000	2.70	1,200	7/8	3/8	7/8	3/8	7/8	3/8		
E(U,C,H)1P62C	LHF,LHR,LUF****V12	16.0	12.0	35,000	26,300	8.5	34,000	3.5	22,000	2.70	1,200	7/8	3/8	7/8	3/8	7/8	3/8			
E(U,C,H)1P62C	LUF,LBF,LBR****V14	16.0	12.0	35,000	26,300	9.0	34,000	3.5	22,000	2.70	1,200	7/8	3/8	7/8	3/8	7/8	3/8			

+ DF or DS
UH or US
@ V or S

Note:

1 Certified in accordance with Unitary Air Conditioner Certification Program, which is based on AHRI Standard 210/240

2 Required to achieve AHRI rating. If NA (Not Applicable) is in the piston column, then TXV is required.

3 A blower time delay relay is required to achieve AHRI rating. This feature is standard on all Allied Air Enterprises furnace and AH products.

COOLING PERFORMANCE WITH AIR HANDLERS AND FURNACES

Outdoor Model	Indoor Model		Cooling				Heating				CFM	Refrigerant Connection				Refrig. Line Size		Indoor Expansion Device		
			SEER	EER	ARI Rated Capacity ₁	Rated Sensible Capacity	HSPF	47		17		Outdoor		Indoor		Suction	Liquid	Piston ²	TXV	
	Btuh	COP						Btuh	COP	Suction		Liquid	Suction	Liquid						
	Evaporator Coil or Air Handler ³	Furnaces																		
4SHP18LS148P	BCS2M48@00NA1P		15.5	11.5	47,000	34,800	9.0	44,000	3.3	28,600	2.50	1,550	7/8	3/8	7/8	3/8	1 1/8	3/8		
	E(U,C,H)IP62C	EFV16CC	16.0	12.0	47,000	34,800	9.0	44,000	3.3	28,600	2.50	1,550	7/8	3/8	7/8	3/8	1 1/8	3/8		
	E(U,C,H)IP62D	EFV20DC	16.0	12.0	47,000	34,800	8.5	44,000	3.3	28,600	2.50	1,600	7/8	3/8	7/8	3/8	1 1/8	3/8		
	E(U,C,H)IP62C	A80DF1E110C20	16.0	12.0	47,000	34,800	8.5	44,000	3.3	28,600	2.50	1,550	7/8	3/8	7/8	3/8	1 1/8	3/8		
	E(U,C,H)IP62C	A80+2V110C20	16.0	12.0	47,000	34,800	9.0	44,000	3.3	28,600	2.50	1,550	7/8	3/8	7/8	3/8	1 1/8	3/8		
	E(U,C,H)IP62C	A80UH1E090C20*	16.0	12.0	47,000	34,800	8.5	44,000	3.3	28,600	2.50	1,550	7/8	3/8	7/8	3/8	1 1/8	3/8		
	E(U,C,H)IP62C	A80UH1E110C20*	16.0	12.0	47,000	34,800	8.5	44,000	3.3	28,600	2.50	1,550	7/8	3/8	7/8	3/8	1 1/8	3/8		
	E(U,C,H)IP62C	A80#2V090C20	16.0	12.0	47,000	34,800	9.0	44,000	3.3	28,600	2.50	1,550	7/8	3/8	7/8	3/8	1 1/8	3/8		
	E(U,C,H)IP62C	A80#2V110C20	16.0	12.0	47,000	34,800	9.0	44,000	3.3	28,600	2.50	1,550	7/8	3/8	7/8	3/8	1 1/8	3/8		
	E(U,C,H)IP62D	A80#2V135D20	15.5	12.0	47,000	34,800	8.5	44,000	3.3	28,600	2.50	1,550	7/8	3/8	7/8	3/8	1 1/8	3/8		
	E(U,C,H)IP62C	A95DF1E090C16S	16.0	12.0	47,000	34,800	8.5	44,000	3.3	28,600	2.50	1,550	7/8	3/8	7/8	3/8	1 1/8	3/8		
	E(U,C,H)IP62C	A95DF1E110C20S	16.0	12.0	47,000	34,800	8.5	44,000	3.3	28,600	2.50	1,550	7/8	3/8	7/8	3/8	1 1/8	3/8		
	E(U,C,H)IP62C	A95DF2V090C20S	16.0	12.0	47,000	34,800	8.5	44,000	3.3	28,600	2.50	1,550	7/8	3/8	7/8	3/8	1 1/8	3/8		
	E(U,C,H)IP62C	A95DF2V110C20S	16.0	12.0	47,000	34,800	8.5	44,000	3.3	28,600	2.50	1,550	7/8	3/8	7/8	3/8	1 1/8	3/8		
	E(U,C,H)IP62C	A95UH1E090C16S	16.0	12.0	47,000	34,800	8.5	44,000	3.3	28,600	2.50	1,550	7/8	3/8	7/8	3/8	1 1/8	3/8		
	E(U,C,H)IP62C	A95UH1E110C20S	16.0	12.0	47,000	34,800	8.5	44,000	3.3	28,600	2.50	1,550	7/8	3/8	7/8	3/8	1 1/8	3/8		
	E(U,C,H)IP62C	A95UH2V090C16S	16.0	12.0	47,000	34,800	8.5	44,000	3.3	28,600	2.50	1,550	7/8	3/8	7/8	3/8	1 1/8	3/8		
	E(U,C,H)IP62C	A95UH2V090C20S	16.0	12.0	47,000	34,800	8.5	44,000	3.3	28,600	2.50	1,550	7/8	3/8	7/8	3/8	1 1/8	3/8		
	E(U,C,H)IP62C	A95UH2V110C16S	16.0	12.0	47,000	34,800	8.5	44,000	3.3	28,600	2.50	1,550	7/8	3/8	7/8	3/8	1 1/8	3/8		
	E(U,C,H)IP62C	A95UH2V110C20S	16.0	12.0	47,000	34,800	8.5	44,000	3.3	28,600	2.50	1,550	7/8	3/8	7/8	3/8	1 1/8	3/8		
	E(U,C,H)IP62D	A95UH2V135D20S	16.0	12.0	47,000	34,800	8.5	44,000	3.3	28,600	2.50	1,550	7/8	3/8	7/8	3/8	1 1/8	3/8		
	E(U,C,H)IP62C	A96DFMV090C16 A97DSMV090C16	15.5	12.0	47,000	34,800	9.0	44,000	3.3	28,600	2.50	1,550	7/8	3/8	7/8	3/8	1 1/8	3/8		
	E(U,C,H)IP62C	A96DFMV090C20 A97DSMV090C20	15.5	12.0	47,000	34,800	9.0	44,000	3.3	28,600	2.50	1,550	7/8	3/8	7/8	3/8	1 1/8	3/8		
	E(U,C,H)IP62C	A96DFMV110C20 A97DSMV110C20	16.0	12.0	47,000	34,800	9.0	44,000	3.3	28,600	2.50	1,550	7/8	3/8	7/8	3/8	1 1/8	3/8		
	E(U,C,H)IP62C	A96UHMV090C16 A97USMV090C16	15.5	12.0	47,000	34,800	8.5	44,000	3.3	28,600	2.50	1,550	7/8	3/8	7/8	3/8	1 1/8	3/8		
	E(U,C,H)IP62C	A96UHMV090C20 A97USMV090C20	15.5	12.0	47,000	34,800	8.5	44,000	3.3	28,600	2.50	1,550	7/8	3/8	7/8	3/8	1 1/8	3/8		
	E(U,C,H)IP62C	A96UHMV110C20 A97USMV110C20	16.0	12.0	47,000	34,800	8.5	44,000	3.3	28,600	2.50	1,550	7/8	3/8	7/8	3/8	1 1/8	3/8		
	E(U,C,H)IP62D	A96UHMV135D20 A97USMV135D20	16.0	12.0	47,000	34,800	8.5	44,000	3.3	28,600	2.50	1,550	7/8	3/8	7/8	3/8	1 1/8	3/8		
	E(U,C,H)IP62D	LUF*****V20	16.0	12.0	47,000	34,800	8.5	44,000	3.3	28,600	2.50	1,550	7/8	3/8	7/8	3/8	1 1/8	3/8		

NA

H4TXV03

+ DF or DS
UH or US
@ V or S

Note:

1 Certified in accordance with Unitary Air Conditioner Certification Program, which is based on AHRI Standard 210/240
2 Required to achieve AHRI rating. If NA (Not Applicable) is in the piston column, then TXV is required.
3 A blower time delay relay is required to achieve AHRI rating. This feature is standard on all Allied Air Enterprises furnace and AH products.

COOLING PERFORMANCE WITH AIR HANDLERS AND FURNACES

Outdoor Model	Indoor Model		Cooling				Heating				CFM	Refrigerant Connection				Refrig. Line Size		Indoor Expansion Device		
	Evaporator Coil or Air Handler ³	Furnaces	SEER	EER	ARI Rated ₁ Capacity	Rated Sensible Capacity	HSPF	47		17		Outdoor		Indoor		Suction	Liquid	Piston ²	TXV	
								Btuh	COP	Btuh		COP	Suction	Liquid						
															Suction					Liquid
4SHP18LS16OP	BCS2M60@00NA1P		15.5	11.0	56,000	42,000	9.0	55,000	3.5	37,000	2.50	1,800	7/8	3/8	7/8	3/8	1 1/8	3/8	NA	H4TXV03
	E(U,C,H)1P62C	EFV16CC	15.0	11.0	56,000	42,000	9.0	55,000	3.5	37,000	2.50	1,800	7/8	3/8	7/8	3/8	1 1/8	3/8		
	E(U,C,H)1P62D	EFV20DC	15.0	11.0	56,000	42,000	9.0	55,000	3.5	37,000	2.50	1,800	7/8	3/8	7/8	3/8	1 1/8	3/8		
	E(U,C,H)1P62C	A80DF1E110C20	15.0	11.0	56,000	42,000	9.0	55,000	3.5	37,000	2.50	1,800	7/8	3/8	7/8	3/8	1 1/8	3/8		
	E(U,C,H)1P62C	A80+2V110C20	15.0	11.0	56,000	42,000	9.0	55,000	3.5	37,000	2.50	1,800	7/8	3/8	7/8	3/8	1 1/8	3/8		
	E(U,C,H)1P62C	A80UH1E090C20*	15.0	11.0	56,000	42,000	9.0	55,000	3.5	37,000	2.50	1,900	7/8	3/8	7/8	3/8	1 1/8	3/8		
	E(U,C,H)1P62C	A80UH1E110C20*	15.0	11.0	56,000	42,000	9.0	55,000	3.5	37,000	2.50	1,900	7/8	3/8	7/8	3/8	1 1/8	3/8		
	E(U,C,H)1P62D	A80UH1E135D20*	14.5	11.0	56,000	42,000	9.0	55,000	3.5	37,000	2.50	1,800	7/8	3/8	7/8	3/8	1 1/8	3/8		
	E(U,C,H)1P62C	A80#2V090C20	15.0	11.0	56,000	42,000	9.0	55,000	3.5	37,000	2.50	1,800	7/8	3/8	7/8	3/8	1 1/8	3/8		
	E(U,C,H)1P62C	A80#2V110C20	15.0	11.0	56,000	42,000	9.0	55,000	3.5	37,000	2.50	1,800	7/8	3/8	7/8	3/8	1 1/8	3/8		
	E(U,C,H)1P62D	A80#2V135D20	15.0	11.0	56,000	42,000	9.0	55,000	3.5	37,000	2.50	1,800	7/8	3/8	7/8	3/8	1 1/8	3/8		
	E(U,C,H)1P62C	A95DF1E110C20S	15.0	11.0	56,000	42,000	9.0	55,000	3.5	37,000	2.50	1,900	7/8	3/8	7/8	3/8	1 1/8	3/8		
	E(U,C,H)1P62C	A95DF2V090C20S	15.0	11.0	56,000	42,000	9.0	55,000	3.5	37,000	2.50	1,800	7/8	3/8	7/8	3/8	1 1/8	3/8		
	E(U,C,H)1P62C	A95DF2V110C20S	15.0	11.0	56,000	42,000	9.0	55,000	3.5	37,000	2.50	1,800	7/8	3/8	7/8	3/8	1 1/8	3/8		
	E(U,C,H)1P62C	A95UH1E110C20S	15.0	11.0	56,000	42,000	9.0	55,000	3.5	37,000	2.50	1,900	7/8	3/8	7/8	3/8	1 1/8	3/8		
	E(U,C,H)1P62D	A95UH1E135D20S	14.5	11.0	56,000	42,000	9.0	55,000	3.5	37,000	2.50	1,800	7/8	3/8	7/8	3/8	1 1/8	3/8		
	E(U,C,H)1P62C	A95UH2V090C20S	15.0	11.0	56,000	42,000	9.0	55,000	3.5	37,000	2.50	1,800	7/8	3/8	7/8	3/8	1 1/8	3/8		
	E(U,C,H)1P62C	A95UH2V110C20S	15.0	11.0	56,000	42,000	9.0	55,000	3.5	37,000	2.50	1,800	7/8	3/8	7/8	3/8	1 1/8	3/8		
	E(U,C,H)1P62D	A95UH2V135D20S	14.5	11.0	56,000	42,000	9.0	55,000	3.5	37,000	2.50	1,800	7/8	3/8	7/8	3/8	1 1/8	3/8		
	E(U,C,H)1P62C	A96DFMV090C20 A97DSMV090C20	15.0	11.0	56,000	42,000	9.0	55,000	3.5	37,000	2.50	1,800	7/8	3/8	7/8	3/8	1 1/8	3/8		
	E(U,C,H)1P62C	A96DFMV110C20 A97DSMV110C20	15.0	11.0	56,000	42,000	9.0	55,000	3.5	37,000	2.50	1,800	7/8	3/8	7/8	3/8	1 1/8	3/8		
	E(U,C,H)1P62C	A96UHMV090C20 A97USMV090C20	15.0	11.0	56,000	42,000	9.0	55,000	3.5	37,000	2.50	1,800	7/8	3/8	7/8	3/8	1 1/8	3/8		
	E(U,C,H)1P62C	A96UHMV110C20 A97USMV110C20	15.0	11.0	56,000	42,000	9.0	55,000	3.5	37,000	2.50	1,800	7/8	3/8	7/8	3/8	1 1/8	3/8		
	E(U,C,H)1P62D	A96UHMV135D20 A97USMV135D20	15.0	11.0	56,000	42,000	9.0	55,000	3.5	37,000	2.50	1,800	7/8	3/8	7/8	3/8	1 1/8	3/8		
E(U,C,H)1P62D	LUF*****V20	14.0	11.0	56,000	42,000	9.0	56,000	3.5	37,000	2.50	1,800	7/8	3/8	7/8	3/8	1 1/8	3/8			

+ DF or DS
UH or US
@ V or S

Note:

1 Certified in accordance with Unitary Air Conditioner Certification Program, which is based on AHRI Standard 210/240

2 Required to achieve AHRI rating. If NA (Not Applicable) is in the piston column, then TXV is required.

3 A blower time delay relay is required to achieve AHRI rating. This feature is standard on all Allied Air Enterprises furnace and AH products.

COOLING PERFORMANCE EXTENDED RATINGS

Outdoor Model	Indoor Model	Indoor Temp DB/WB °F	Outdoor Temp - DB°F														
			65			82			95			105			115		
			Btuh	S/T	kW	Btuh	S/T	kW	Btuh	S/T	kW	Btuh	S/T	kW	Btuh	S/T	kW
4SHP18LS124P-1	EC1P49C+EVF16	85/72	32,900	.68	1.34	30,200	.70	1.64	28,100	.72	1.87	26,500	.73	2.04	24,900	.74	2.22
		80/67	30,200	.76	1.31	27,700	.77	1.61	25,800	.78	1.84	24,300	.79	2.02	22,900	.80	2.19
		75/63	28,500	.79	1.29	25,900	.79	1.59	23,900	.79	1.82	22,400	.79	2.00	20,800	.79	2.17
4SHP18LS136P-1	BCS2M48V BCS2M48S	85/72	46,500	.65	2.10	43,200	.67	2.54	40,700	.69	2.88	38,800	.70	3.14	36,900	.72	3.41
		80/67	42,800	.73	2.06	39,700	.74	2.50	37,400	.75	2.84	35,600	.76	3.10	33,800	.77	3.36
		75/63	40,400	.76	2.03	37,100	.76	2.47	34,600	.76	2.81	32,700	.76	3.07	30,800	.76	3.33
4SHP18LS148P1	BCS2M48V BCS2M48S	85/72	61,400	.64	3.01	55,900	.67	3.55	51,700	.70	3.96	48,500	.72	4.27	45,200	.74	4.59
		80/67	56,400	.71	2.95	51,300	.74	3.49	47,500	.76	3.90	44,500	.78	4.22	41,500	.79	4.53
		75/63	53,400	.75	2.91	47,900	.76	3.45	44,000	.77	3.86	41,000	.78	4.17	38,000	.79	4.49
4SHP18 LS160P1	BCS2M60V BCS2M60S	85/72	72,600	.62	3.85	66,600	.64	4.60	62,000	.66	5.17	58,500	.67	5.60	54,900	.69	6.04
		80/67	66,800	.70	3.77	61,200	.71	4.52	56,900	.72	5.00	53,700	.73	5.53	50,400	.74	5.97
		75/63	62,900	.73	3.72	57,100	.73	4.47	52,700	.73	5.03	49,300	.73	5.47	45,900	.73	5.91

HEATING PERFORMANCE EXTENDED RATINGS

Outdoor Model	Indoor Model	Outdoor Temp - DB/WB °F														
		0/0			17/15			35/33			47/43			62/56		
		Btuh	S/T	kW	Btuh	S/T	kW	Btuh	S/T	kW	Btuh	S/T	kW	Btuh	S/T	kW
4SHP18LS124P-1	ECIP49C+EVF16	7,800	1.84	1.40	14,000	2.71	1.51	20,400	3.63	1.63	24,700	4.24	1.71	30,100	5.01	1.81
4SHP18LS136P-1	BCS2M48V BCS2M48S	14,500	2.26	2.17	22,300	2.72	2.39	30,500	3.21	2.62	36,000	3.53	2.77	42,800	3.94	2.96
4SHP18LS148P-1	BCS2M48V BCS2M48S	20,000	2.11	3.00	29,400	2.59	3.34	39,500	3.09	3.70	46,200	3.43	3.94	54,500	3.85	4.24
4SHP18 LS160P-1	BCS2M60V BCS2M60S	24,900	1.95	4.06	36,700	2.35	4.59	49,100	2.77	5.15	57,500	3.05	5.53	67,900	3.40	6.00

ACCESSORIES

KIT NUMBER	DESCRIPTION	USED WITH
45F08	Compressor Low Ambient Cut-Off	All 4SHP18LS's
93G35	Freezestat (3/8" & 5/8")	All 4SHP18 LS's
10J42	Hard Start Kit	4SHP18LS 24-36
81J69	Hard Start Kit	4SHP18LS 48-60
54M89	Low Ambient Kit	All 4SHP18LS's
ASTAT503	Outdoor Thermostat	All 4SHP18LS's
ADFSTAT504	Discharge Tempering Thermostat	All 4SHP18LS's
1.851363	TXV Kit H4TXV01	4SHP18LS 24-36
1.851365	TXV Kit H4TXV03	4SHP18LS 48-60
85W66	Relay Kit - Constant Torque	All Constant Torque Furnaces



1-800-448-5872

All specifications and illustrations subject to change without notice and without incurring obligations.