

# INSTALLATION INSTRUCTIONS

## ⚠ WARNING

Improper installation, adjustment, alteration, service or maintenance can cause property damage, personal injury or loss of life. Installation and service must be performed by a qualified installer, service agency or the gas supplier

## ⚠ CAUTION

Danger of sharp metallic edges. Can cause injury. Take care when servicing unit to avoid accidental contact with sharp edges.

### Table Of Contents

Dimensions .....	Page 2
Parts Arrangements .....	Page 3
Shipping and Packing List .....	Page 4
General .....	Page 4
Requirements .....	Page 4
Unit Support .....	Page 5
Duct Connection .....	Page 5
Rigging Unit For Lifting .....	Page 5
Horizontal Air Discharge .....	Page 6
Condensate Drains .....	Page 6
Gas Piping .....	Page 7
Pressure Test Gas Piping .....	Page 7

## ZGA/ZCA036 ZGA/ZCA048 ZGA/ZCA060

3-, 4- and 5-Ton

GAS AND COOLING PACKAGED UNITS  
507110-01  
12/2012

Install Vent Cap .....	Page 8
High Altitude Derate .....	Page 8
Electrical Connections .....	Page 8
Blower Operation and Adjustments .....	Page 9
Cooling Start-Up .....	Page 18
Gas Heat Start-Up .....	Page 21
Heating Operation and Adjustments .....	Page 23
Electric Heat Start-Up .....	Page 23
Service .....	Page 24

**RETAIN THESE INSTRUCTIONS FOR FUTURE REFERENCE**

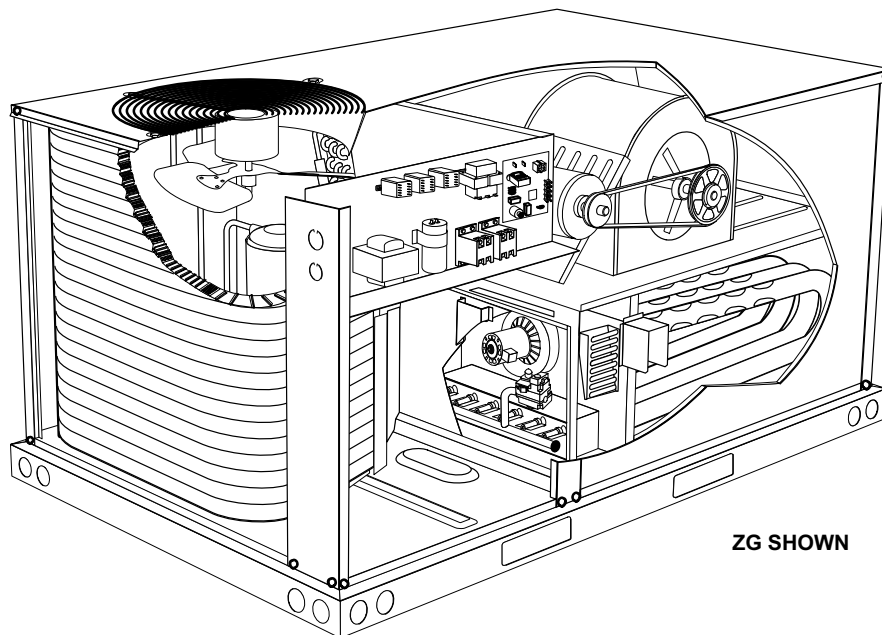

ZG SHOWN



**ZGA/ZCA036, 048, 060 DIMENSIONS in. - Gas heat section shown**

**BOTTOM POWER ENTRY**

Holes required for Optional Bottom Power Entry Kit

	Threaded Conduit Fittings (Provided in Kit)	Wire Use	Hole Diameter Required in Unit Base (Max.)
<b>A</b>	1/2	ACC.	7/8 (23)
<b>B</b>	1/2	24V	7/8 (23)
<b>C</b>	3/4	POWER	1-1/8 (29)

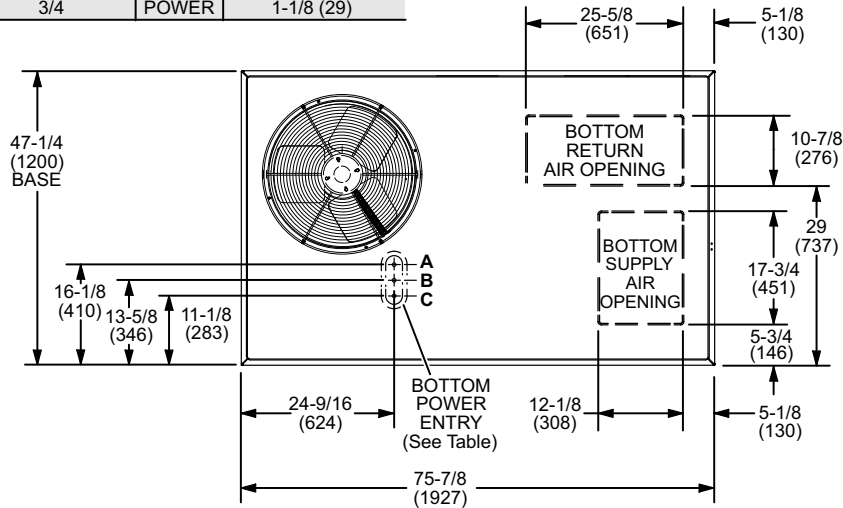

**TOP VIEW (Base)**

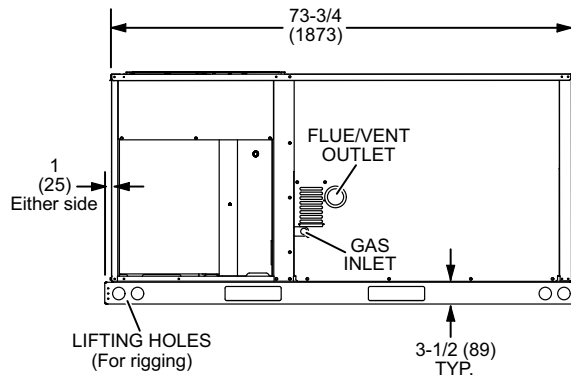

**FRONT VIEW**

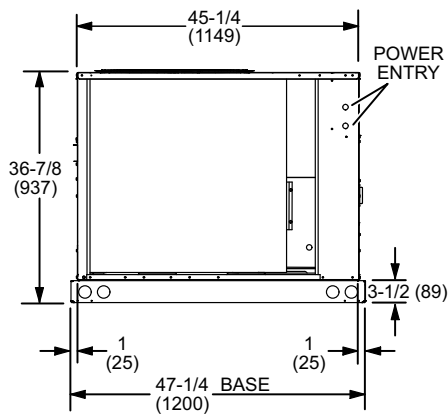

**END VIEW**

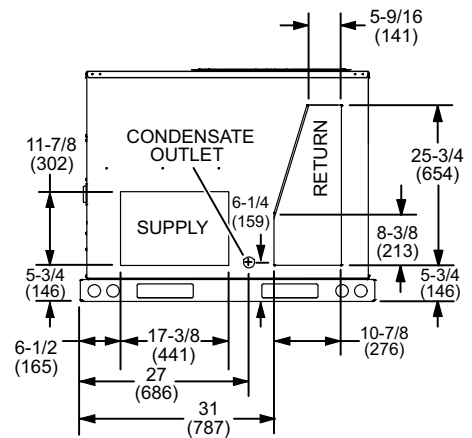

**END VIEW**

**ZGA036, 048, 060 PARTS ARRANGEMENT**

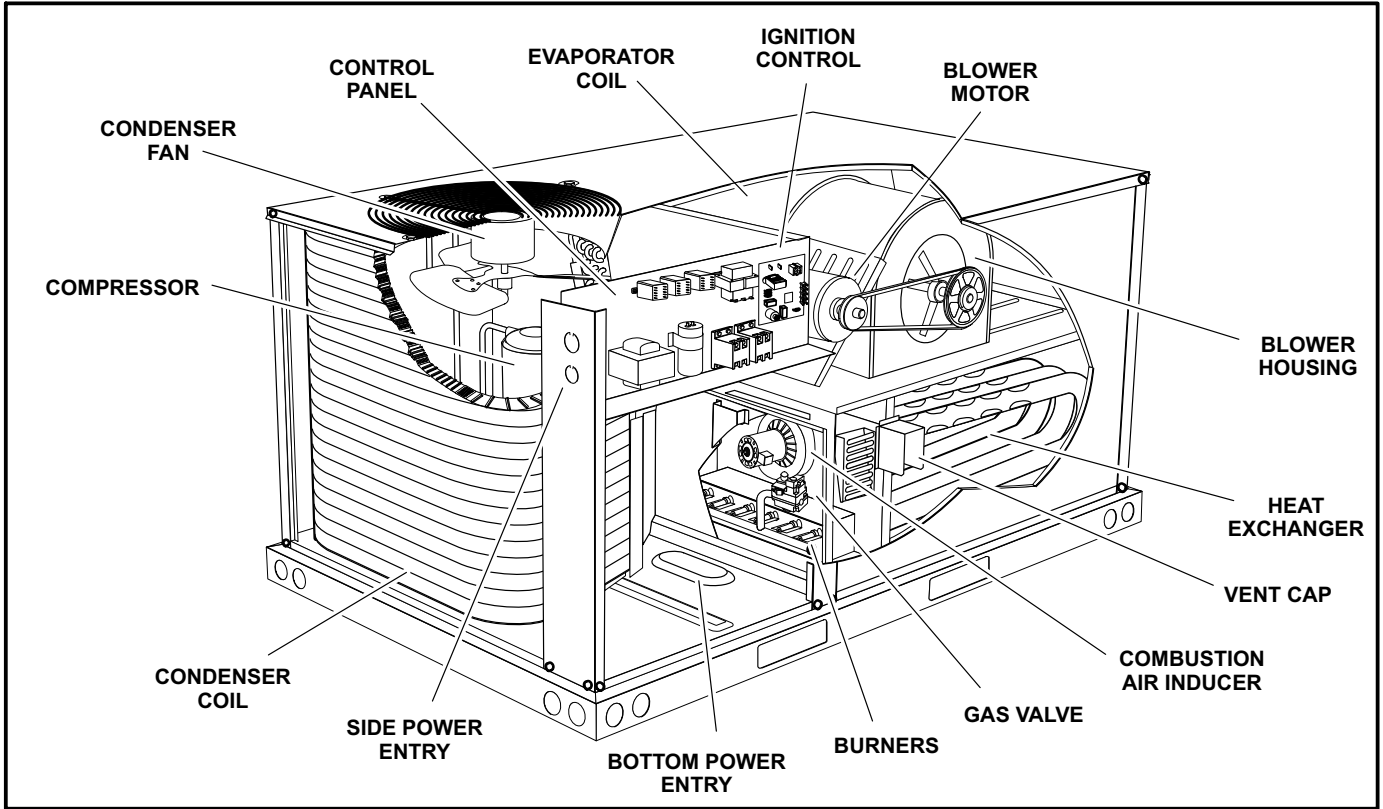

**ZCA036, 048, 060 PARTS ARRANGEMENT**

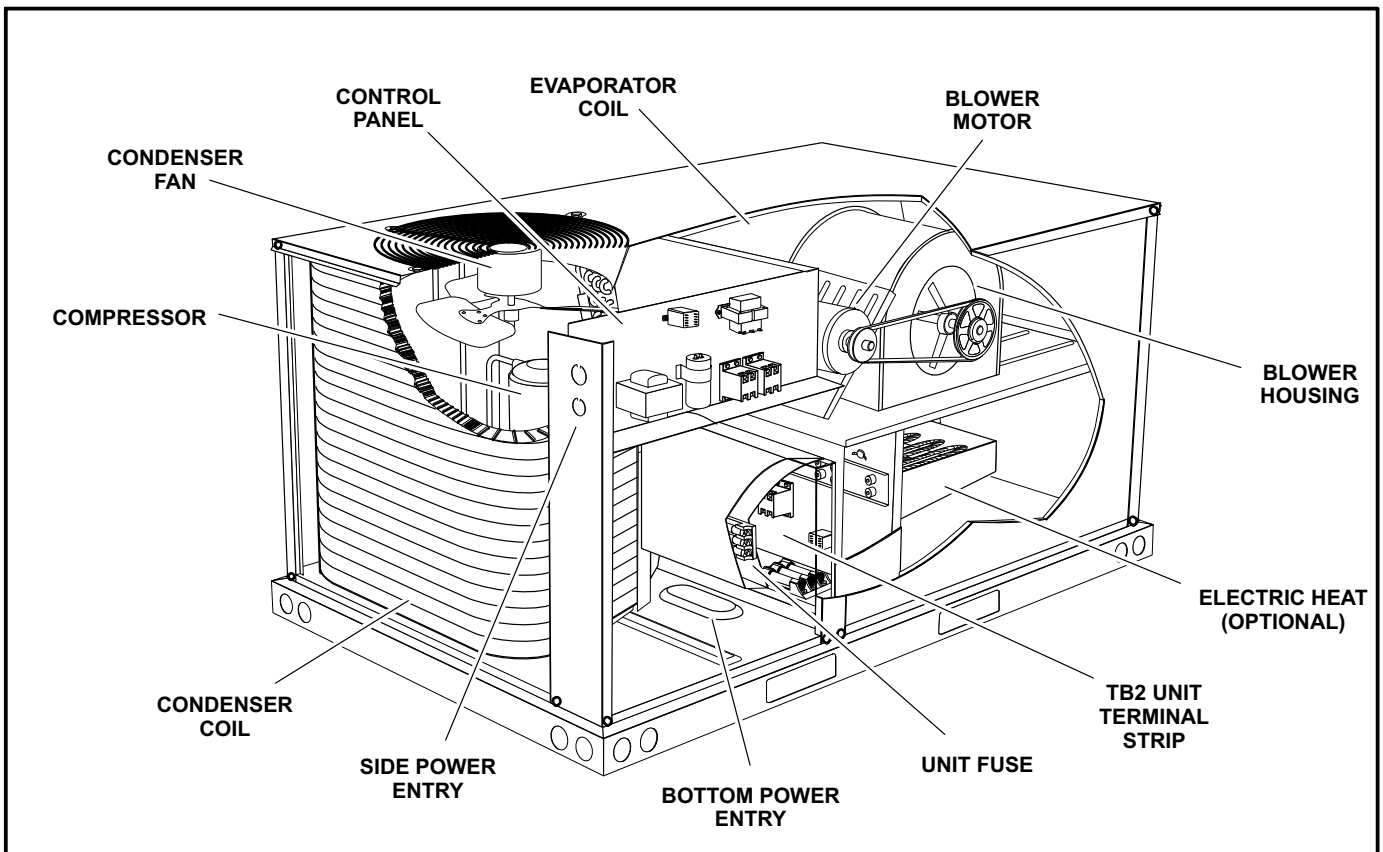

## Shipping and Packing List

### Package 1 of 1 contains:

1- Assembled unit

Check unit for shipping damage. Receiving party should contact last carrier immediately if shipping damage is found.

## General

These instructions are intended as a general guide and do not supersede local codes in any way. Authorities having jurisdiction should be consulted before installation.

The ZG units are available in three heating inputs. The ZC cooling packaged rooftop unit is the same basic design as the ZG unit except for the heating section. Optional electric heat is available for ZC units. ZG and ZC units have identical refrigerant circuits with respective 3-, 4- and 5-ton cooling capacities.

Availability of units and options varies by brand.

## Requirements

See figure 1 for unit clearances.

### ⚠ NOTICE

**Roof Damage!**  
 This system contains both refrigerant and oil. Some rubber roofing material may absorb oil, causing the rubber to swell. Bubbles in the rubber roofing material can cause leaks. Protect the roof surface to avoid exposure to refrigerant and oil during service and installation. Failure to follow this notice could result in damage to roof surface.

### ⚠ WARNING

**Electric shock hazard and danger of explosion. Can cause injury, death or product or property damage. Turn off gas and electrical power to unit before performing any maintenance or servicing operations on the unit. Follow lighting instructions attached to unit when putting unit back into operation and after service or maintenance.**

### ⚠ IMPORTANT

**The Clean Air Act of 1990 bans the intentional venting of refrigerant (CFC's and HCFC's) as of July 1, 1992. Approved methods of recovery, recycling or reclaiming must be followed. Fines and/or incarceration may be levied for non-compliance.**

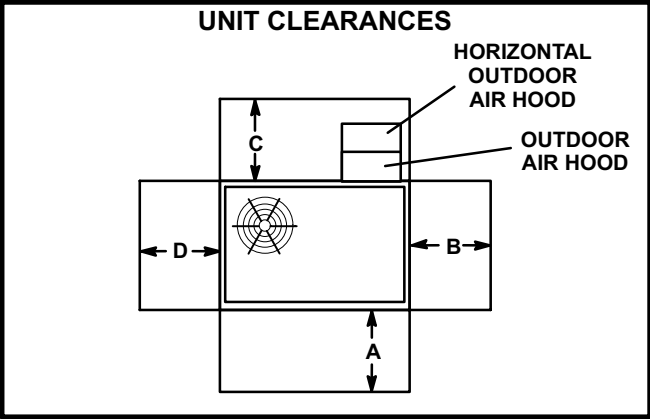

FIGURE 1

<sup>1</sup> Unit Clearance	A in.(mm)	B in.(mm)	C in.(mm)	D in.(mm)	Top Clearance
Service Clearance	36 (914)	36 (914)	36* (914)	36 (914)	Unob- structed
Clearance to Combustibles	36 (914)	1 (25)	1 (25)	1 (25)	Unob- structed
Minimum Operation Clearance	36 (914)	36 (914)	36* (914)	36 (914)	Unob- structed

\*Clearance is 60 in. (1524mm) in horizontal air flow applications.  
 Note - Entire perimeter of unit base requires support when elevated above mounting surface.

<sup>1</sup> **Service Clearance** - Required for removal of serviceable parts.  
**Clearance to Combustibles** - Required clearance to combustible material (gas units).  
**Minimum Operation Clearance** - Required clearance for proper unit operation.

Use of this unit as a construction heater or air conditioner is not recommended during any phase of construction. Very low return air temperatures, harmful vapors and operation of the unit with clogged or misplaced filters will damage the unit.

If this unit has been used for heating or cooling of buildings or structures under construction, the following conditions must be met or the warranty will be void:

- A room thermostat must control the unit. The use of fixed jumpers that will provide continuous heating or cooling is not allowed.
- A pre-filter must be installed at the entry to the return air duct.
- The return air duct must be provided and sealed to the unit.
- Return air temperature range between 55°F (13°C) and 80°F (27°C) must be maintained.
- Air filters must be replaced and pre-filters must be removed upon construction completion.
- The input rate and temperature rise must be set per the unit rating plate.
- The heat exchanger, components, duct system, air filters and evaporator coil must be thoroughly cleaned following final construction clean-up.

- The unit operating conditions (including airflow, cooling operation, ignition, input rate, temperature rise and venting) must be verified according to these installation instructions.

## Unit Support

In downflow discharge installations, install the unit on a non-combustible surface only. Unit may be installed on combustible surfaces when used in horizontal discharge applications or in downflow discharge applications when installed on a Z1CURB roof mounting frame.

*NOTE - Securely fasten roof frame to roof per local codes.*

### A-Downflow Discharge Application

#### Roof Mounting with Z1CURB

- 1- The Z1CURB roof mounting frame must be installed, flashed and sealed in accordance with the instructions provided with the frame.
- 2- The Z1CURB roof mounting frame should be square and level to 1/16" per linear foot (5mm per linear meter) in any direction.
- 3- Duct must be attached to the roof mounting frame and not to the unit; supply and return plenums must be installed before setting the unit.

#### Installer's Roof Mounting Frame

Many types of roof frames can be used to install the unit depending upon different roof structures. Items to keep in mind when using the building frame or supports are:

- 1- The base is fully enclosed and not insulated, so an enclosed, insulated frame is required.
- 2- The frames or supports must be constructed with non-combustible materials and should be square and level to 1/16" per linear foot (5mm per linear meter) in any direction.
- 3- Frame or supports must be high enough to prevent any form of moisture from entering unit. Recommended minimum frame height is 14" (356mm).
- 4- Duct must be attached to the roof mounting frame and not to the unit. Supply and return plenums must be installed before setting the unit.
- 5- Units require support along all four sides of unit base. Supports must be constructed of steel or suitably treated wood materials.

*NOTE-When installing a unit on a combustible surface for downflow discharge applications, a Z1CURB roof mounting frame is required.*

### B-Horizontal Discharge Applications

- 1- Specified installation clearances must be maintained when installing units. Refer to figure 1.
- 2- Top of support slab should be approximately 4" (102mm) above the finished grade and located so no

run-off water from higher ground can collect around the unit.

- 3- Units require support along all four sides of unit base. Supports must be constructed of steel or suitably treated wood materials.

## Duct Connection

All exterior ducts, joints and openings in roof or building walls must be insulated and weather-proofed with flashing and sealing compounds in accordance with applicable codes. Any duct passing through an unconditioned space must be insulated.

## ⚠ CAUTION

**In downflow applications, do not drill or punch holes in base of unit. Leaking in roof may occur if unit base is punctured.**

## Rigging Unit For Lifting

Rig unit for lifting by attaching four cables to holes in unit base rail. See figure 2.

- 1- Connect rigging to the unit base using both holes in each corner.
- 2- All panels must be in place for rigging.
- 3- Place field-provided H-style pick in place just above top edge of unit. Frame must be of adequate strength and length. (H-style pick prevents damage to unit.)

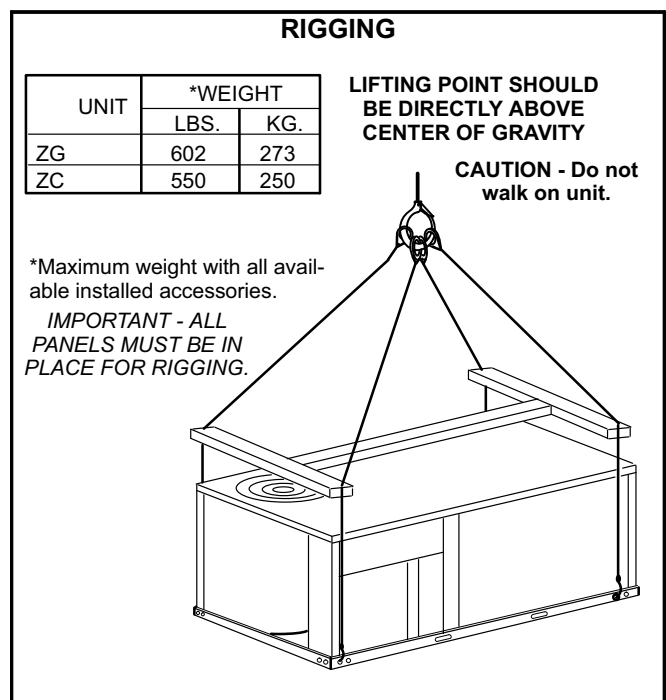

**FIGURE 2**

## Horizontal Air Discharge

Unit is shipped with panels covering the horizontal supply and return air openings. See figure 3.

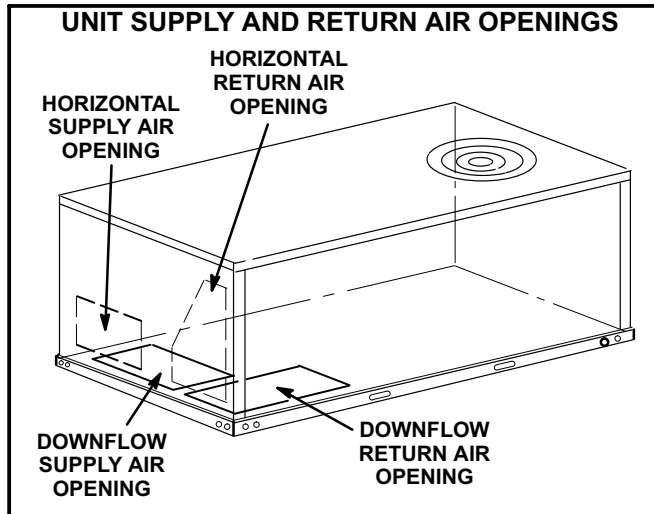

FIGURE 3

- 1- Remove horizontal covers and place a bead of silicone sealant on the underside of the duct cover flanges. See figure 4.
- 2- Position covers over downflow openings. Secure covers with self-drilling screws in at least two places on each cover. Drill through duct cover side into flange of base pan.
- 3- Place a bead of silicone between insulation and duct cover to seal in insulation edges. Let silicone dry before running gas or electric heat.

Units Equipped With An Optional Horizontal Economizer

- 1- Install the horizontal supply air cover over the down flow supply air opening as described above.
- 2- Leave the horizontal return air cover in place.
- 3- Locate the extra horizontal return cover that is included with the horizontal economizer kit. Install as described in previous section.

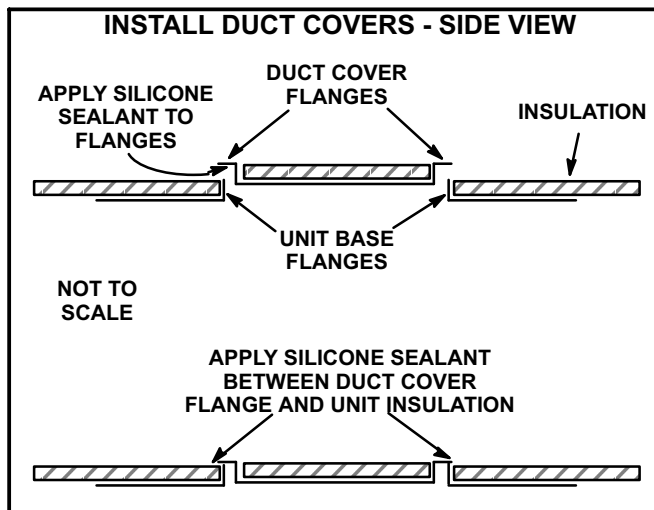

FIGURE 4

- 4- Install return air duct on the intake air side of the horizontal economizer. See figure 5.
- 5- Horizontal economizer and return air duct must be field-supported.

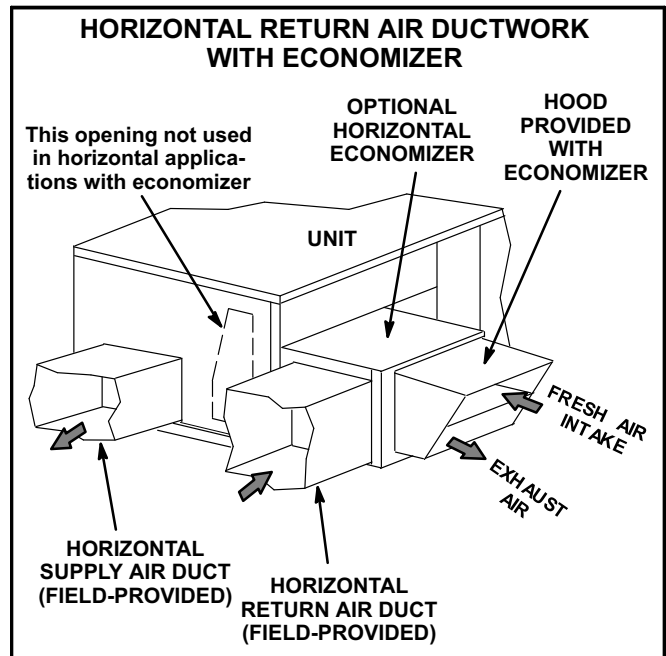

FIGURE 5

## Condensate Drains

Make drain connection to the 1" N.P.T. drain coupling provided on unit.

*Note - The drain pan is made with a glass reinforced engineered plastic capable of withstanding typical joint torque but can be damaged with excessive force. Tighten pipe nipple hand tight and turn an additional quarter turn.*

A trap must be installed between drain connection and an open vent for proper condensate removal. See figure 6. It is sometimes acceptable to drain condensate onto the roof or grade; however, a tee should be fitted to the trap to direct condensate downward. The condensate line must be vented. Check local codes concerning condensate disposal. Refer to page 2 for condensate drain location.

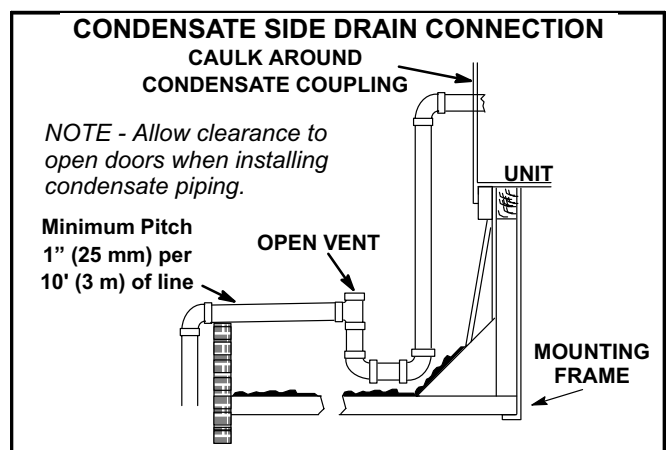

FIGURE 6

## Connect Gas Piping (Gas Units)

Before connecting field-provided piping, check with gas company or authorities having jurisdiction for local code requirements. When installing gas supply piping, length of run from gas meter must be considered in determining pipe size for 0.5" w.c. (.12kPa) maximum pressure drop. Do not use supply pipe smaller than unit gas connection. Operating pressures at the unit gas connection must be as shown in table 1.

**TABLE 1  
OPERATING PRESSURE AT GAS CONNECTION "w.c."**

	Natural Gas		LP / Propane Gas	
	Min.	Max.	Min.	Max.
036-060	4.5	10.5	11	13

When making piping connections a drip leg should be installed on vertical pipe runs to serve as a trap for sediment or condensate. A 1/8" N.P.T. plugged tap is located on gas valve for test gauge connection. Refer to Heating Start-Up section for tap location. Install a ground joint union between the gas control manifold and the main manual shut-off valve. See figure 7 for gas supply piping entering outside the unit.

Compounds used on threaded joints of gas piping shall be resistant to the action of liquified petroleum gases.

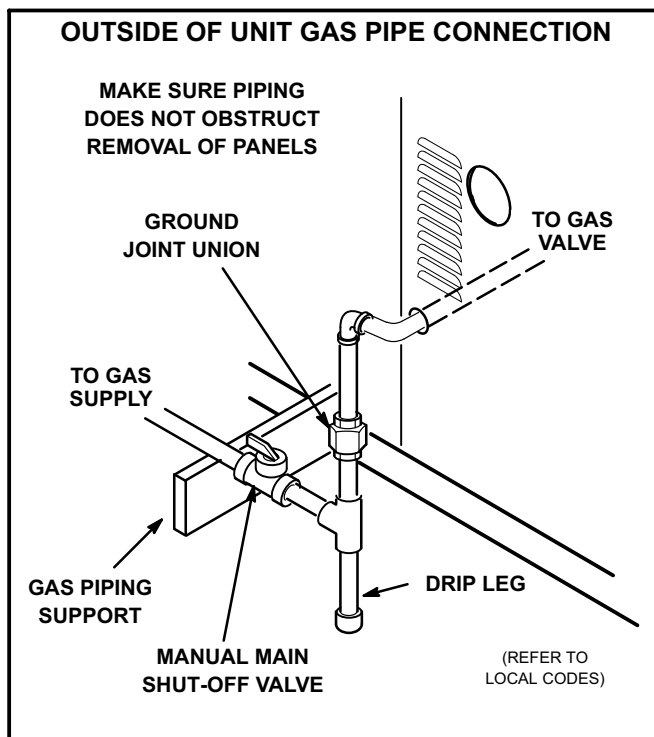

**FIGURE 7**

## Pressure Test Gas Piping (Gas Units)

When pressure testing gas lines, the gas valve must be disconnected and isolated. Gas valves can be damaged if subjected to more than 0.5 psig (3.48kPa). See figure 8.

*NOTE-Codes may require that manual main shut-off valve and union (furnished by installer) be installed in gas line external to unit. Union must be of the ground joint type.*

After all connections have been made, check all piping connections for gas leaks. Also check existing unit gas connections up to the gas valve; loosening may occur during installation. Use a leak detection solution or other preferred means. Do not use matches candles or other sources of ignition to check for gas leaks.

### ⚠ CAUTION

Some soaps used for leak detection are corrosive to certain metals. Carefully rinse piping thoroughly after leak test has been completed. Do not use matches, candles, flame or other sources of ignition to check for gas leaks.

### ⚠ WARNING



Danger of explosion. Can cause injury or product or property damage. Do not use matches, candles, flame or other sources of ignition to check for leaks.

*NOTE-In case emergency shut down is required, turn off the main manual shut-off valve and disconnect main power to unit. These devices should be properly labeled by the installer.*

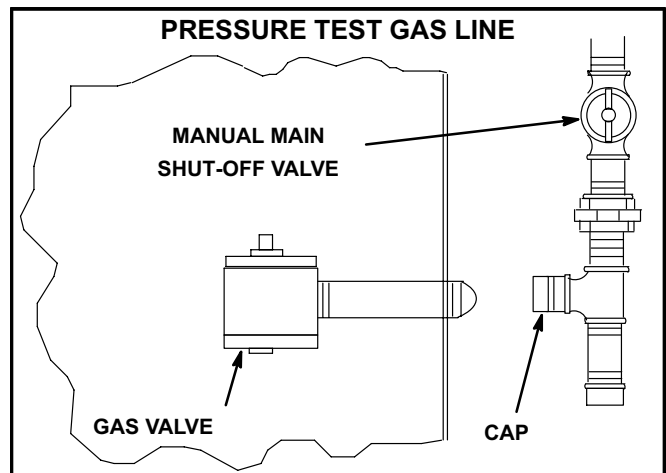

**FIGURE 8**

## Install Vent Cap

Remove the vent cap from the shipping location and use existing screws to install the vent cap over the flue outlet. See figure 9. The installed vent cap is shown in the Parts Arrangement in the front of this manual.

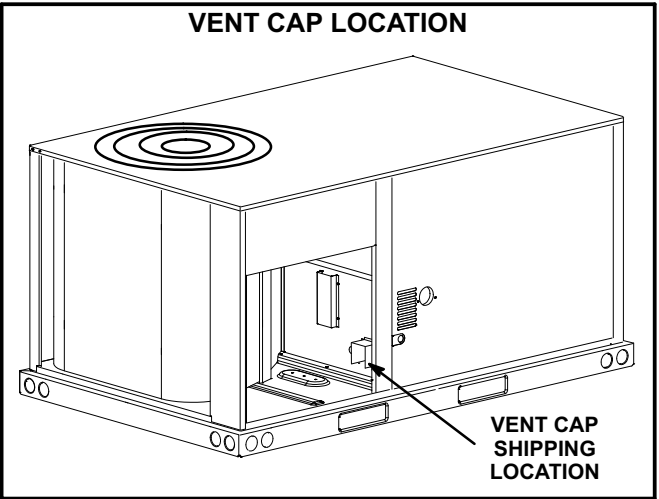

**FIGURE 9**

## High Altitude Derate

Locate the high conversion sticker in the unit literature bag. Fill out the conversion sticker and affix next to the unit nameplate.

Refer to table 2 for high altitude adjustments.

**TABLE 2  
HIGH ALTITUDE DERATE**

Altitude Ft.*	Gas Manifold Pressure
2000-4500	See Unit Nameplate
4500 And Above	Derate 2% / 1000 Ft. Above Sea Level

\*Units installed at 0-2000 feet do not need to be modified.

*NOTE - This is the only permissible derate for these units.*

## Electrical Connections

### POWER SUPPLY

Do not apply power or close disconnect switch until installation is complete. Refer to start-up directions. Refer closely to unit wiring diagram.

Refer to unit nameplate for minimum circuit ampacity and maximum fuse size.

- 1- Units are factory-wired for 230,460,575 volt supply. **For 208V supply**, remove the insulated terminal cover from the 208V terminal on the control transformer. Move the wire from the transformer

240V terminal to the 208V terminal. Place the insulated terminal cover on the unused 240V terminal.

- 2- Route power through the side or bottom power entry area. For bottom power entry, a bottom power entry kit must be used. Connect power wiring to power wiring leads in the control box. On ZC units equipped with electric heat, route power wiring to TB2; see parts arrangement for location. See unit wiring diagram.

### CONTROL WIRING

#### A-Thermostat Location

Room thermostat mounts vertically on a standard 2" X 4" handy box or on any non-conductive flat surface.

Locate thermostat approximately 5 feet (1524mm) above the floor in an area with good air circulation at average temperature. Avoid locating the room thermostat where it might be affected by:

- drafts or dead spots behind doors and in corners
- hot or cold air from ducts
- radiant heat from sun or appliances
- concealed pipes and chimneys

#### B-Control Wiring

- 1- Route thermostat cable or wires from subbase to control panel (refer to unit dimensions to locate bottom and side power entry).

*IMPORTANT - Unless field thermostat wires are rated for maximum unit voltage, they must be routed away from line voltage wiring.*

Use 18 AWG wire for all applications using remotely installed electro-mechanical and electronic thermostats.

- 2- Install thermostat assembly in accordance with instructions provided with thermostat.
- 3- Connect thermostat wiring to leads in control panel. Wire as shown in figure 10 for electro-mechanical and electronic thermostats. If using other temperature control devices or energy management systems see instructions and wiring diagram provided by manufacturer.

*IMPORTANT-Terminal connections at the wall plate or subbase must be made securely. Loose control wire connections may allow unit to operate but not with proper response to room demand.*



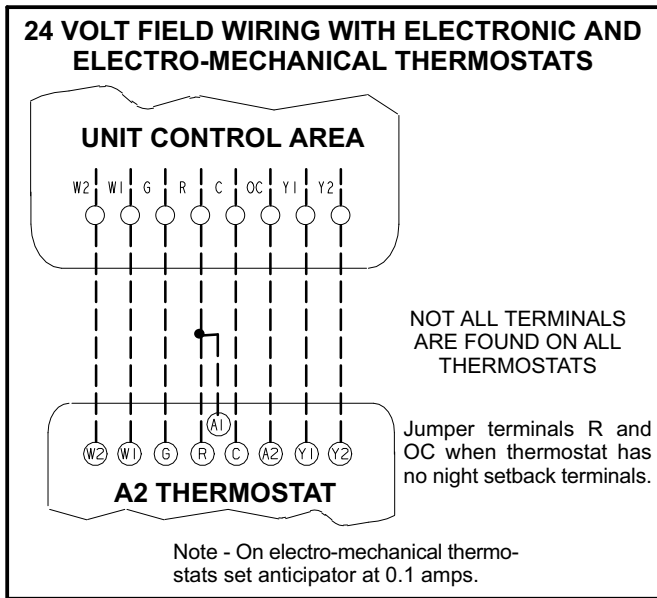

**FIGURE 10**

**Blower Operation and Adjustments**

**⚠ IMPORTANT**

Three phase scroll compressors must be phased sequentially for correct compressor and blower rotation. Follow "COOLING START-UP" section of installation instructions to ensure proper compressor and blower operation.

**A-Blower Operation**

Initiate blower demand at thermostat according to instructions provided with thermostat. Unit will cycle on thermostat demand. The following steps apply to applications using a typical electro-mechanical thermostat.

1- Blower operation is manually set at the thermostat subbase fan switch. With fan switch in **ON** position, blowers will operate continuously.

2- With fan switch in **AUTO** position, the blowers will cycle with demand. Blowers and entire unit will be off when system switch is in **OFF** position.

**B-Determining Unit CFM - Belt Drive Blowers**

1- The following measurements must be made with air filters in place.

2- With all access panels in place, measure static pressure external to unit (from supply to return). Blower performance data is based on static pressure readings taken in locations shown in figure 11.

*Note - Static pressure readings can vary if not taken where shown.*

3- Referring to pages 11 through 16, use static pressure and RPM readings to determine unit CFM. Use page 17 when installing units with any of the options or accessories listed. Refer to table 5 for minimum airflow when electric heat is installed.

4- The blower RPM can be adjusted at the motor pulley. Loosen Allen screw and turn adjustable pulley clockwise to increase CFM. Turn counterclockwise to decrease CFM. See figure 12. Do not exceed minimum and maximum number of pulley turns as shown in table 3.

**TABLE 3  
MINIMUM AND MAXIMUM PULLEY ADJUSTMENT**

Belt	Min. Turns Open	Maxi. Turns Open
A Section	No minimum	5

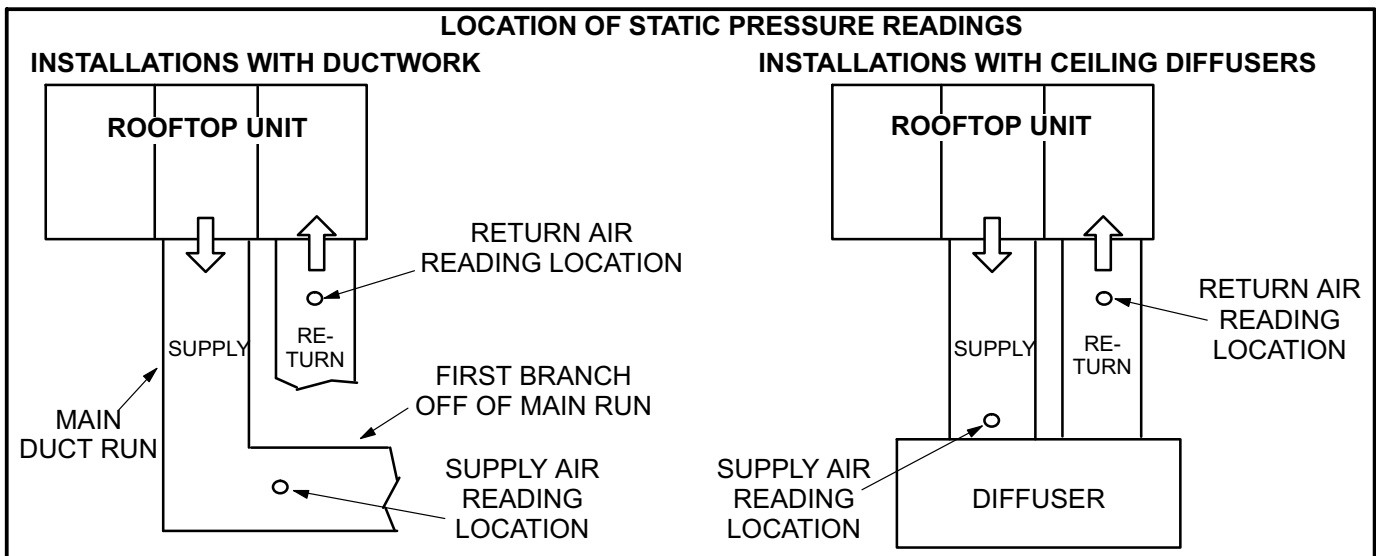

**FIGURE 11**

## BLOWER ASSEMBLY

### TO INCREASE BELT TENSION

- 1-Loosen four bolts securing motor base to mounting frame.
- 2-Slide the motor downward to tighten the belt.
- 3-Tighten four bolts on motor base.

### SIDE VIEW

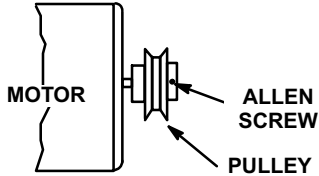

LOOSEN FOUR BOLTS AND SLIDE BLOWER MOTOR DOWNWARD TO TIGHTEN BELT

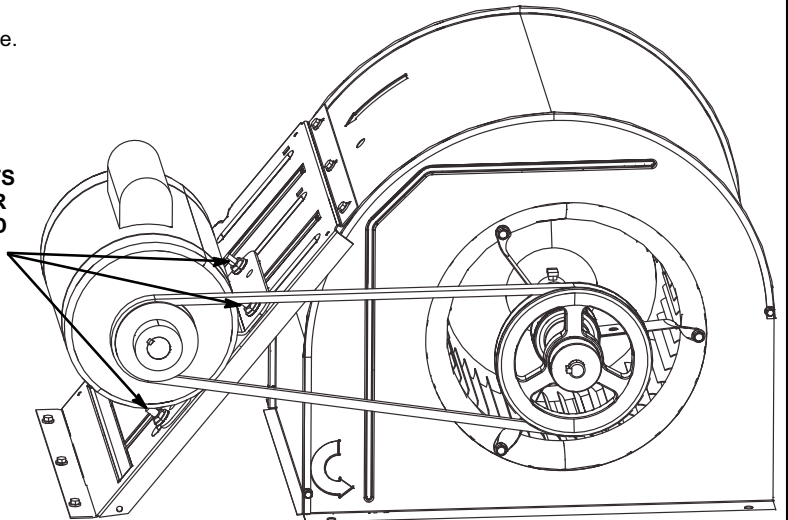

**TO INCREASE CFM**  
LOOSEN ALLEN SCREW &  
TURN PULLEY CLOCKWISE

**TO DECREASE CFM**  
TURN PULLEY  
COUNTERCLOCKWISE

FIGURE 12

### C-Blower Belt Adjustment

Maximum life and wear can be obtained from belts only if proper pulley alignment and belt tension are maintained. Tension new belts after a 24-48 hour period of operation. This will allow belt to stretch and seat into grooves. Make sure blower and motor pulley are aligned as shown in figure 13.

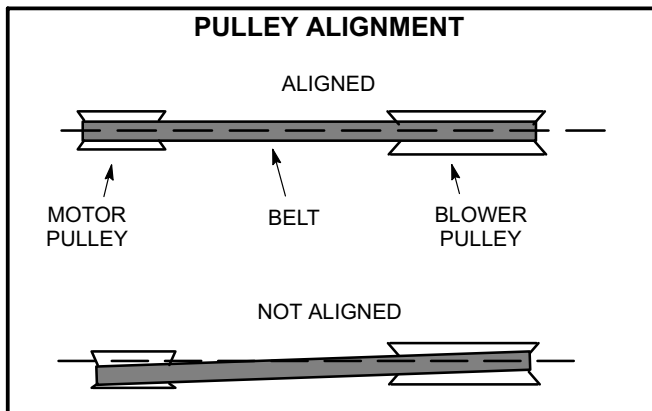

FIGURE 13

- 1- Loosen four bolts securing motor base to mounting frame. See figure 12.
- 2- *To increase belt tension* - Slide blower motor downward to tighten the belt. This increases the distance between the blower motor and the blower housing.
- 3- *To loosen belt tension* - Slide blower motor upward to loosen the belt. This decreases the distance between the blower motor and the blower housing.
- 4- Tighten four bolts securing motor base to the mounting frame.

### D-Check Belt Tension

Overtensioning belts shortens belt and bearing life. Check belt tension as follows:

- 1- Measure span length X. See figure 14.

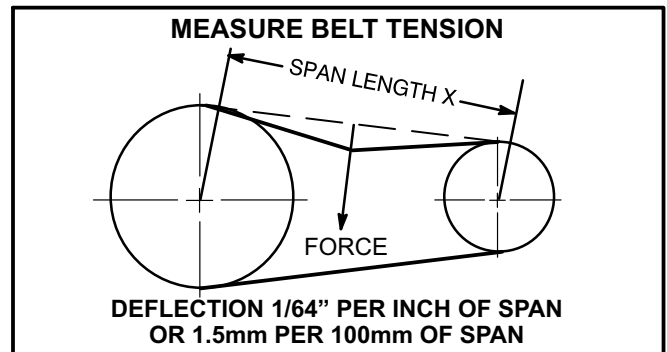

FIGURE 14

- 2- Apply perpendicular force to center of span (X) with enough pressure to deflect belt  $1/64$ " for every inch of span length or 1.5mm per 100mm of span length. Example: Deflection distance of a 40" span would be  $40/64$ " or  $5/8$ ". Example: Deflection distance of a 400mm span would be 6mm.
- 3- Measure belt deflection force. For a used belt, the deflection force should be 5 lbs. (35kPa). A new belt deflection force should be 7 lbs. (48kPa). A force below these values indicates an undertensioned belt. A force above these values indicates an overtensioned belt.

### E-Field-Furnished Blower Drives

For field-furnished blower drives, use pages 11 through 16 to determine BHP and RPM required. Reference page 17 for additional air resistance and to determine the drive kit number. See table 4 for drive component manufacturers numbers.

## BLOWER DATA - BELT DRIVE - ZGA036

**BLOWER TABLE INCLUDES RESISTANCE FOR BASE UNIT ONLY WITH DRY INDOOR COIL AND AIR FILTERS IN PLACE.**

FOR ALL UNITS ADD:

1 - Any factory installed options air resistance (heat section, economizer, wet coil, etc.).

2 - Any field installed accessories air resistance (duct resistance, diffuser, etc.).

See page 17 for blower motors and drives and wet coil and options/accessory air resistance data.

### DOWNFLOW

Air Volume cfm	External Static - in. w.g.															
	0.10		0.20		0.30		0.40		0.50		0.60		0.70		0.80	
	RPM	BHP	RPM	BHP	RPM	BHP	RPM	BHP	RPM	BHP	RPM	BHP	RPM	BHP	RPM	BHP
	Field Furnished				Kit Z01											
900	566	0.16	631	0.18	699	0.19	768	0.21	836	0.22	901	0.25	961	0.27	1016	0.29
1000	591	0.18	656	0.20	724	0.21	793	0.23	859	0.25	922	0.27	979	0.30	1032	0.33
1100	618	0.20	684	0.22	752	0.24	819	0.26	883	0.28	944	0.31	998	0.34	1049	0.37
1200	648	0.23	715	0.25	782	0.27	847	0.29	910	0.32	967	0.35	1020	0.38	1068	0.42
1300	681	0.26	748	0.28	814	0.30	878	0.33	937	0.36	992	0.39	1043	0.43	1089	0.47
1400	718	0.29	783	0.32	848	0.34	909	0.37	966	0.41	1018	0.44	1067	0.48	1112	0.52
1500	757	0.33	821	0.36	883	0.39	941	0.42	995	0.46	1046	0.50	1092	0.54	1136	0.57

Air Volume cfm	External Static - in. w.g.															
	0.90		1.00		1.10		1.20		1.30		1.40		1.50		1.60	
	RPM	BHP	RPM	BHP	RPM	BHP	RPM	BHP	RPM	BHP	RPM	BHP	RPM	BHP	RPM	BHP
	Kit Z04															
900	1067	0.32	1115	0.35	1161	0.37	1205	0.40	1247	0.43	1287	0.47	1326	0.50	1365	0.53
1000	1081	0.36	1128	0.39	1173	0.41	1216	0.44	1258	0.48	1297	0.51	1336	0.54	1374	0.58
1100	1097	0.40	1143	0.43	1187	0.46	1229	0.49	1270	0.52	1309	0.56	1347	0.59	1384	0.63
1200	1115	0.45	1159	0.48	1202	0.51	1244	0.54	1284	0.58	1323	0.61	1360	0.65	1397	0.69
1300	1134	0.50	1177	0.53	1219	0.56	1260	0.60	1300	0.63	1338	0.67	1375	0.71	1411	0.75
1400	1155	0.55	1197	0.59	1238	0.62	1278	0.66	1317	0.70	1354	0.74	1391	0.78	1426	0.82
1500	1177	0.61	1218	0.65	1258	0.68	1298	0.72	1336	0.76	1373	0.81	1409	0.85	1443	0.89

### HORIZONTAL

Air Volume cfm	External Static - in. w.g.															
	0.10		0.20		0.30		0.40		0.50		0.60		0.70		0.80	
	RPM	BHP	RPM	BHP	RPM	BHP	RPM	BHP	RPM	BHP	RPM	BHP	RPM	BHP	RPM	BHP
	Field Furnished				Kit Z01											
900	566	0.13	634	0.16	704	0.18	773	0.20	839	0.23	902	0.25	961	0.28	1016	0.31
1000	590	0.16	658	0.18	728	0.20	795	0.23	860	0.25	920	0.28	977	0.31	1030	0.34
1100	615	0.18	685	0.20	754	0.23	820	0.26	883	0.29	941	0.32	995	0.35	1046	0.38
1200	644	0.21	714	0.23	782	0.26	847	0.29	908	0.33	963	0.36	1015	0.39	1064	0.42
1300	676	0.24	746	0.27	814	0.30	876	0.33	934	0.37	987	0.41	1037	0.44	1083	0.47
1400	713	0.28	782	0.31	847	0.35	907	0.38	962	0.42	1013	0.45	1060	0.49	1105	0.52
1500	755	0.33	821	0.36	883	0.39	939	0.43	991	0.47	1039	0.50	1085	0.54	1128	0.57

Air Volume cfm	External Static - in. w.g.															
	0.90		1.00		1.10		1.20		1.30		1.40		1.50		1.60	
	RPM	BHP	RPM	BHP	RPM	BHP	RPM	BHP	RPM	BHP	RPM	BHP	RPM	BHP	RPM	BHP
	Kit Z04															
900	1068	0.33	1118	0.36	1165	0.38	1211	0.41	1254	0.44	1294	0.47	1332	0.50	1369	0.54
1000	1080	0.37	1128	0.39	1175	0.42	1219	0.45	1262	0.48	1302	0.51	1340	0.55	1377	0.58
1100	1094	0.41	1141	0.43	1186	0.46	1230	0.49	1272	0.52	1311	0.56	1349	0.60	1386	0.64
1200	1110	0.45	1155	0.48	1200	0.51	1243	0.54	1284	0.58	1323	0.61	1361	0.66	1398	0.70
1300	1128	0.50	1172	0.53	1215	0.56	1258	0.59	1298	0.63	1337	0.67	1375	0.72	1411	0.76
1400	1148	0.55	1191	0.58	1233	0.62	1274	0.65	1314	0.69	1353	0.74	1391	0.79	1427	0.83
1500	1170	0.61	1211	0.64	1252	0.68	1293	0.72	1333	0.76	1371	0.81	1408	0.86	1444	0.91

## BLOWER DATA - BELT DRIVE - ZGA048

**BLOWER TABLE INCLUDES RESISTANCE FOR BASE UNIT ONLY WITH DRY INDOOR COIL AND AIR FILTERS IN PLACE.**

FOR ALL UNITS ADD:

1 - Any factory installed options air resistance (heat section, economizer, wet coil, etc.).

2 - Any field installed accessories air resistance (duct resistance, diffuser, etc.).

See page 17 for blower motors and drives and wet coil and options/accessory air resistance data.

### DOWNFLOW

Air Volume cfm	External Static - in. w.g.															
	0.10		0.20		0.30		0.40		0.50		0.60		0.70		0.80	
	RPM	BHP	RPM	BHP	RPM	BHP	RPM	BHP	RPM	BHP	RPM	BHP	RPM	BHP	RPM	BHP
	Field Furnished						Kit Z02									
1200	648	0.23	715	0.25	782	0.27	847	0.29	910	0.32	967	0.35	1020	0.38	1068	0.42
1300	681	0.26	748	0.28	814	0.30	878	0.33	937	0.36	992	0.39	1043	0.43	1089	0.47
1400	718	0.29	783	0.32	848	0.34	909	0.37	966	0.41	1018	0.44	1067	0.48	1112	0.52
1500	757	0.33	821	0.36	883	0.39	941	0.42	995	0.46	1046	0.50	1092	0.54	1136	0.57
1600	798	0.38	860	0.41	919	0.44	974	0.47	1026	0.51	1074	0.55	1119	0.59	1161	0.63
1700	840	0.43	899	0.46	955	0.49	1007	0.53	1057	0.57	1103	0.61	1146	0.66	1187	0.70
1800	882	0.48	938	0.51	991	0.55	1041	0.59	1088	0.63	1132	0.68	1174	0.72	1214	0.77
1900	924	0.54	977	0.58	1027	0.62	1075	0.66	1120	0.70	1163	0.75	1203	0.80	1242	0.85
2000	965	0.61	1016	0.65	1064	0.69	1110	0.74	1153	0.79	1194	0.84	1233	0.89	1271	0.95

Air Volume cfm	External Static - in. w.g.															
	0.90		1.00		1.10		1.20		1.30		1.40		1.50		1.60	
	RPM	BHP	RPM	BHP	RPM	BHP	RPM	BHP	RPM	BHP	RPM	BHP	RPM	BHP	RPM	BHP
	Kit Z02						Kit Z05									
1200	1115	0.45	1159	0.48	1202	0.51	1244	0.54	1284	0.58	1323	0.61	1360	0.65	1397	0.69
1300	1134	0.50	1177	0.53	1219	0.56	1260	0.60	1300	0.63	1338	0.67	1375	0.71	1411	0.75
1400	1155	0.55	1197	0.59	1238	0.62	1278	0.66	1317	0.70	1354	0.74	1391	0.78	1426	0.82
1500	1177	0.61	1218	0.65	1258	0.68	1298	0.72	1336	0.76	1373	0.81	1409	0.85	1443	0.89
1600	1201	0.68	1241	0.71	1280	0.75	1319	0.80	1357	0.84	1393	0.88	1428	0.93	1462	0.97
1700	1226	0.74	1265	0.79	1304	0.83	1342	0.87	1378	0.92	1414	0.96	1448	1.01	1482	1.05
1800	1253	0.82	1291	0.87	1329	0.91	1366	0.96	1402	1.01	1436	1.05	1469	1.10	1502	1.14
1900	1280	0.90	1318	0.95	1355	1.00	1391	1.05	1426	1.10	1459	1.15	1492	1.20	1524	1.24
2000	1309	1.00	1346	1.05	1382	1.10	1417	1.16	1451	1.21	1484	1.25	1515	1.30	1547	1.35

### HORIZONTAL

Air Volume cfm	External Static - in. w.g.															
	0.10		0.20		0.30		0.40		0.50		0.60		0.70		0.80	
	RPM	BHP	RPM	BHP	RPM	BHP	RPM	BHP	RPM	BHP	RPM	BHP	RPM	BHP	RPM	BHP
	Field Furnished						Kit Z02									
1200	644	0.21	714	0.23	782	0.26	847	0.29	908	0.33	963	0.36	1015	0.39	1064	0.42
1300	676	0.24	746	0.27	814	0.3	876	0.33	934	0.37	987	0.41	1037	0.44	1083	0.47
1400	713	0.28	782	0.31	847	0.35	907	0.38	962	0.42	1013	0.45	1060	0.49	1105	0.52
1500	755	0.33	821	0.36	883	0.39	939	0.43	991	0.47	1039	0.5	1085	0.54	1128	0.57
1600	798	0.38	860	0.41	918	0.45	971	0.48	1020	0.52	1067	0.55	1110	0.59	1152	0.63
1700	842	0.43	900	0.47	954	0.5	1004	0.54	1051	0.57	1095	0.61	1137	0.65	1177	0.69
1800	885	0.49	940	0.53	990	0.56	1037	0.6	1081	0.63	1124	0.67	1164	0.72	1204	0.76
1900	928	0.56	979	0.59	1026	0.63	1070	0.67	1113	0.71	1153	0.75	1193	0.79	1231	0.84
2000	969	0.63	1017	0.67	1062	0.7	1104	0.74	1145	0.79	1184	0.83	1222	0.88	1259	0.94

Air Volume cfm	External Static - in. w.g.															
	0.90		1.00		1.10		1.20		1.30		1.40		1.50		1.60	
	RPM	BHP	RPM	BHP	RPM	BHP	RPM	BHP	RPM	BHP	RPM	BHP	RPM	BHP	RPM	BHP
	Kit Z02						Kit Z05									
1200	1110	0.45	1155	0.48	1200	0.51	1243	0.54	1284	0.58	1323	0.61	1361	0.66	1398	0.7
1300	1128	0.5	1172	0.53	1215	0.56	1258	0.59	1298	0.63	1337	0.67	1375	0.72	1411	0.76
1400	1148	0.55	1191	0.58	1233	0.62	1274	0.65	1314	0.69	1353	0.74	1391	0.79	1427	0.83
1500	1170	0.61	1211	0.64	1252	0.68	1293	0.72	1333	0.76	1371	0.81	1408	0.86	1444	0.91
1600	1193	0.67	1233	0.71	1273	0.75	1313	0.79	1352	0.84	1390	0.89	1427	0.94	1463	1
1700	1217	0.73	1256	0.78	1296	0.82	1335	0.87	1374	0.93	1411	0.98	1447	1.03	1482	1.09
1800	1242	0.81	1281	0.86	1320	0.91	1359	0.96	1396	1.02	1433	1.07	1468	1.13	1503	1.18
1900	1269	0.9	1307	0.95	1346	1.01	1383	1.06	1420	1.12	1456	1.18	1491	1.23	1525	1.29
2000	1297	0.99	1334	1.05	1372	1.11	1409	1.17	1445	1.23	1480	1.29	1514	1.34	1547	1.4

## BLOWER DATA - BELT DRIVE - ZGA060

**BLOWER TABLE INCLUDES RESISTANCE FOR BASE UNIT ONLY WITH DRY INDOOR COIL AND AIR FILTERS IN PLACE.**

FOR ALL UNITS ADD:

1 - Any factory installed options air resistance (heat section, economizer, wet coil, etc.).

2 - Any field installed accessories air resistance (duct resistance, diffuser, etc.).

See page 17 for blower motors and drives and wet coil and options/accessory air resistance data.

### DOWNFLOW

Air Volume cfm	External Static - in. w.g.															
	0.10		0.20		0.30		0.40		0.50		0.60		0.70		0.80	
	RPM	BHP	RPM	BHP	RPM	BHP	RPM	BHP	RPM	BHP	RPM	BHP	RPM	BHP	RPM	BHP
	Field Furnished				Kit Z03											
1600	817	0.39	877	0.42	935	0.45	989	0.48	1040	0.52	1087	0.56	1131	0.60	1173	0.65
1700	859	0.44	917	0.47	972	0.50	1023	0.54	1071	0.58	1117	0.62	1159	0.67	1199	0.71
1800	902	0.49	957	0.53	1008	0.56	1057	0.60	1103	0.64	1147	0.69	1188	0.74	1227	0.79
1900	944	0.56	996	0.59	1045	0.63	1092	0.68	1136	0.72	1178	0.77	1218	0.82	1257	0.87
2000	986	0.63	1035	0.67	1083	0.71	1127	0.76	1170	0.81	1210	0.86	1249	0.91	1287	0.97
2100	1027	0.71	1075	0.75	1120	0.80	1163	0.85	1204	0.90	1243	0.96	1281	1.02	1318	1.07
2200	1069	0.80	1115	0.84	1158	0.90	1200	0.95	1239	1.01	1277	1.07	1314	1.13	1350	1.19
2300	1111	0.90	1155	0.95	1197	1.01	1237	1.07	1275	1.13	1312	1.19	1348	1.25	1383	1.31
2400	1154	1.01	1196	1.07	1236	1.13	1274	1.19	1311	1.25	1347	1.32	1382	1.38	1417	1.45

Air Volume cfm	External Static - in. w.g.															
	0.90		1.00		1.10		1.20		1.30		1.40		1.50		1.60	
	RPM	BHP	RPM	BHP	RPM	BHP	RPM	BHP	RPM	BHP	RPM	BHP	RPM	BHP	RPM	BHP
	Kit Z03								Kit Z06							
1600	1213	0.69	1252	0.73	1292	0.77	1330	0.81	1367	0.85	1403	0.89	1438	0.94	1472	0.98
1700	1239	0.76	1278	0.80	1316	0.84	1354	0.89	1390	0.93	1425	0.98	1459	1.02	1492	1.07
1800	1266	0.83	1304	0.88	1342	0.93	1378	0.98	1414	1.02	1448	1.07	1481	1.12	1514	1.16
1900	1294	0.92	1332	0.97	1369	1.02	1404	1.07	1439	1.12	1472	1.17	1504	1.21	1536	1.26
2000	1324	1.02	1360	1.07	1396	1.13	1431	1.18	1465	1.23	1497	1.27	1529	1.32	1560	1.37
2100	1354	1.13	1390	1.18	1425	1.24	1459	1.29	1491	1.34	1523	1.39	1554	1.43	1585	1.48
2200	1385	1.25	1420	1.30	1454	1.36	1487	1.41	1519	1.46	1550	1.51	1581	1.55	1611	1.60
2300	1418	1.37	1452	1.43	1485	1.48	1517	1.53	1548	1.58	1578	1.63	1608	1.68	1639	1.72
2400	1451	1.51	1484	1.56	1516	1.62	1547	1.67	1578	1.72	1607	1.76	1637	1.81	1667	1.85

### HORIZONTAL

Air Volume cfm	External Static - in. w.g.															
	0.10		0.20		0.30		0.40		0.50		0.60		0.70		0.80	
	RPM	BHP	RPM	BHP	RPM	BHP	RPM	BHP	RPM	BHP	RPM	BHP	RPM	BHP	RPM	BHP
	Field Furnished				Kit Z03											
1600	817	0.39	878	0.42	934	0.46	985	0.49	1034	0.53	1080	0.56	1123	0.60	1164	0.64
1700	861	0.45	918	0.48	970	0.51	1018	0.55	1065	0.58	1108	0.62	1150	0.66	1190	0.70
1800	904	0.51	957	0.54	1006	0.57	1052	0.61	1096	0.65	1138	0.69	1178	0.73	1217	0.78
1900	946	0.57	996	0.61	1042	0.64	1086	0.68	1128	0.72	1168	0.76	1207	0.81	1245	0.86
2000	988	0.64	1035	0.68	1079	0.72	1120	0.76	1161	0.81	1199	0.85	1237	0.90	1275	0.96
2100	1028	0.72	1073	0.76	1115	0.81	1155	0.85	1194	0.90	1231	0.95	1268	1.01	1305	1.07
2200	1068	0.81	1111	0.86	1151	0.90	1190	0.95	1227	1.00	1263	1.06	1299	1.12	1336	1.18
2300	1108	0.91	1149	0.96	1188	1.01	1225	1.06	1261	1.12	1296	1.18	1332	1.24	1367	1.31
2400	1148	1.02	1187	1.07	1224	1.13	1260	1.18	1295	1.25	1330	1.31	1365	1.38	1400	1.45

Air Volume cfm	External Static - in. w.g.															
	0.90		1.00		1.10		1.20		1.30		1.40		1.50		1.60	
	RPM	BHP	RPM	BHP	RPM	BHP	RPM	BHP	RPM	BHP	RPM	BHP	RPM	BHP	RPM	BHP
	Kit Z03								Kit Z06							
1600	1204	0.68	1245	0.72	1285	0.76	1325	0.81	1363	0.86	1401	0.91	1437	0.96	1473	1.01
1700	1229	0.75	1269	0.79	1309	0.84	1348	0.89	1386	0.94	1423	1.00	1458	1.05	1493	1.10
1800	1256	0.83	1295	0.88	1334	0.93	1372	0.98	1409	1.04	1445	1.09	1481	1.15	1515	1.20
1900	1283	0.92	1322	0.97	1360	1.03	1397	1.08	1434	1.14	1469	1.20	1504	1.25	1537	1.31
2000	1312	1.02	1350	1.07	1387	1.13	1424	1.19	1459	1.25	1494	1.31	1528	1.37	1561	1.42
2100	1342	1.13	1378	1.19	1415	1.25	1451	1.31	1486	1.37	1519	1.43	1553	1.49	1586	1.54
2200	1372	1.25	1408	1.31	1444	1.37	1479	1.44	1513	1.50	1546	1.56	1579	1.61	1611	1.67
2300	1403	1.38	1438	1.44	1473	1.51	1507	1.57	1541	1.63	1573	1.69	1606	1.75	1638	1.80
2400	1434	1.52	1469	1.58	1503	1.65	1537	1.71	1569	1.77	1601	1.83	1633	1.88	1665	1.94

## BLOWER DATA - BELT DRIVE - ZCA036

**BLOWER TABLE INCLUDES RESISTANCE FOR BASE UNIT ONLY WITH DRY INDOOR COIL AND AIR FILTERS IN PLACE.**

FOR ALL UNITS ADD:

1 - Any factory installed options air resistance (heat section, economizer, wet coil, etc.).

2 - Any field installed accessories air resistance (duct resistance, diffuser, etc.).

See page 17 for blower motors and drives and wet coil and options/accessory air resistance data.

### DOWNFLOW

Air Volume cfm	External Static - in. w.g.															
	0.10		0.20		0.30		0.40		0.50		0.60		0.70		0.80	
	RPM	BHP	RPM	BHP	RPM	BHP	RPM	BHP	RPM	BHP	RPM	BHP	RPM	BHP	RPM	BHP
	Field Furnished				Kit Z01											
900	555	0.16	621	0.17	691	0.19	763	0.20	832	0.22	897	0.24	956	0.26	1010	0.29
1000	577	0.18	644	0.19	715	0.21	786	0.23	855	0.24	919	0.27	976	0.29	1028	0.32
1100	601	0.20	670	0.22	741	0.23	812	0.25	879	0.28	941	0.30	996	0.33	1047	0.37
1200	629	0.22	698	0.24	770	0.26	840	0.28	905	0.31	965	0.34	1018	0.38	1066	0.41
1300	659	0.25	729	0.27	800	0.30	869	0.32	932	0.35	989	0.39	1040	0.43	1087	0.47
1400	692	0.28	763	0.31	833	0.34	899	0.37	960	0.40	1014	0.44	1063	0.48	1108	0.52
1500	728	0.32	798	0.35	866	0.38	930	0.41	987	0.45	1039	0.50	1086	0.54	1130	0.58

Air Volume cfm	External Static - in. w.g.															
	0.90		1.00		1.10		1.20		1.30		1.40		1.50		1.60	
	RPM	BHP	RPM	BHP	RPM	BHP	RPM	BHP	RPM	BHP	RPM	BHP	RPM	BHP	RPM	BHP
	Kit Z04															
900	1060	0.31	1108	0.34	1154	0.37	1197	0.40	1239	0.44	1279	0.47	1319	0.51	1359	0.55
1000	1077	0.35	1123	0.38	1168	0.42	1211	0.45	1252	0.49	1291	0.52	1330	0.56	1370	0.60
1100	1094	0.40	1139	0.43	1183	0.46	1225	0.50	1266	0.54	1305	0.58	1343	0.62	1382	0.66
1200	1112	0.45	1156	0.48	1199	0.52	1241	0.55	1281	0.59	1319	0.64	1357	0.68	1394	0.72
1300	1131	0.50	1174	0.54	1216	0.57	1257	0.61	1296	0.66	1334	0.70	1371	0.74	1408	0.78
1400	1151	0.56	1193	0.60	1234	0.64	1274	0.68	1313	0.72	1351	0.77	1387	0.81	1423	0.86
1500	1172	0.62	1213	0.66	1253	0.71	1293	0.75	1331	0.79	1368	0.84	1404	0.89	1440	0.93

### HORIZONTAL

Air Volume cfm	External Static - in. w.g.																	
	0.10		0.20		0.30		0.40		0.50		0.60		0.70		0.80			
	RPM	BHP	RPM	BHP	RPM	BHP	RPM	BHP	RPM	BHP	RPM	BHP	RPM	BHP	RPM	BHP		
	Field Furnished				Kit Z01												Kit Z04	
900	572	0.14	641	0.16	712	0.19	785	0.22	860	0.24	931	0.27	991	0.29	1039	0.32		
1000	602	0.16	671	0.19	742	0.22	815	0.24	887	0.27	954	0.30	1010	0.33	1055	0.36		
1100	636	0.19	706	0.22	776	0.25	847	0.28	916	0.31	977	0.34	1028	0.37	1070	0.41		
1200	674	0.23	744	0.26	813	0.29	881	0.32	944	0.35	999	0.38	1045	0.42	1087	0.45		
1300	716	0.26	784	0.29	851	0.33	914	0.36	971	0.40	1020	0.43	1064	0.47	1106	0.50		
1400	759	0.30	824	0.34	888	0.37	946	0.41	998	0.45	1043	0.49	1086	0.52	1129	0.55		
1500	803	0.35	865	0.39	925	0.43	979	0.47	1027	0.52	1070	0.55	1113	0.58	1156	0.61		

Air Volume cfm	External Static - in. w.g.															
	0.90		1.00		1.10		1.20		1.30		1.40		1.50		1.60	
	RPM	BHP	RPM	BHP	RPM	BHP	RPM	BHP	RPM	BHP	RPM	BHP	RPM	BHP	RPM	BHP
	Kit Z04															
900	1085	0.35	1135	0.38	1183	0.40	1227	0.42	1268	0.45	1305	0.49	1342	0.53	1379	0.57
1000	1099	0.39	1148	0.42	1195	0.44	1239	0.47	1279	0.50	1316	0.54	1352	0.58	1389	0.62
1100	1114	0.44	1163	0.46	1210	0.49	1253	0.52	1292	0.55	1329	0.59	1364	0.64	1401	0.68
1200	1131	0.48	1180	0.51	1226	0.54	1269	0.57	1308	0.61	1343	0.66	1378	0.70	1414	0.75
1300	1151	0.53	1199	0.56	1245	0.59	1287	0.63	1324	0.68	1359	0.72	1394	0.77	1429	0.82
1400	1175	0.58	1222	0.62	1266	0.66	1306	0.70	1342	0.75	1376	0.80	1410	0.85	1446	0.89
1500	1201	0.65	1246	0.68	1289	0.73	1327	0.78	1362	0.83	1395	0.88	1429	0.93	1464	0.98

## BLOWER DATA - BELT DRIVE - ZCA048

**BLOWER TABLE INCLUDES RESISTANCE FOR BASE UNIT ONLY WITH DRY INDOOR COIL AND AIR FILTERS IN PLACE.**

FOR ALL UNITS ADD:

1 - Any factory installed options air resistance (heat section, economizer, wet coil, etc.).

2 - Any field installed accessories air resistance (duct resistance, diffuser, etc.).

See page 17 for blower motors and drives and wet coil and options/accessory air resistance data.

### DOWNFLOW

Air Volume cfm	External Static - in. w.g.															
	0.10		0.20		0.30		0.40		0.50		0.60		0.70		0.80	
	RPM	BHP	RPM	BHP	RPM	BHP	RPM	BHP	RPM	BHP	RPM	BHP	RPM	BHP	RPM	BHP
	Field Furnished						Kit Z02									
1200	629	0.22	698	0.24	770	0.26	840	0.28	905	0.31	965	0.34	1018	0.38	1066	0.41
1300	659	0.25	729	0.27	800	0.30	869	0.32	932	0.35	989	0.39	1040	0.43	1087	0.47
1400	692	0.28	763	0.31	833	0.34	899	0.37	960	0.40	1014	0.44	1063	0.48	1108	0.52
1500	728	0.32	798	0.35	866	0.38	930	0.41	987	0.45	1039	0.50	1086	0.54	1130	0.58
1600	766	0.37	835	0.40	900	0.43	960	0.47	1015	0.51	1065	0.55	1110	0.60	1152	0.65
1700	806	0.42	871	0.45	934	0.48	991	0.52	1043	0.56	1091	0.61	1134	0.66	1176	0.71
1800	845	0.47	908	0.50	967	0.54	1021	0.58	1071	0.63	1117	0.68	1159	0.73	1200	0.78
1900	884	0.53	944	0.56	1000	0.60	1051	0.64	1099	0.69	1143	0.75	1185	0.80	1225	0.86
2000	923	0.59	979	0.63	1032	0.67	1082	0.72	1128	0.77	1171	0.83	1211	0.89	1251	0.95

Air Volume cfm	External Static - in. w.g.															
	0.90		1.00		1.10		1.20		1.30		1.40		1.50		1.60	
	RPM	BHP	RPM	BHP	RPM	BHP	RPM	BHP	RPM	BHP	RPM	BHP	RPM	BHP	RPM	BHP
	Kit Z02						Kit Z05									
1200	1112	0.45	1156	0.48	1199	0.52	1241	0.55	1281	0.59	1319	0.64	1357	0.68	1394	0.72
1300	1131	0.50	1174	0.54	1216	0.57	1257	0.61	1296	0.66	1334	0.70	1371	0.74	1408	0.78
1400	1151	0.56	1193	0.60	1234	0.64	1274	0.68	1313	0.72	1351	0.77	1387	0.81	1423	0.86
1500	1172	0.62	1213	0.66	1253	0.71	1293	0.75	1331	0.79	1368	0.84	1404	0.89	1440	0.93
1600	1193	0.69	1234	0.73	1273	0.78	1313	0.82	1350	0.87	1387	0.92	1422	0.97	1457	1.01
1700	1216	0.76	1255	0.81	1295	0.86	1333	0.90	1370	0.95	1406	1.00	1441	1.05	1475	1.10
1800	1239	0.84	1279	0.89	1317	0.94	1355	0.99	1391	1.04	1426	1.09	1461	1.14	1494	1.19
1900	1264	0.92	1303	0.98	1341	1.03	1378	1.08	1413	1.14	1448	1.19	1481	1.24	1514	1.29
2000	1290	1.01	1328	1.07	1366	1.13	1402	1.19	1436	1.24	1470	1.29	1503	1.35	1535	1.40

### HORIZONTAL

Air Volume cfm	External Static - in. w.g.															
	0.10		0.20		0.30		0.40		0.50		0.60		0.70		0.80	
	RPM	BHP	RPM	BHP	RPM	BHP	RPM	BHP	RPM	BHP	RPM	BHP	RPM	BHP	RPM	BHP
	Field Furnished						Kit Z02									
1200	674	0.23	744	0.26	813	0.29	881	0.32	944	0.35	999	0.38	1045	0.42	1087	0.45
1300	716	0.26	784	0.29	851	0.33	914	0.36	971	0.40	1020	0.43	1064	0.47	1106	0.50
1400	759	0.30	824	0.34	888	0.37	946	0.41	998	0.45	1043	0.49	1086	0.52	1129	0.55
1500	803	0.35	865	0.39	925	0.43	979	0.47	1027	0.52	1070	0.55	1113	0.58	1156	0.61
1600	847	0.40	905	0.45	961	0.50	1013	0.54	1058	0.58	1100	0.62	1142	0.65	1185	0.68
1700	890	0.47	944	0.52	997	0.57	1047	0.62	1091	0.66	1132	0.69	1173	0.72	1216	0.76
1800	930	0.54	982	0.60	1033	0.65	1081	0.70	1124	0.74	1165	0.77	1206	0.80	1248	0.84
1900	970	0.62	1020	0.68	1069	0.73	1116	0.78	1158	0.81	1199	0.85	1239	0.89	1280	0.93
2000	1009	0.71	1058	0.76	1106	0.81	1151	0.86	1193	0.9	1233	0.94	1273	0.98	1312	1.04

Air Volume cfm	External Static - in. w.g.															
	0.90		1.00		1.10		1.20		1.30		1.40		1.50		1.60	
	RPM	BHP	RPM	BHP	RPM	BHP	RPM	BHP	RPM	BHP	RPM	BHP	RPM	BHP	RPM	BHP
	Kit Z02						Kit Z05									
1200	1131	0.48	1180	0.51	1226	0.54	1269	0.57	1308	0.61	1343	0.66	1378	0.70	1414	0.75
1300	1151	0.53	1199	0.56	1245	0.59	1287	0.63	1324	0.68	1359	0.72	1394	0.77	1429	0.82
1400	1175	0.58	1222	0.62	1266	0.66	1306	0.70	1342	0.75	1376	0.80	1410	0.85	1446	0.89
1500	1201	0.65	1246	0.68	1289	0.73	1327	0.78	1362	0.83	1395	0.88	1429	0.93	1464	0.98
1600	1229	0.72	1273	0.76	1313	0.81	1350	0.86	1384	0.92	1416	0.97	1450	1.02	1485	1.07
1700	1258	0.80	1300	0.85	1338	0.90	1374	0.96	1407	1.02	1440	1.07	1473	1.12	1508	1.17
1800	1289	0.89	1328	0.94	1365	1.00	1399	1.06	1432	1.13	1465	1.18	1498	1.23	1532	1.28
1900	1319	0.99	1357	1.05	1392	1.11	1426	1.18	1459	1.24	1491	1.30	1524	1.35	1558	1.39
2000	1350	1.10	1387	1.16	1421	1.23	1454	1.30	1486	1.36	1518	1.42	1551	1.47	1584	1.51

## BLOWER DATA - BELT DRIVE - ZCA060

**BLOWER TABLE INCLUDES RESISTANCE FOR BASE UNIT ONLY WITH DRY INDOOR COIL AND AIR FILTERS IN PLACE.**

FOR ALL UNITS ADD:

1 - Any factory installed options air resistance (heat section, economizer, wet coil, etc.).

2 - Any field installed accessories air resistance (duct resistance, diffuser, etc.).

See page 17 for blower motors and drives and wet coil and options/accessory air resistance data.

### DOWNFLOW

Air Volume cfm	External Static - in. w.g.															
	0.10		0.20		0.30		0.40		0.50		0.60		0.70		0.80	
	RPM	BHP	RPM	BHP	RPM	BHP	RPM	BHP	RPM	BHP	RPM	BHP	RPM	BHP	RPM	BHP
	Field Furnished				Kit Z03											
1600	787	0.38	854	0.41	918	0.44	976	0.48	1030	0.52	1078	0.56	1123	0.61	1164	0.66
1700	827	0.43	892	0.46	952	0.49	1007	0.53	1058	0.58	1105	0.63	1148	0.68	1189	0.73
1800	868	0.48	929	0.52	986	0.55	1038	0.59	1087	0.64	1132	0.69	1174	0.75	1214	0.80
1900	907	0.54	966	0.58	1019	0.62	1069	0.66	1116	0.71	1160	0.77	1200	0.82	1240	0.88
2000	946	0.60	1001	0.65	1053	0.69	1101	0.74	1146	0.79	1188	0.85	1228	0.91	1267	0.98
2100	984	0.68	1037	0.72	1086	0.77	1132	0.83	1176	0.89	1217	0.95	1256	1.01	1295	1.08
2200	1021	0.75	1072	0.81	1120	0.86	1165	0.92	1207	0.99	1247	1.05	1286	1.12	1324	1.19
2300	1059	0.84	1108	0.90	1154	0.96	1197	1.03	1239	1.10	1278	1.17	1316	1.24	1354	1.32
2400	1097	0.95	1144	1.01	1188	1.08	1231	1.15	1271	1.22	1310	1.30	1348	1.38	1385	1.45

Air Volume cfm	External Static - in. w.g.															
	0.90		1.00		1.10		1.20		1.30		1.40		1.50		1.60	
	RPM	BHP	RPM	BHP	RPM	BHP	RPM	BHP	RPM	BHP	RPM	BHP	RPM	BHP	RPM	BHP
	Kit Z03								Kit Z06							
1600	1205	0.70	1245	0.75	1284	0.79	1323	0.84	1361	0.88	1397	0.93	1432	0.98	1467	1.03
1700	1228	0.78	1268	0.82	1307	0.87	1345	0.92	1382	0.97	1417	1.02	1452	1.07	1486	1.11
1800	1253	0.85	1292	0.91	1331	0.96	1368	1.01	1404	1.06	1439	1.11	1473	1.16	1506	1.21
1900	1279	0.94	1317	1.00	1355	1.05	1392	1.10	1427	1.16	1461	1.21	1494	1.26	1527	1.31
2000	1305	1.04	1343	1.10	1380	1.15	1416	1.21	1450	1.26	1484	1.32	1516	1.37	1549	1.42
2100	1333	1.14	1370	1.21	1407	1.26	1442	1.32	1475	1.38	1508	1.43	1540	1.48	1572	1.53
2200	1361	1.26	1398	1.32	1434	1.38	1468	1.44	1501	1.50	1533	1.55	1564	1.61	1596	1.66
2300	1391	1.39	1427	1.45	1462	1.51	1495	1.57	1527	1.63	1559	1.68	1590	1.73	1622	1.78
2400	1421	1.52	1456	1.59	1490	1.65	1523	1.71	1555	1.76	1586	1.82	1617	1.87	1649	1.92

### HORIZONTAL

Air Volume cfm	External Static - in. w.g.															
	0.10		0.20		0.30		0.40		0.50		0.60		0.70		0.80	
	RPM	BHP	RPM	BHP	RPM	BHP	RPM	BHP	RPM	BHP	RPM	BHP	RPM	BHP	RPM	BHP
	Field Furn.		Kit Z03													
1600	864	0.42	921	0.46	976	0.51	1027	0.56	1072	0.60	1113	0.63	1155	0.66	1198	0.69
1700	907	0.48	961	0.53	1013	0.58	1061	0.63	1105	0.67	1146	0.70	1187	0.73	1230	0.77
1800	948	0.56	999	0.61	1049	0.66	1096	0.71	1139	0.75	1180	0.78	1221	0.82	1262	0.86
1900	987	0.64	1037	0.69	1086	0.74	1132	0.79	1174	0.83	1214	0.86	1255	0.90	1295	0.95
2000	1028	0.73	1076	0.78	1123	0.83	1168	0.87	1210	0.91	1250	0.96	1289	1.00	1328	1.06
2100	1071	0.81	1117	0.86	1163	0.91	1206	0.96	1247	1.01	1286	1.06	1324	1.12	1362	1.18
2200	1116	0.91	1160	0.96	1204	1.01	1245	1.07	1285	1.12	1323	1.18	1360	1.25	1396	1.31
2300	1161	1.02	1204	1.07	1245	1.13	1285	1.19	1323	1.25	1360	1.32	1396	1.38	1432	1.45
2400	1207	1.14	1248	1.20	1288	1.26	1326	1.32	1362	1.39	1398	1.46	1433	1.53	1468	1.60

Air Volume cfm	External Static - in. w.g.															
	0.90		1.00		1.10		1.20		1.30		1.40		1.50		1.60	
	RPM	BHP	RPM	BHP	RPM	BHP	RPM	BHP	RPM	BHP	RPM	BHP	RPM	BHP	RPM	BHP
	Kit Z03								Kit Z06							
1600	1242	0.73	1284	0.77	1324	0.82	1360	0.88	1394	0.93	1426	0.99	1460	1.04	1495	1.08
1700	1272	0.81	1312	0.86	1350	0.92	1385	0.98	1418	1.04	1451	1.09	1485	1.14	1519	1.19
1800	1302	0.90	1341	0.96	1377	1.02	1411	1.08	1444	1.15	1477	1.20	1510	1.25	1544	1.30
1900	1334	1.01	1371	1.07	1406	1.13	1439	1.20	1471	1.26	1504	1.32	1537	1.37	1571	1.41
2000	1365	1.12	1401	1.19	1435	1.25	1468	1.32	1500	1.38	1532	1.44	1565	1.49	1598	1.53
2100	1398	1.25	1433	1.31	1466	1.38	1497	1.45	1529	1.51	1561	1.56	1594	1.61	1626	1.65
2200	1431	1.38	1465	1.45	1497	1.52	1528	1.58	1560	1.64	1591	1.69	1623	1.73	1656	1.77
2300	1466	1.52	1498	1.59	1529	1.66	1560	1.72	1591	1.77	1623	1.82	1654	1.86	1686	1.90
2400	1500	1.67	1532	1.74	1563	1.80	1593	1.86	1624	1.91	1655	1.96	1686	2.00	1718	2.04



## BLOWER DATA

### DRIVE KIT SPECIFICATIONS

Model No.	Blower Motor Choice (HP)				Drive Kit No.	RPM Range
	Nominal	Maximum	Nominal	Maximum		
036	1	1.15	1.5	1.7	Z01	678 - 1035
					Z04	964 - 1471
048	1	1.15	1.5	1.7	Z02	803 - 1226
					Z05	1098 - 1490
060	1	1.15	1.5	1.7	Z03	906 - 1383
					Z06	1262 - 1634

NOTE - Using total air volume and system static pressure requirements determine from blower performance tables rpm and motor hp required. Maximum usable hp of motors furnished are shown. In Canada, nominal motor hp is also maximum usable motor hp. If motors of comparable hp are used, be sure to keep within the service factor limitations outlined on the motor nameplate.

### POWER EXHAUST FAN PERFORMANCE

Return Air System Static Pressure - in. w.g.	Air Volume Exhausted cfm
0.00	1865
0.05	1785
0.10	1710
0.15	1630
0.20	1545
0.25	1450
0.30	1350
0.35	1240

### OPTIONS / ACCESSORIES AIR RESISTANCE FOR 036-060 MODELS - in. w.g.

Air Volume cfm	Wet Indoor Coil		Gas Heat		Electric Heat	Economizer	
	036-048	060	Medium Input	High Input		Downflow	Horizontal
900	0.01	---	0.02	0.02	0.02	0.04	0.05
1000	0.01	---	0.02	0.02	0.04	0.04	0.05
1100	0.02	---	0.02	0.02	0.05	0.04	0.06
1200	0.02	---	0.02	0.03	0.06	0.05	0.06
1300	0.02	---	0.02	0.03	0.08	0.05	0.07
1400	0.03	---	0.03	0.04	0.09	0.06	0.07
1500	0.03	---	0.03	0.04	0.10	0.07	0.08
1600	0.03	0.04	0.03	0.04	0.12	0.08	0.09
1700	0.04	0.05	0.03	0.05	0.13	0.08	0.10
1800	0.04	0.05	0.03	0.05	0.15	0.09	0.11
1900	0.04	0.06	0.04	0.06	0.16	0.10	0.12
2000	0.05	0.06	0.04	0.06	0.17	0.12	0.13
2100	---	0.07	0.04	0.06	0.19	0.13	0.14
2200	---	0.08	0.04	0.07	0.20	0.14	0.15
2300	---	0.08	0.04	0.07	0.21	0.15	0.17
2400	---	0.09	0.05	0.80	0.23	0.17	0.18

**TABLE 4  
DRIVE COMPONENT MANUFACTURER'S NUMBERS**

Drive No.	DRIVE COMPONENT PART NUMBERS					
	Motor Pulley		Blower Pulley		Belts	
	Browning	OEM	Browning	OEM	Browning	OEM
Z01	1VP34 X 7/8	31K6901	AK54 X 5/8	100244-30	A40	100245-17
Z02	1VP34 X 7/8	31K6901	AK46 X 5/8	100244-31	A39	100245-16
Z03	1VP34 X 7/8	31K6901	AK41 X 5/8	100244-28	A39	100245-16
Z04	1VP34 X 7/8	31K6901	AK39 X 5/8	100244-32	A38	100245-15
Z05	1VP44 X 7/8	P-8-1488	AK49 X 5/8	100244-26	A41	100245-18
Z06	1VP50 X 7/8	53J1501	AK51 X 5/8	100244-29	A42	100245-19

**TABLE 5  
MINIMUM AIRFLOW  
ZC UNITS WITH ELECTRIC HEAT**

Kw	CFM
	Downflow and Horizontal
5	960
7.5	960
10	960
15	960
22.5	1280

Units with electric heat (5-22.5kW) can operate up to 1.6" w.g. maximum static pressure.

**Cooling Start-Up**

**A-Operation**

- 1- Initiate first and second stage cooling demands according to instructions provided with thermostat.
- 2- *No Economizer Installed in Unit* -  
A first-stage cooling demand (Y1) will energize compressor 1 and the condenser fan. An increased cooling demand (Y2) will not change operation.  
*Units Equipped With Economizer* -  
When outdoor air is acceptable, a first-stage cooling demand (Y1) will energize the economizer. An increased cooling demand (Y2) will energize compressor 1 and the condenser fan. When outdoor air is not acceptable unit will operate as though no economizer is installed.
- 3- Units contain one refrigerant circuit or stage.
- 4- Unit is charged with R-410A refrigerant. See unit rating plate for correct amount of charge.
- 5- Refer to Refrigerant Charge and Check section for proper method to check refrigerant charge.

**B-Three Phase Scroll Compressor Voltage Phasing**

Three phase scroll compressors must be phased sequentially to ensure correct compressor and blower rotation and operation. Compressor and blower are wired in phase at the factory. Power wires are color-coded as follows: line 1-red, line 2-yellow, line 3-blue.

- 1- Observe suction and discharge pressures and blower rotation on unit start-up.
- 2- Suction pressure must drop, discharge pressure must rise and blower rotation must match rotation marking.
- 3- Disconnect all remote electrical power supplies.
- 4- Reverse any two field-installed wires connected to the line side of K1 contactor. Do not reverse wires at blower contactor.
- 5- Make sure the connections are tight.

Discharge and suction pressures should operate at their normal start-up ranges.

**C-Refrigerant Charge and Check**

**WARNING-Do not exceed nameplate charge under any condition.**

This unit is factory charged and should require no further adjustment. If the system requires additional refrigerant, reclaim the charge, evacuate the system, and add required nameplate charge.

*NOTE - System charging is not recommended below 60°F (15°C). In temperatures below 60°F (15°C), the charge **must** be weighed into the system.*

If weighing facilities are not available, or to check the charge, use the following procedure:

**IMPORTANT - Charge unit in standard cooling mode high stage only.**

- 1- Make sure outdoor coil is clean. Attach gauge manifolds and operate unit at full CFM in cooling mode

with economizer disabled until system stabilizes (approximately five minutes). Make sure all outdoor air dampers are closed.

- 2- Compare the normal operating pressures (see tables 6 - 8) to the pressures obtained from the gauges. Check unit components if there are significant differences.
- 3- Measure the outdoor ambient temperature and the suction pressure. Refer to the appropriate circuit charging curve to determine a target liquid temperature.

*Note - Pressures are listed for sea level applications.*

- 4- Use the same thermometer to accurately measure the liquid temperature (in the outdoor section).
  - If measured liquid temperature is higher than the target liquid temperature, add refrigerant to the system.

- If measured liquid temperature is lower than the target liquid temperature, recover some refrigerant from the system.

- 5- Add or remove charge in increments. Allow the system to stabilize each time refrigerant is added or removed.
- 6- Continue the process until measured liquid temperature agrees with the target liquid temperature. Do not go below the target liquid temperature when adjusting charge. Note that suction pressure can change as charge is adjusted.
- 7- Example ZG/ZC 036: At 95°F outdoor ambient and a measured suction pressure of 130psig, the target liquid temperature is 102°F. For a measured liquid temperature of 106°F, add charge in increments until measured liquid temperature agrees with the target liquid temperature.

**TABLE 6  
ZG/ZC 036 NORMAL OPERATING PRESSURES - ALL-ALUMINUM COIL**

Outdoor Coil Entering Air Temperature											
65 °F		75 °F		85 °F		95 °F		105 °F		115 °F	
Suct (psig)	Disc (psig)	Suct (psig)	Disc (psig)	Suct (psig)	Disc (psig)	Suct (psig)	Disc (psig)	Suct (psig)	Disc (psig)	Suct (psig)	Disc (psig)
112	242	115	281	117	327	121	375	119	421	125	490
118	244	121	283	125	326	128	375	132	429	134	488
132	254	137	293	140	338	145	387	149	442	147	499
147	269	152	308	157	351	161	400	166	454	170	516

**TABLE 7  
ZG/ZC 048 NORMAL OPERATING PRESSURES - ALL-ALUMINUM COIL**

Outdoor Coil Entering Air Temperature											
65 °F		75 °F		85 °F		95 °F		105 °F		115 °F	
Suct (psig)	Disc (psig)	Suct (psig)	Disc (psig)	Suct (psig)	Disc (psig)	Suct (psig)	Disc (psig)	Suct (psig)	Disc (psig)	Suct (psig)	Disc (psig)
108	254	111	295	115	338	118	386	121	437	122	491
114	259	118	299	122	344	125	392	129	445	130	502
128	273	133	314	137	358	141	408	145	462	148	524
149	310	150	342	155	388	158	436	163	474	167	556

**TABLE 8  
ZG/ZC 060 NORMAL OPERATING PRESSURES - ALL-ALUMINUM COIL**

Outdoor Coil Entering Air Temperature											
65 °F		75 °F		85 °F		95 °F		105 °F		115 °F	
Suct (psig)	Disc (psig)	Suct (psig)	Disc (psig)	Suct (psig)	Disc (psig)	Suct (psig)	Disc (psig)	Suct (psig)	Disc (psig)	Suct (psig)	Disc (psig)
107	257	110	299	114	343	117	388	120	440	122	498
115	277	117	304	120	350	124	396	128	446	131	501
137	297	135	320	138	366	141	419	144	473	149	530
147	312	151	352	156	397	160	449	165	505	169	576

### ZG/ZC 036 CHARGING CURVE - ALL-ALUMINUM COIL

Outdoor Temperature (°F)

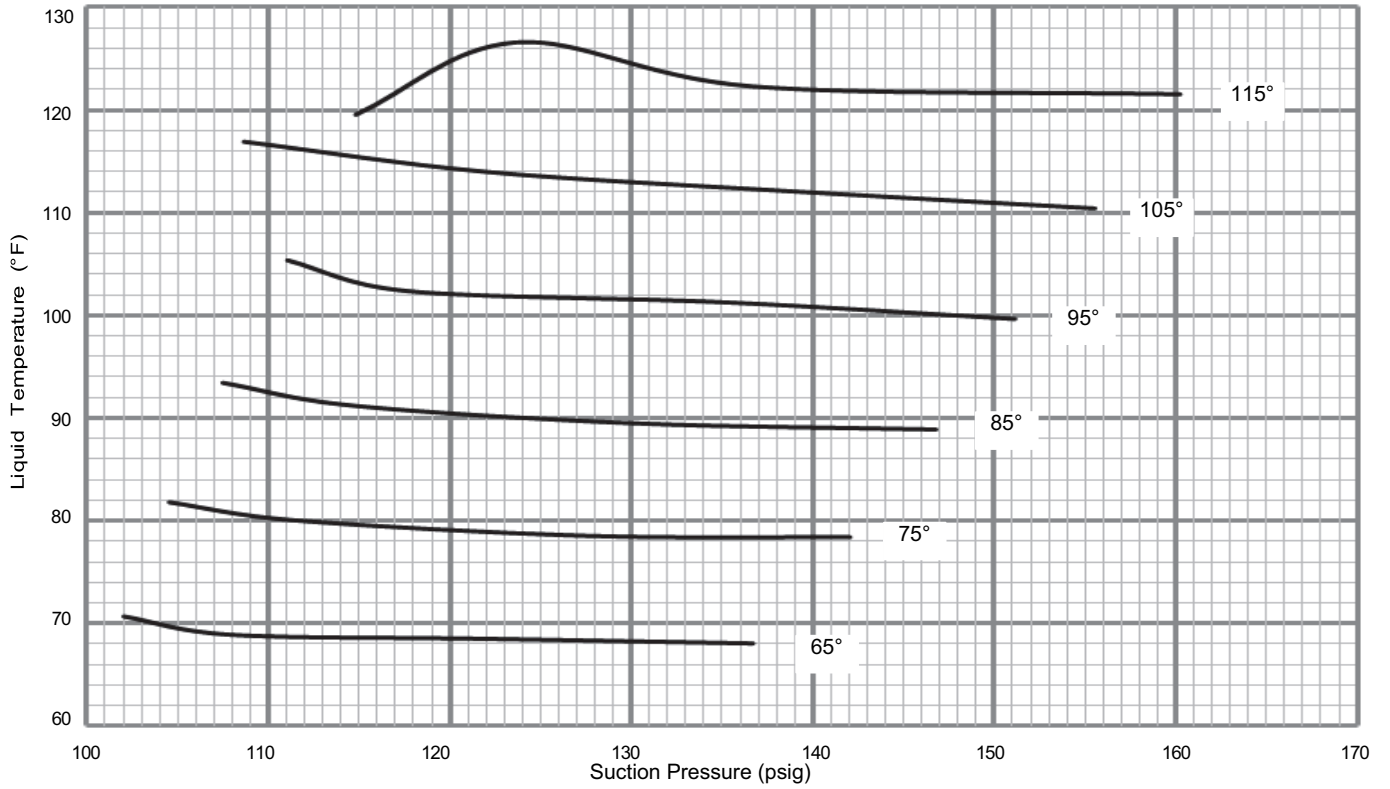

### ZG/ZC 048 CHARGING CURVE - ALL-ALUMINUM COIL

Outdoor Temperature (°F)

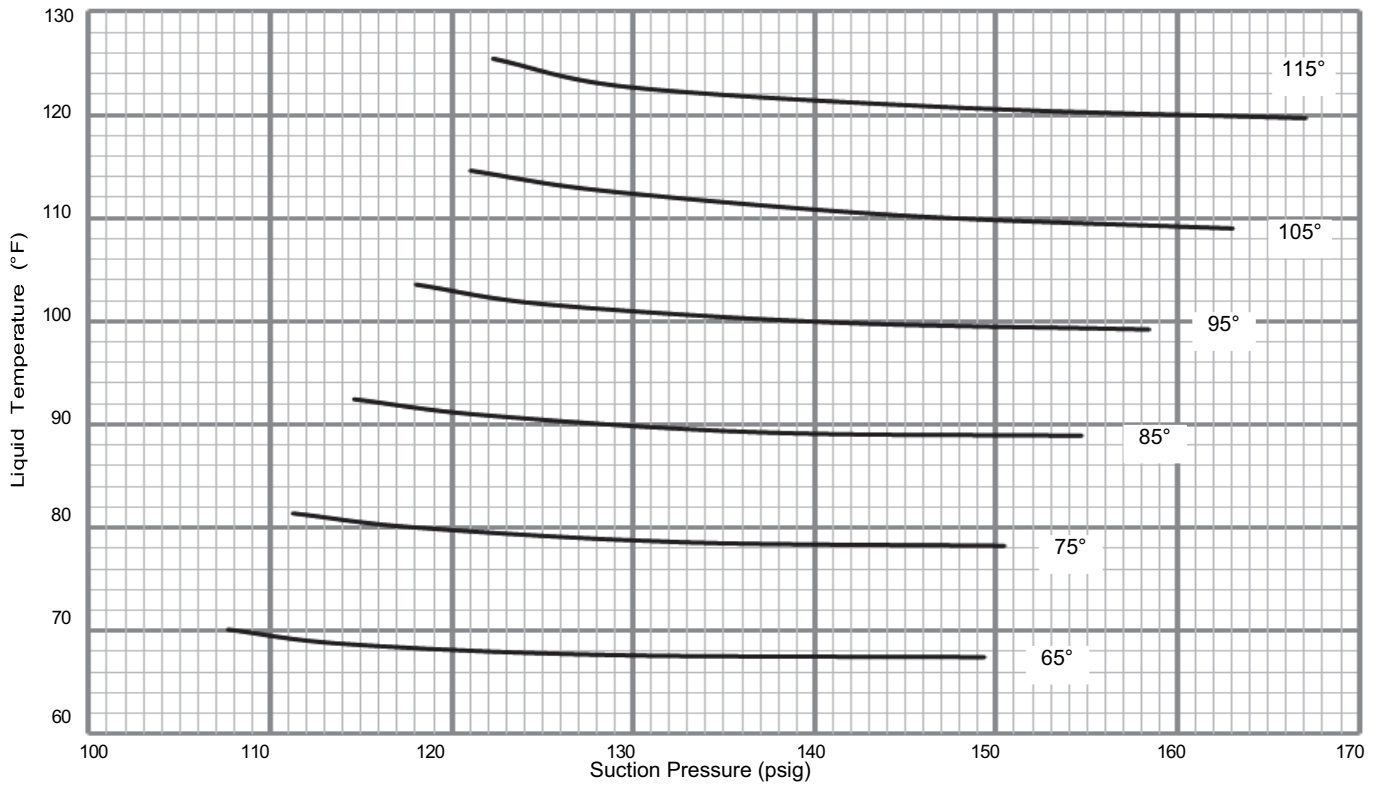

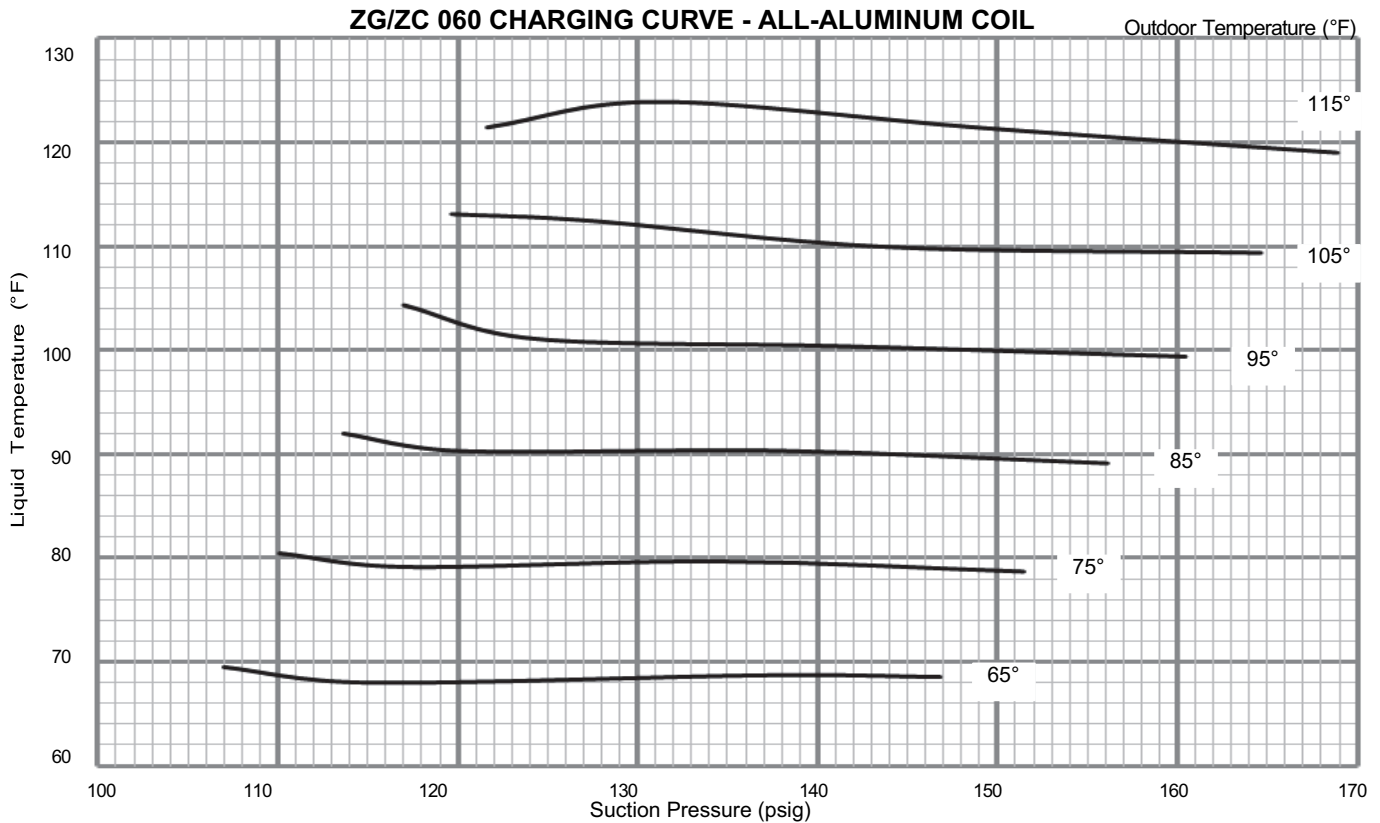

### D-Compressor Controls

See unit wiring diagram to determine which controls are used on each unit. Optional controls are identified on wiring diagrams by arrows at junction points.

#### 1- High Pressure Switch (S4)

The high pressure switch is a manual reset SPST N.C. switch which opens on a pressure rise.

S4 is located in the compressor discharge line and is wired in series with the compressor contactor coil.

When discharge pressure rises to  $640 \pm 10$  psig ( $4412 \pm 69$  kPa), indicating a problem with the system, the switch opens. The respective compressor is de-energized but the economizer can continue to operate.

#### 2- Compressor High Temperature Limit (S5)

The temperature limit switch S5 is located on the top of the compressor and is wired in series with the high pressure switch S4.

### Gas Heat Start-Up (Gas Units)

**FOR YOUR SAFETY READ BEFORE LIGHTING**

#### **⚠ WARNING**



**Electric shock hazard. Can cause injury or death. Do not use this unit if any part has been under water. Immediately call a qualified service technician to inspect the unit and to replace any part of the control system and any gas control which has been under water.**

#### **⚠ WARNING**



**Danger of explosion. Can cause injury or product or property damage. If overheating occurs or if gas supply fails to shut off, shut off the manual gas valve to the appliance before shutting off electrical supply.**

#### **⚠ WARNING**



**Electric shock hazard. Can cause injury or death. Before attempting to perform any service or maintenance, turn the electrical power to unit OFF at disconnect switch(es). Unit may have multiple power supplies.**

## ⚠️ WARNING

### SMOKE POTENTIAL

The heat exchanger in this unit could be a source of smoke on initial firing. Take precautions with respect to building occupants and property. Vent initial supply air outside when possible.

BEFORE LIGHTING smell all around the appliance area for gas. Be sure to smell next to the floor because some gas is heavier than air and will settle on the floor.

The gas valve may be equipped with either a gas control lever or gas control knob. Use only your hand to push the lever or turn the gas control knob. Never use tools. If the the lever will not move or the knob will not push in or turn by hand, do not try to repair it. Call a qualified service technician. Force or attempted repair may result in a fire or explosion.

## ⚠️ WARNING



**Danger of explosion. Can cause injury or death. Do not attempt to light manually. Unit has a direct spark ignition system.**

This unit is equipped with an automatic spark ignition system. There is no pilot. In case of a safety shutdown, move thermostat switch to **OFF** and return the thermostat switch to **HEAT** to reset ignition control.

### A-Placing Unit In Operation

## ⚠️ WARNING



**Danger of explosion and fire. Can cause injury or product or property damage. You must follow these instructions exactly.**

### Gas Valve Operation (figure 15 and 16)

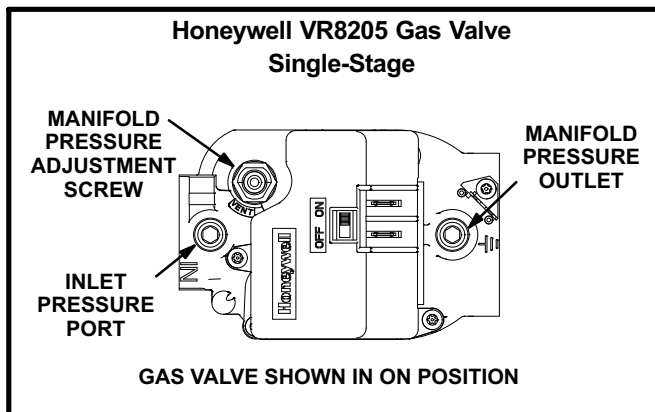

FIGURE 15

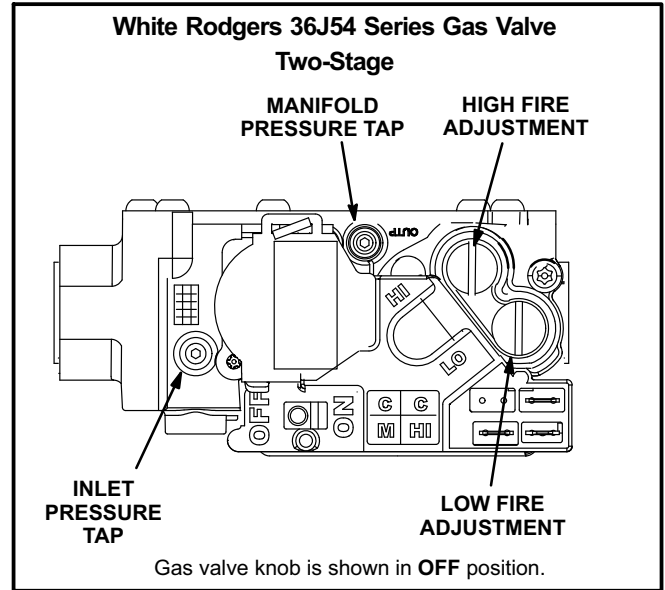





FIGURE 16

- 1- Set thermostat to lowest setting.
- 2- Turn off all electrical power to appliance.
- 3- This appliance is equipped with an ignition device which automatically lights the burner. Do **not** try to light the burner by hand.
- 4- Open or remove the heat section access panel.
- 5- *Honeywell VR8205 Gas Valve* - Switch gas valve lever to **OFF**. See figure 15.  
*White Rodgers 36J54 Gas Valve* - Turn knob on gas valve dockwise  to **OFF**. Do not force. See figure 16.
- 6- Wait five (5) minutes to clear out any gas. If you then smell gas, **STOP!** Immediately call your gas supplier from a neighbor's phone. Follow the gas supplier's instructions. If you do not smell gas, go to the next step.
- 7- *Honeywell VR8205 Gas Valve* - Switch gas valve lever to **ON**. See figure 15.  
*White Rodgers 36J54 Gas Valve* - Turn knob on gas valve counterclockwise  to **ON**. Do not force. See figure 16.
- 8- Close or replace the heat section access panel.
- 9- Turn on all electrical power to appliance.
- 10- Set thermostat to desired setting.  
*NOTE - When unit is initially started, steps 1 through 9 may need to be repeated to purge air from gas line.*
- 11- The ignition sequence will start.
- 12- If the furnace does not light the first time (gas line not fully purged), it will attempt up to two more ignitions before locking out.
- 13- If lockout occurs, repeat steps 1 through 10.
- 14- If the appliance will not operate, follow the instructions "Turning Off Gas to Appliance" and call your service technician or gas supplier.

## Turning Off Gas to Unit

- 1- If using an electromechanical thermostat, set to the lowest setting.
- 2- Before performing any service, turn off all electrical power to the appliance.
- 3- Open or remove the heat section access panel.
- 4- *Honeywell VR8205 Gas Valve* - Switch gas valve lever to **OFF**.  
*White Rodgers 36J54 Gas Valve* - Turn knob on gas valve clockwise  to **OFF**. Do not force.
- 5- Close or replace the heat section access panel.

<b>⚠ WARNING</b>	
	<b>Danger of explosion. Can cause injury or death. Do not attempt to light manually. Unit has a direct spark ignition system.</b>

## Heating Operation and Adjustments

### (Gas Units)

#### A-Heating Sequence of Operation

- 1- On a heating demand the combustion air inducer starts immediately.
- 2- Combustion air pressure switch proves inducer operation. After a 30-second pre-purge, power is allowed to ignition control. Switch is factory set and requires no adjustment.
- 3- Spark ignitor energizes and gas valve solenoid opens.
- 4- Spark ignites gas, ignition sensor proves the flame and combustion continues.
- 5- If flame is not detected after first ignition trial, ignition control will repeat steps 3 and 4 two more times before locking out the gas valve.
- 6- For troubleshooting purposes, an ignition attempt after lock out may be re-established manually. Move thermostat to "OFF" and return thermostat switch to "HEAT" position.

## B-Ignition Control Diagnostic LED's

**TABLE 9  
IGNITION CONTROL HEARTBEAT LED STATUS**

LED Flashes	Indicates
Slow	Normal operation. No call for heat.
Fast	Normal operation. Call for heat.
Steady Off	Internal control fault OR no power to control OR Gas Valve Relay Fault.
Steady On	Control internal failure.
2	Lockout. Failed to detect or sustain flame.
3	Prove switch open or closed or rollout switch open.
4	Limit switch is open and/or high limit has opened three times.
5	Flame sensed but gas valve solenoid not energized.

#### C-Limit Controls

Limit controls are factory-set and are not adjustable. The primary limit is located to the right of the combustion air inducer. See figure 22.

If the primary limit trips three times in the same heating cycle, heating operation will de-energize. Heating will automatically restart after one hour if a heating demand is present. To initiate heating during the one hour timed-off interval, reset the thermostat.

#### D-Heating Adjustment

Main burners are factory-set and do not require adjustment.

The following manifold pressures are listed on the gas valve.

- Natural Gas Units - Low Fire - 1.7" w.c.
- Natural Gas Units - High Fire - 3.5" w.c.
- LP Gas Units - Low Fire - 5.1" w.c.
- LP Gas Units - High Fire - 10.5" w.c.

## Electric Heat Start-Up (ZC Units)

Optional electric heat will stage on and cycle with thermostat demand. See electric heat wiring diagram on unit for sequence of operation.

## Service

The unit should be inspected once a year by a qualified service technician.

### ⚠ CAUTION

Label all wires prior to disconnection when servicing controls. Wiring errors can cause improper and dangerous operation. Verify proper operation after servicing.

### ⚠ WARNING

The State of California has determined that this product may contain or produce a chemical or chemicals, in very low doses, which may cause serious illness or death. It may also cause cancer, birth defects, or reproductive harm.

#### A-Filters

Units are equipped with temporary filters which must be replaced prior to building occupation. See table 10 for correct filter size. Refer to local codes or appropriate jurisdiction for approved filters.

**TABLE 10  
UNIT FILTERS**

Unit	Qty	Filter Size - inches (mm)
036, 048, 060	4	14 X 20 X 2 (352 X 508 X 51)

To change filters, open filter access panel on back side of unit. See figure 17. Lift filter stop to remove filters. See figure 18.

### ⚠ WARNING

Units are shipped from the factory with temporary filters. Replace filters before building is occupied. Damage to unit could result if filters are not replaced with approved filters. Refer to appropriate codes.

Approved filters should be checked monthly and replaced when necessary. Take note of air flow direction marking on filter frame when reinstalling filters. See figure 18.

*NOTE-Filters must be U.L.C. certified or equivalent for use in Canada.*

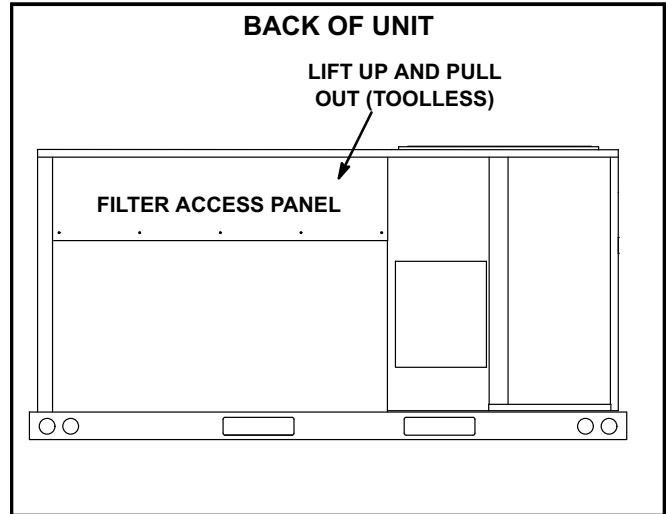

**FIGURE 17**

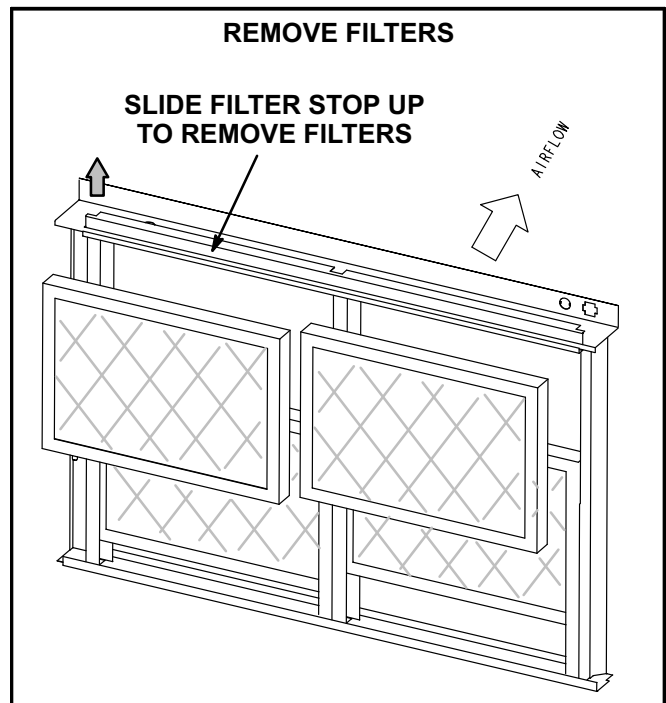

**FIGURE 18**

#### B-Lubrication

All motors are lubricated at the factory. No further lubrication is required.

#### C-Burners (Gas Units)

Periodically examine burner flames for proper appearance during the heating season. Before each heating season examine the burners for any deposits or blockage which may have occurred.

Clean burners as follows:

- 1- Turn off both electrical power and gas supply to unit.
- 2- Remove burner compartment access panel.
- 3- Remove top burner box panel.



- Remove two screws securing burners to burner support and lift the burners from the orifices. See figure 19. Clean as necessary.

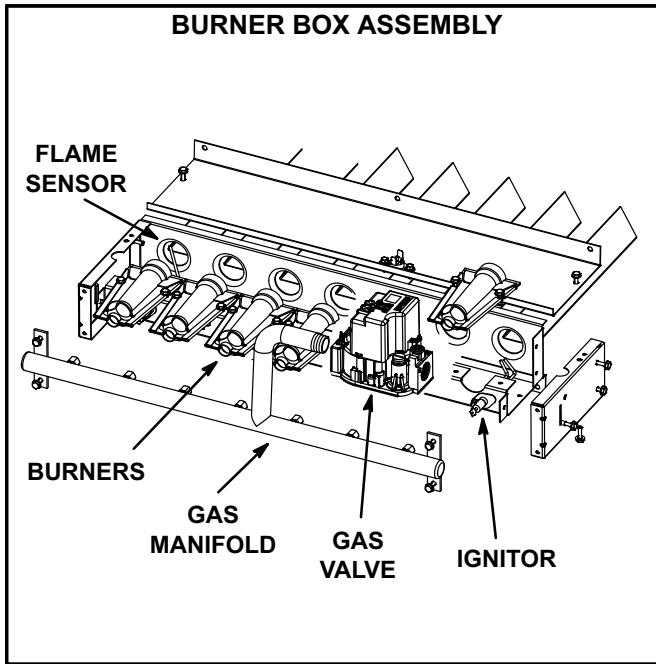

**FIGURE 19**

- Locate the ignitor under the right burner. Check ignitor spark gap with appropriately sized twist drills or feeler gauges. See figure 20.

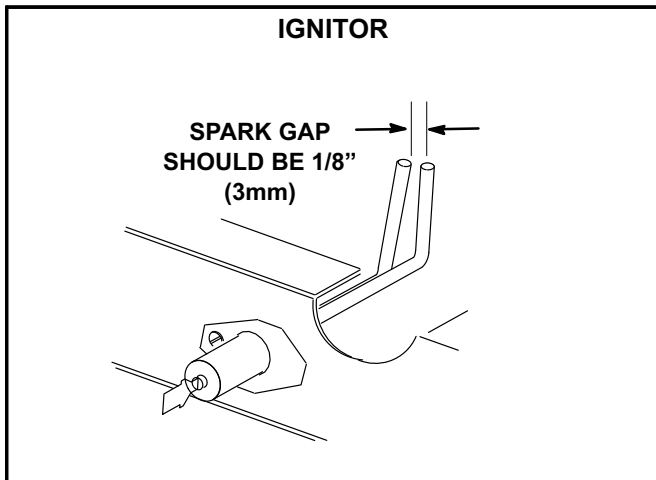

**FIGURE 20**

- Replace burners and screws securing burner. See figure 21.

**⚠ WARNING**

**Danger of explosion. Can cause injury or death. Do not overtighten main burner mounting screws. Snug tighten only.**

- Replace access panel.
- Restore electrical power and gas supply. Follow lighting instructions attached to unit and use inspection port in access panel to check flame.

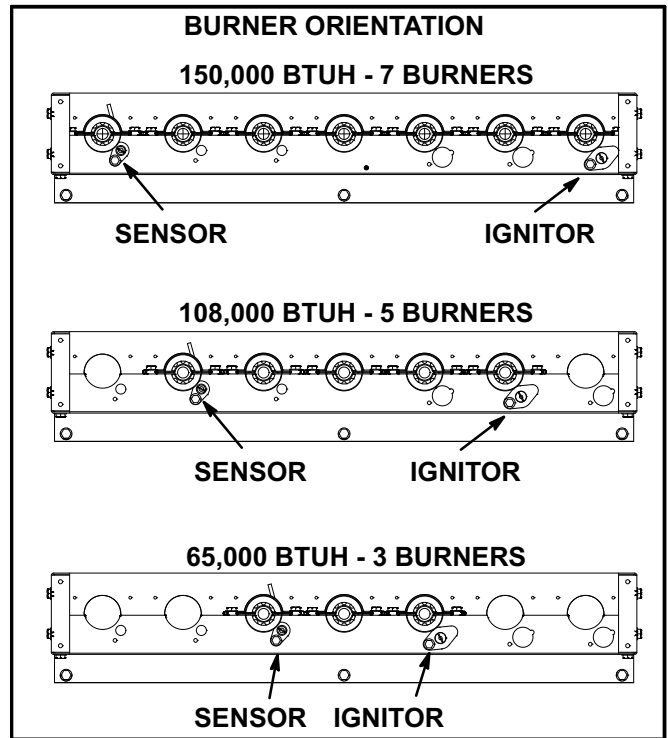

**FIGURE 21**

**D-Combustion Air Inducer (Gas Units)**

A combustion air proving switch checks combustion air inducer operation before allowing power to the gas controller. Gas controller will not operate if inducer is obstructed.

Under normal operating conditions, the combustion air inducer wheel should be checked and cleaned prior to the heating season. However, it should be examined periodically during the heating season to establish an ideal cleaning schedule.

Clean combustion air inducer as follows:

- Shut off power supply and gas to unit.
- Remove the access panel located on the right side of the outdoor section under the control box.
- Remove and retain screws securing combustion air inducer to flue box. Remove vent connector. See figure 22.

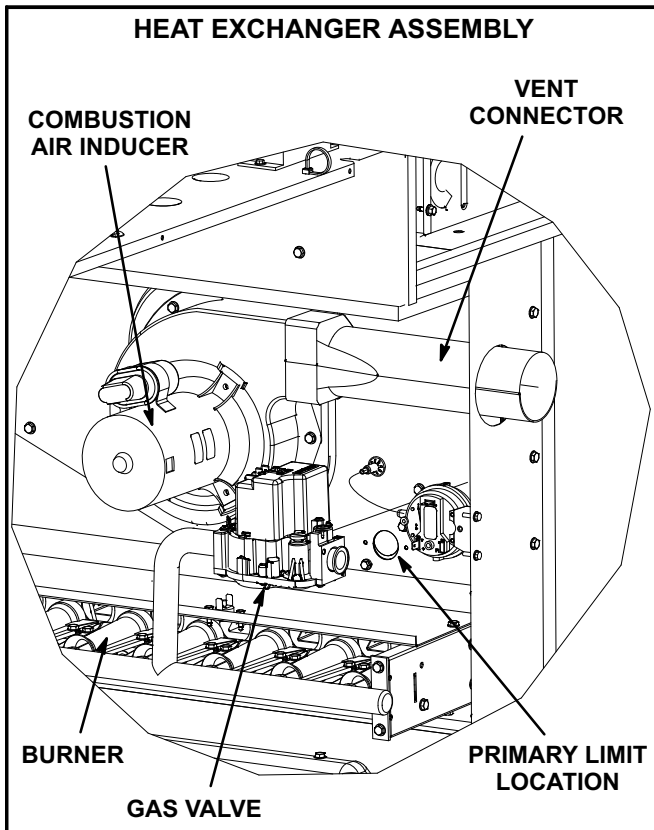

**FIGURE 22**

- 4- Clean inducer wheel blades with a small brush and wipe off any dust from housing. Take care not to damage exposed fan blades. Clean accumulated dust from front of flue box cover.
- 5- Return combustion air inducer motor and vent connector to original location and secure with retained screws. It is recommended that gaskets be replaced during reassembly.
- 6- Replace the access panel.
- 7- Clean combustion air inlet louvers on heat access panel using a small brush.

### **E-Flue Box (Gas Units)**

Remove flue box cover only when necessary for equipment repair. Clean inside of flue box cover and heat exchanger tubes with a wire brush when flue box cover has to be removed. Install a new flue box cover gasket and replace cover. Make sure edges around flue box cover are tightly sealed.

### **F-Evaporator Coil**

Inspect and clean coil at beginning of each cooling season. Clean using mild detergent or commercial coil cleaner. Flush coil and condensate drain with water taking care not to get insulation, filters and return air ducts wet.

### **G-Condenser Coil**

Clean condenser coil annually with water and inspect monthly during the cooling season.

Clean the all-aluminum coil by spraying the coil steadily and uniformly from top to bottom. Do not exceed 900 psi or a 45 degree angle; nozzle must be at least 12 inches from the coil face. Take care not to fracture the braze between the fins and refrigerant tubes. Reduce pressure and work cautiously to prevent damage.

### **H-Compressor**

If Interlink compressor replacement is necessary, call 1-800-4-LENNOX (1-800-453-6669).

## **⚠ IMPORTANT**

**Some scroll compressors have an internal vacuum protector that will unload scrolls when suction pressure goes below 20 psig. A hissing sound will be heard when the compressor is running unloaded. Protector will reset when low pressure in system rises above 40 psig. DO NOT REPLACE COMPRESSOR.**

### **J-Supply Air Blower Wheel**

Annually inspect supply air blower wheel for accumulated dirt or dust. Turn off power before attempting to remove access panel or to clean blower wheel.