

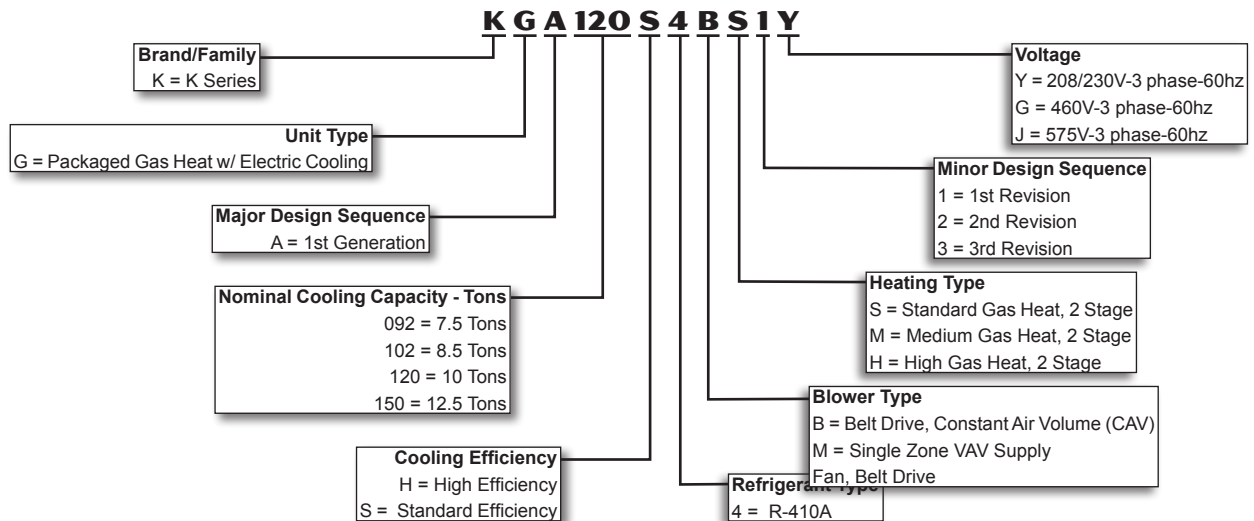

**ASHRAE 90.1
COMPLIANT**

7.5 to 12.5 Tons
Net Cooling Capacity – 86,000 to 138,000 Btuh
Gas Input Heat Capacity – 130,000 to 240,000 Btuh

MODEL NUMBER IDENTIFICATION



FEATURES AND BENEFITS

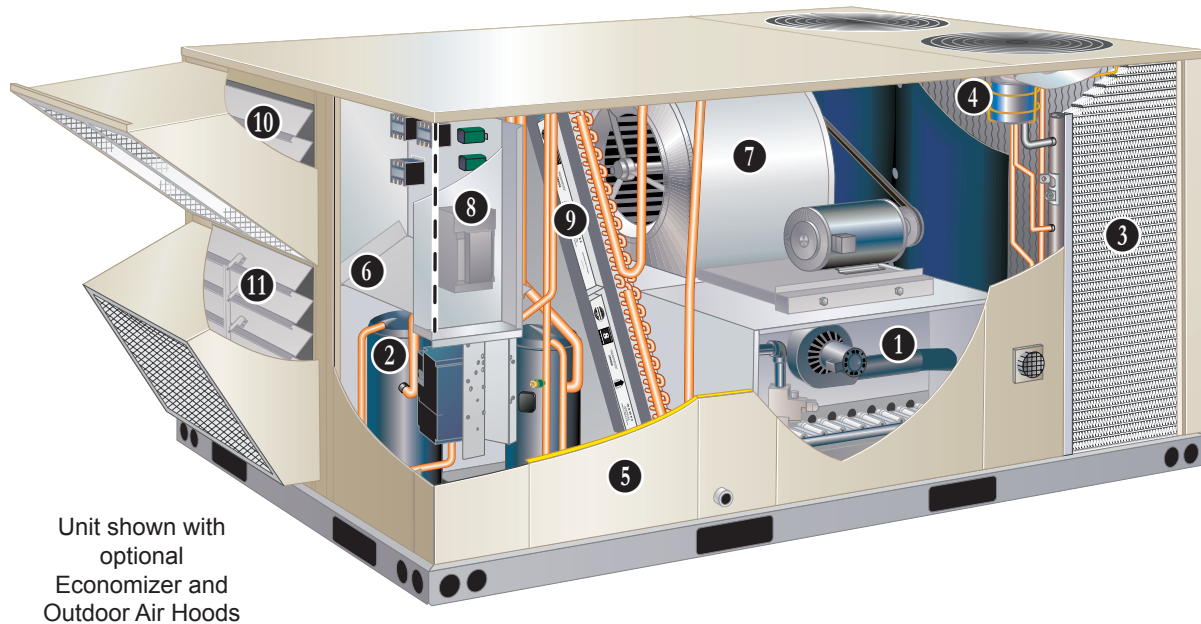

K-Series™ rooftop units from Allied are the new standard for reliable, efficient rooftop units built for long-lasting performance that can significantly improve indoor environments. K-Series™ rooftop units feature:

- **Aluminized Steel Heat Exchanger With Inshot Burners** - Life cycle tested.
- **R-410A Refrigerant** - Environmentally friendly.
- **Scroll Compressors** - Single speed scroll compressors are furnished on all models.
- **Eco-last™ Coil System** - Smaller, lighter condenser coil.
- **High Pressure Switches** - Protect compressor.
- **Isolated Compressor Compartment** - Allows performance check during normal compressor operation without disrupting airflow.
- **Independent Outdoor Fan Motor Mounts** - Allows for easy and efficient service access without removing the top panel.
- **Constant Air Volume (CAV) or Single Zone VAV Supply Fan Blower Option** - Allows constant or multi-staged air delivery.
- **Downflow or Horizontal Airflow** - Easy field conversion.
- **Two Fork Lift Slots on Three Sides** - Easy to pick up and transport units from almost any angle.
- **Corrosion-Resistant Removable, Reversible Drain Pan** - Provides application flexibility, durability and improved serviceability.
- **Thermostatic Expansion Valves** - Provide peak cooling performance across the entire application range.
- **MERV 8 or MERV 13 Filters** - Available as field installed option, provide an enhanced level of indoor air quality, and can help the building qualify for additional LEED credits.
- **Common Components** - Many maintenance items are standard throughout the entire product line, reducing the need to carry different parts to the job or maintain in inventory.

FEATURES AND BENEFITS

CONTENTS

Blower Data26
Dimensions - Accessories.40
Dimensions - Unit39
Electrical Data.32
Features And Benefits	2
Model Number Identification	1
Options / Accessories10
Outdoor Sound Data37
Ratings18
Specifications13
Unit Clearances.36
Weight Data.38

APPROVALS

AHRI Certified to AHRI Standard 340/360-2007.

Units are ETL listed.

Units are certified by CSA.

Components bonded for grounding to meet safety standards for servicing required by UL, ULC and National and Canadian Electrical Codes.

All models are ASHRAE 90.1-2010 energy efficiency compliant and meet or exceed requirements of Section 6.8.

Models equipped with the Single Zone VAV Supply Fan option meet California Code of Regulations, Title 24 and ASHRAE 90.1-2010 Section 6.4.3.10 requirements for staged airflow.

ISO 9001 Registered Manufacturing Quality System.

WARRANTY

Limited ten years aluminized heat exchanger, limited fifteen years optional stainless steel heat exchanger.

Limited five years on compressors.

Limited three years on the Eco-last™ Coil System.

Limited five years Optional High Performance Economizers.

Limited one year all other covered components.

HEATING SYSTEM

Aluminized steel inshot burners, direct spark ignition, electronic flame sensor, combustion air inducer, redundant automatic dual stage gas valve with manual shut-off.

① Heat Exchanger

Tubular construction, aluminized steel, life cycle tested.

Optional Stainless Steel Heat Exchanger is required if mixed air temperature is below 45°F.

Electronic Pilot Ignition

Electronic spark igniter provides positive direct ignition of burners on each operating cycle. The system permits main gas valve to stay open only when the burners are proven to be lit. Should a loss of flame occur, the gas valve closes, shutting off the gas to the burners. Ignition module has LED to indicate status and aid in troubleshooting.

Watchguard circuit on module automatically resets ignition controls after one hour of continuous thermostat demand after unit lockout, eliminating nuisance service calls.

Ignition control is factory installed in the controls section.

Limit Control

Factory installed, limit control with fixed temperature setting. Heat limit control protects heat exchanger and other components from overheating.

Safety Switches

Flame roll-out switch, flame sensor and combustion air inducer proving switch protect system operation.

Required Selections

Gas Input Choice - Order one:

Standard Gas Heat, 2 Stage (84,500/130,000 Btuh)

Medium Gas Heat, 2 Stage (117,000/180,000 Btuh)

High Gas Heat, 2 Stage (156,000/240,000 Btuh)

Options/Accessories

Factory Installed

Stainless Steel Heat Exchanger
Required if mixed air temperature is below 45°F.

Field Installed

Bottom Gas Piping Kit
Allows bottom gas entry.

Combustion Air Intake Extensions

Recommended for use with existing flue extension kits in areas where high snow areas can block intake air.

Low Temperature Vestibule Heater

Electric heater automatically controls minimum temperature in gas burner compartment when temperature is below -40°F. CSA certified to allow operation of unit down to -60°F.

LPG/Propane Kits

Conversion kit to field change over units from Natural Gas to LPG/Propane.

FEATURES AND BENEFITS

HEATING SYSTEM (continued)

Options/Accessories

Field Installed

Vertical Vent Extension Kit

Use to exhaust flue gases vertically above unit. Required when unit vent is too close to fresh air intakes per building codes. The vent kit also prevents ice formation on intake louvers.

Kit contains vent transition, vent tee, drain cap and installation hardware.

NOTE - Straight vent pipes (4 in. B-Vent) and caps are not furnished and must be field supplied. Refer to kit instructions for additional information.

COOLING SYSTEM

Designed to maximize sensible and latent cooling performance at design conditions.

System can operate from 30°F to 125°F without any additional controls.

R-410A Refrigerant Non-chlorine based, ozone friendly, R-410A.

2 Scroll Compressors

Scroll compressors on all models for high performance, reliability and quiet operation.

Resiliently mounted on rubber grommets for quiet operation.

Compressor Crankcase Heaters

Protects against refrigerant migration that can occur during low ambient operation.

Thermal Expansion Valves (High Efficiency Models)

Assures optimal performance throughout the application range.

Removable element head.

Refrigerant Metering Orifice (Standard Efficiency Models)

Accurately meters refrigerant in system.

Refrigerant control is accomplished by exact sizing of refrigerant metering orifice.

Filter/Driers

High capacity filter/drier protects

the system from dirt and moisture.

High Pressure Switches

Protects the compressor from overload conditions such as dirty condenser coils, blocked refrigerant flow, or loss of outdoor fan operation. Auto reset.

Freezestats

Protects the evaporator coil from damaging ice build-up due to conditions such as low/no airflow, or low refrigerant charge.

3 Eco-last™ Coil System

Condenser coil features lightweight, all aluminum brazed fin construction.

Constructed of three components: a flat extrusion tube, fins in-between the flat extrusion tube and two refrigerant manifolds.

Eco-last™ Coil System Features:

- Improved heat transfer performance due to high primary surface area (flat tubes) versus secondary surface (fins).
- Smaller internal volume (reduced refrigerant charge).
- High durability (all aluminum construction).
- Fewer brazed joints.
- Compact design (reduces unit weight).
- Easy maintenance/cleaning.

Face-split design.

Mounting brackets with rubber inserts secure coil to unit providing vibration dampening and corrosion protection.

Evaporator Coil

Copper tube construction, enhanced rippled-edge aluminum fins, flared shoulder tubing connections, silver soldered construction for improved heat transfer.

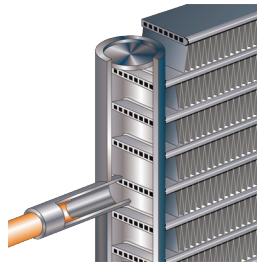

Cross row circuiting with rifled copper tubing optimizes both sensible and latent cooling capacity.

Condensate Drain Pan

Plastic pan, sloped to meet drainage requirements of ASHRAE 62.1.

Side or bottom drain connections.

Reversible to allow connection at back of unit.

Outdoor Coil Fan Motors

Thermal overload protected, totally enclosed, permanently lubricated ball bearings, shaft up, wire basket mount.

4 Outdoor Coil Fans

PVC coated fan guard furnished.

Required Selections

Cooling Capacity

Specify nominal cooling capacity of the unit

Cooling Efficiency

Specify either standard or high efficiency.

Options/Accessories

Field Installed

Condensate Drain Trap

Available in copper or PVC.

Drain Pan Overflow Switch

Monitors condensate level in drain pan, shuts down unit if drain becomes clogged.

Low Ambient Kit

Cycles the outdoor fans while allowing compressor operation in the cooling cycle. This intermittent fan operation allows the system to operate without icing the evaporator coil and losing capacity. Designed for use in ambient temperatures no lower than 0°F. Low Ambient Kit also controls the compressor crankcase heaters.

FEATURES AND BENEFITS

CONTROLS

5 Unit Control

All control voltage is provided via a 24V (secondary) transformer with built-in circuit breaker protection.

Heat/Cool Staging - Capable of up to 2 heat / 2 cool staging with a third party DDC control system or thermostat.

Low Voltage Terminal Block - Provides screw terminal connections for thermostat or controller wiring.

Night Setback Mode - Saves energy by closing outdoor air dampers and operating supply fan on thermostat demand only.

Options/Accessories

Field Installed

Smoke Detector

Photoelectric type, installed in supply air section, return air section or both sections. Available with power board and single sensor (supply or return) or power board and two sensors (supply and return).

CABINET

6 Construction

Heavy-gauge steel panels and full perimeter heavy-gauge galvanized steel base rail provides structural integrity for transportation, handling, and installation.

Base rails have rigging holes.

Three sides of the base rail have forklift slots.

Raised edges around duct and power entry openings in the bottom of the unit provide additional protection against water entering the building.

Airflow Choice

Units are shipped in downflow (vertical) configuration, can be field converted to horizontal airflow with optional Horizontal Discharge Kit.

Duct Flanges

Provided for horizontal duct attachment.

Power/Gas Entry

Electrical and gas lines can be brought through the unit base or through horizontal access knock-outs

Exterior Panels

Constructed of heavy-gauge, galvanized steel with a two-layer enamel paint finish.

Insulation

All panels adjacent to conditioned air are fully insulated with non-hygroscopic fiberglass insulation.

Unit base is fully insulated. The insulation also serves as an air seal to the roof curb, eliminating the need to add a seal during installation.

Access Panels

Access panels are provided for the filter section, heating/blower section, and the compressor/controls section.

Options/Accessories

Factory Installed

Corrosion Protection

A completely flexible immersed coating with an electrodeposited dry film process. (AST ElectroFin

E-Coat) Meets Mil Spec MIL-P-53084, ASTM B117 Standard Method Salt Spray Testing.

Indoor Corrosion Protection:

- Coated coil
- Painted blower housing
- Painted base

Outdoor Corrosion Protection:

- Coated coil
- Painted base

Hinged Access Panels

Large access panels are hinged and have quarter-turn latches for quick and easy access to maintenance areas (filter, compressor / controls, heating / blower).

Field Installed

Coil Guards

Painted, galvanized steel wire guards to protect outdoor coil.

Not used with Hail Guards.

Hail Guards

Constructed of heavy gauge steel, painted to match cabinet, helps protect outdoor coils from hail damage.

Not used with Coil Guards.

Horizontal Discharge Kit

Consists of duct covers to block off downflow supply and return air openings for horizontal applications.

Also includes return air duct flanges for end return air when economizer is used in horizontal applications.

NOTE - When configuring unit for horizontal application with economizer, a separate Horizontal Barometric Relief Damper with Hood must be ordered separately for installation in the return air duct.

FEATURES AND BENEFITS

7 BLOWER

A wide selection of supply air blower options are available to meet a variety of airflow requirements.

Motor

Overload protected, equipped with ball bearings. Belt drive motors are offered on all models and are available in several different sizes to maximize air performance.

Supply Air Blower

Forward curved blades, double inlet, blower wheel is statically and dynamically balanced. Equipped with ball bearings and adjustable pulley (allows speed change).

Blower assembly slides out of unit for servicing.

Required Selections

Select Constant Air Volume (CAV) or Single Zone VAV Supply Fan Supply Air Blower Option

Order blower motor horsepower and drive kit number required when base unit is ordered, see Drive Kit Specifications Table.

CAV Operation

On units ordered with the Constant Air volume (CAV) option, the supply air blower will provide a constant volume of air.

Single Zone VAV Supply Fan Operation

Units ordered with the Single Zone VAV Supply Fan option utilize a Variable Frequency Drive (VFD) to stage the supply air blower airflow. The VFD alters the frequency and voltage of the power supply to the blower to control blower speed.

The supply air blower has two speeds:

1. Low speed for part-load cooling operation. Note - Low speed is 66% of high speed.
2. High speed for full load cooling and all heat modes.

Full speed blower operation is set by adjusting the motor pulley to deliver the desired air volume. The ventilation speed is selectable between high and low speed.

NOTE - Part load airflow in cooling mode on Single Zone VAV Supply Fan units should not be set below 220 cfm/nominal full load ton to reduce the risk of evaporator coil freeze-up.

The VFD has an operational range of -40 to 125° F outdoor air ambient temperature.

Lower operating costs are obtained when the blower is operated on lower speeds.

Single Zone VAV Supply Fan Sequence of Operation

Ventilation speed is determined by the VENT SPEED switch setting on VFD control board (LO or HI).

Blower operates in low speed for mechanical cooling (Y1).

Blower operates in high speed for any other mode (free cooling, mechanical cooling Y1+Y2, and heating).

Economizer damper minimum position is fully closed in unoccupied mode.

In occupied mode, the economizer damper minimum position is determined by the setting of the two potentiometers on VFD control board.

- LO SPD MIN POS potentiometer sets the minimum position when blower is operating at low speed.
- HI SPD MIN POS potentiometer sets the minimum position when blower is operating at high speed.

Options/Accessories

Field Installed

VFD Manual Bypass Kit

VFD Manual Bypass Control is available as a kit for units equipped with the Single Zone VAV Supply Fan option.

The VFD Manual Bypass Control is a manual bypass and is enabled by re-configuring the wiring on the unit.

ELECTRICAL

Marked & Color-Coded Wiring

All electrical wiring is color-coded and marked to identify which components it is connecting.

Electrical Plugs

Positive connection electrical plugs are used to connect common accessories or maintenance parts for easy removal or installation.

Phase Monitor (Factory Installed on Units Equipped with the Single Zone VAV Supply Fan)

Phase monitor located in the control compartment detects the phasing of incoming power. If the incoming power is out of phase or if any of the three phases are lost, an indicator LED on the phase monitor will turn red and the unit will not start. In normal operation with correct incoming power phasing, the LED will be green.

Required Selections

Voltage Choice

Specify when ordering base unit.

Options/Accessories

Factory or Field Installed

8 Disconnect Switch

Accessible from outside of unit, spring loaded weatherproof cover furnished. Main power to the unit is field connected to the disconnect which allows all power to be shut off for service. See Options/Accessories tables for ordering information, page 37.

GFI Service Outlets (2)

115V ground fault circuit interrupter (GFCI) type, non-powered, field-wired.

Field Installed

GFI Weatherproof Cover

Single-gang cover.

Heavy-duty UV-resistant polycarbonate case construction. Hinged base cover with gasket.

FEATURES AND BENEFITS

INDOOR AIR QUALITY

9 Air Filters

Disposable 2 inch filters furnished as standard.

Options/Accessories

Field Installed

High Efficiency Air Filters

Disposable MERV 8 or MERV 13 (Minimum Efficiency Reporting Value based on ASHRAE 52.2) efficiency 2 inch pleated filters.

Replacement Filter Media Kit With Frame

Replaces existing pleated filter media. Includes washable metal mesh screen and metal frame with clip for holding replaceable non-pleated filter.

UVC Germicidal Lamps

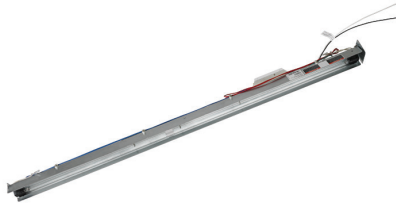

Germicidal lamps emit ultra-violet (UV-C) energy, which has been proven to be effective in reducing microbes such as viruses, bacteria, yeasts, and molds. This process either destroys the organism or controls its ability to reproduce.

UV-C energy greatly reduces the growth and proliferation of mold and other bioaerosols (bacteria and viruses) on illuminated surfaces (particularly coil and drain pan).

Lamps are field installed in the blower/evaporator coil section.

All necessary hardware for installation is included.

Lamps operate on 208/230V power supply. Step-down transformer must be field supplied when used with 460V and 575V rooftop units.

Magnetic safety interlock terminates power when access panels are removed.

Approved by ETL.

Indoor Air Quality (CO₂) Sensors

Monitors CO₂ levels, reports to the Unit Controller which adjusts economizer dampers as needed.

ECONOMIZER OPTIONS

Factory or Field Installed

**10 Economizer
(Standard and High Performance
Common Features)**

Downflow or Horizontal with Outdoor Air Hood and Barometric Relief Dampers with Exhaust Hood.

11 Barometric Relief Dampers allow relief of excess air, aluminum blade dampers prevent blow back and outdoor air infiltration during off cycle, bird screen furnished.

NOTE - Optional Horizontal Low Profile Barometric Relief Dampers with Exhaust Hood are available for field installation in a reduced space.

Occupied/Unoccupied mode with field furnished setback thermostat.

Demand Control Ventilation (DCV) ready using optional CO₂ sensors.

Mixed Air Sensor is furnished for field installation in the rooftop unit. Sensor is factory installed when Economizers are factory installed.

Single sensible sensor is furnished with Economizer and enables economizer operation if the outdoor temperature is less than the setpoint of the control.

**Standard Economizer Features
(Not for Title 24)**

Parallel, gear-driven action, return air and outdoor air dampers, plug-in connections to unit, nylon bearings, neoprene seals, 24-volt, fully-modulating spring return motor.

**Standard Economizer
Control Module**

The Standard Economizer Control Module can be adjusted to operate based on outdoor air temperatures.



Economizer Controls:

- Damper Minimum Position - Can be set lower than traditional minimum air requirements resulting in cost savings.

- IAQ Sensor - Signals dampers to modulate and maintain 55°F when CO₂ is higher than the CO₂ setpoint.
- Demand Control Ventilation (DCV) LED - A steady green Demand Control Ventilation LED indicates the IAQ reading is higher than setpoint and requires more fresh air.
- Free Cool LED - A steady green LED indicates outdoor air is suitable for free cooling.

Free Cooling runs when outdoor air temperature is lower than the set temperature on the economizer control.

NOTE: The Free Cooling default setting for outdoor air temperature sensor is 55°F.

**High Performance
Economizer Features**

Approved for California Title 24 building standards.

ASHRAE 90.1-2010 compliant.

Gear-driven action, high torque 24-volt fully-modulating spring return damper motor, return air and outdoor air dampers, plug-in connections to unit, stainless steel bearings, enhanced neoprene blade edge seals and flexible stainless steel jamb seals to minimize air leakage.

NOTE - High Performance Economizers are not approved for use with enthalpy controls in Title 24 applications.

**High Performance
Economizer Control Module**

Module provides inputs and outputs to control economizer based on parameter settings. Module automatically detects sensors by polling to determine which sensors are installed in system.



Module displays any alarm messages (fault detection and diagnostics) as an aid in troubleshooting.

Non-volatile memory retains parameter settings in case of power failure.

Keypad with four navigation buttons and LCD screen is furnished for setting economizer parameters.

- Menu Up/Exit (↑) button returns to the main menu.
- Arrow Up (▲) button moves to the previous or next parameter within the selected menu.
- Arrow Down (▼) button moves to the next parameter within the selected menu.
- Select (enter) (↵) button confirms parameter selection.

Main Menu Structure:

- STATUS (economizer and system operation status)
- SETPOINTS (settings for various setpoint parameters)
- SYSTEM SETUP (settings/information about the system)
- ADVANCED SETUP (freeze protection, CO₂ settings, stage 3 delay and additional calibration settings)
- CHECKOUT (damper positions)
- ALARMS (output signal that can be configured for remote alarm monitoring)

NOTE - The Free Cooling setpoint for Title 24 applications must be set based on the Climate Zone where the system is installed. See Section 140.4 "Prescriptive Requirements for Space Conditioning Systems" of the California Energy Commission's 2013 Building Energy Efficiency Standards.

Refer to Installation Instructions for complete setup information and menu parameters available.

ECONOMIZER OPTIONS
(continued)**Factory or Field Installed****Single Enthalpy Temperature Control****(Not for Title 24)**

Outdoor air enthalpy sensor enables Economizer if the outdoor enthalpy is less than the setpoint of the control.

Field Installed**Differential Enthalpy Control (Not for Title 24)**

Order two Single Enthalpy Controls. One is field installed in the return air section, the other in the outdoor air section. Allows the economizer control board to select between outdoor air or return air, whichever has lower enthalpy.

EXHAUST OPTIONS**Field Installed****Horizontal Low Profile****Barometric Relief Dampers**

Replaces barometric relief dampers furnished with Economizer.

For use when unit is configured for horizontal applications in a reduced space requiring an economizer.

Allows relief of excess air.

Aluminum blade dampers prevent blow back and outdoor air infiltration during off cycle.

Field installed in return air duct.

Exhaust hood with bird screen furnished.

Requires Horizontal Discharge Kit.

Power Exhaust Fan

Installs internal to unit for downflow applications only with economizer option. Provides exhaust air pressure relief. Interlocked to run when supply air blower is operating, fan runs when outdoor air dampers are 50% open (adjustable), motor is overload protected. Requires Economizer with Outdoor Air Hood and Barometric Relief Dampers. Fan is 20 in. diameter with 5 blades (K1PWRE10B) WITH 1/3 hp motor.

OUTDOOR AIR OPTIONS**Factory or Field Installed****Outdoor Air Damper - Downflow or Horizontal With Air Hood**

Linked mechanical dampers, 0 to 25% (fixed) outdoor air adjustable, installs in unit. Includes outdoor air hood.

Automatic model features fully modulating spring return damper motor with plug-in connection.

Manual model features a slide damper.

Maximum mixed air temperature in cooling mode: 100°F.

ROOF CURBS

Nailer strip furnished, mates to unit, US National Roofing Contractors Approved, shipped knocked down.

Hybrid Roof Curbs, Downflow

Roof curb can be assembled using interlocking tabs to fasten corners together. No tools required.

Curb can also be fastened together with furnished hardware.

Available in 8, 14, 18, and 24 inch heights.

Adjustable Pitch Curb

Fully adjustable pitch curbs (3/4 in. per foot in any direction) provide a level platform for rooftop units allowing flexible installations on roofs with uneven or sloped angles.

Uses interlocking tabs to fasten corners together. No tools required.

Hardware is furnished to connect upper curb with lower curb.

Available in 14 inch height

Adaptor Curbs (not shown)

Curbs are regionally sourced. Dimensions will vary based upon the source. Contact your local sales representative for a detailed cut sheet with applicable dimensions.

CEILING DIFFUSERS**Ceiling Diffusers****(Flush or Step-Down)**

Aluminum grilles, large center grille, insulated diffuser box with flanges, hanging rings furnished, interior transition (even air flow), internally sealed (prevents recirculation), adapts to T-bar ceiling grids or plaster ceilings.

Transitions (Supply and Return)

Used with diffusers, installs in roof curb, galvanized steel construction, flanges furnished for duct connection to diffusers, fully insulated.

OPTIONS / ACCESSORIES

Item Description	Model Number	Catalog Number	Unit Model No			
			092	102	120	150
COOLING SYSTEM						
Condensate Drain Trap	PVC - C1TRAP20AD2	76W26	X	X	X	X
	Copper - C1TRAP10AD2	76W27	X	X	X	X
Corrosion Protection		Factory	O	O	O	O
Drain Pan Overflow Switch	K1SNSR71AB1-	74W42	X	X	X	X
Efficiency		High	O	O	O	O
		Standard	O	O	O	O
Low Ambient Kit	K1SNSR33B-1	54W16	X	X	X	X
Refrigerant Type		R-410A	O	O	O	O
HEATING SYSTEM						
Bottom Gas Piping Kit	C1GPKT01B-01	54W95	X	X	X	X
Combustion Air Intake Extensions	T1EXTN10AN1	19W51	X	X	X	X
Gas Heat Input	130,000 Btuh	Factory	O	O	O	O
	180,000 Btuh	Factory	O	O	O	O
	240,000 Btuh	Factory	O	O	O	O
Low Temperature Vestibule Heater	208/230V-3ph - C1LTVH10B-1Y	55W91	X	X	X	X
	460V - C1LTVH10B-1G	55W92	X	X	X	X
	575V - C1LTVH10B-1J	55W93	X	X	X	X
LPG/Propane Conversion Kits	Standard Heat - E1LPCO10B-1	53W07	X	X	X	X
	Medium Heat - E1LPCO20B-1	53W08	X	X	X	X
	High Heat - E1LPCO30B-1	53W09	X	X	X	X
Stainless Steel Heat Exchanger		Factory	O	O	O	O
Vertical Vent Extension	C1EXTN2021	42W16	X	X	X	X
BLOWER - SUPPLY AIR						
Blower Option	CAV (Constant Air Volume)	Factory	O	O	O	O
	Single Zone VAV Supply Fan	Factory	O	O	O	O
Blower Motors	Belt Drive - 2 hp	Factory	O	O	O	O
	Belt Drive - 3 hp	Factory	O	O	O	O
	Belt Drive - 5 hp	Factory	O	O	O	O
VFD Manual Bypass Kit (for Single Zone VAV Supply Fan equipped units only)	KVFDB12C-1	90W53	X	X	X	X
Drive Kits	Kit #1 590-890 rpm	Factory	O	O	O	O
See Blower Data Tables for selection	Kit #2 800-1105 rpm	Factory	O	O	O	O
	Kit #3 795-1195 rpm	Factory	O	O	O	O
	Kit #4 730-970 rpm	Factory	O	O	O	O
	Kit #5 940-1200 rpm	Factory	O	O	O	O
	Kit #6 1015-1300 rpm	Factory	O	O	O	O
	Kit #10 900-1135 rpm	Factory	O	O	O	O
	Kit #11 1040-1315 rpm	Factory	O	O	O	O
	Kit #12 1125-1425 rpm	Factory	O	O	O	O
	CABINET					
	Coil Guards	E1GARD21B-1	92W62	X	X	X
Hail Guards	E1GARD11B-1	92W61	X	X	X	X
Hinged Access Panels		Factory	O	O	O	O
Horizontal Discharge Kit	K1HECK00B-1	51W25	X	X	X	X

NOTE - Catalog and model numbers shown are for ordering field installed accessories.

OX - Configure To Order (Factory Installed) or Field Installed

O = Configure To Order (Factory Installed)

X = Field Installed

OPTIONS / ACCESSORIES

Item Description	Model Number	Catalog Number	Unit Model No			
			092	102	120	150
CONTROLS						
Commercial Controls						
BACnet®	K0CTRL31B-1	96W15	OX	OX	OX	OX
BACnet® Thermostat with Display	K0SNSR01FF1	97W23	X	X	X	X
BACnet® Thermostat without Display	K0SNSR00FF1	97W24	X	X	X	X
Novar® 2051	K0CTRL30B-1	96W12	OX	OX	OX	OX
Plenum Cable (75 ft.)	K0MISC00FF1	97W25	X	X	X	X
Smoke Detector - Supply or Return (Power board and one sensor)	C1SNSR44B-2	11K76	X	X	X	X
Smoke Detector - Supply and Return (Power board and two sensors)	C1SNSR43B-2	11K80	X	X	X	X
INDOOR AIR QUALITY						
Air Filters						
High Efficiency Air Filters	MERV 8 - C1FLTR15B-1	50W61	X	X	X	X
20 x 25 x 2 (Order 4 per unit)	MERV 13 - C1FLTR40B-1	52W41	X	X	X	X
Replacement Media Filter With Metal Mesh Frame (includes non-pleated filter media)	C1FLTR30B-1-	Y3063	X	X	X	X
Indoor Air Quality (CO₂) Sensors						
Sensor - Wall-mount, off-white plastic cover with LCD display	C0SNSR50AE1L	77N39	X	X	X	X
Sensor - Wall-mount, off-white plastic cover, no display	C0SNSR52AE1L	87N53	X	X	X	X
Sensor - Black plastic case with LCD display, rated for plenum mounting	C0SNSR51AE1L	87N52	X	X	X	X
Sensor - Wall-mount, black plastic case, no display, rated for plenum mounting	C0MISC19AE1	87N54	X	X	X	X
CO ₂ Sensor Duct Mounting Kit - for downflow applications	C0MISC19AE1-	85L43	X	X	X	X
Aspiration Box - for duct mounting non-plenum rated CO ₂ sensors (87N53 or 77N39)	C0MISC16AE1-	90N43	X	X	X	X
UVC Germicidal Lamps						
¹ UVC Light Kit (208/230v-1ph)	C1UVCL10B-1	54W62	X	X	X	X
ELECTRICAL						
Voltage 60 hz	208/230V - 3 phase	Factory	O	O	O	O
	460V - 3 phase	Factory	O	O	O	O
	575V - 3 phase	Factory	O	O	O	O
Disconnect Switch - See Electrical/Electric Heat tables for selection	80 amp - C1DISC080B-1	54W56	OX	OX	OX	OX
	150 amp - C1DISC150B-1	54W57	OX	OX	OX	OX
GFI Service Outlets	15 amp non-powered, field-wired (208/230V, 460V only)	LTAGFIK10/15	74M70	OX	OX	OX
	20 amp non-powered, field-wired (575V only)	C1GFIC120FF1	67E01	X	X	X
Weatherproof Cover for GFI	C1GFIC199FF1	10C89	X	X	X	X

¹ Lamps operate on 110-230V single-phase power supply. Step-down transformer may be ordered separately for 460V and 575V units. Alternately, 110V power supply may be used to directly power the UVC ballast(s)

NOTE - Catalog and model numbers shown are for ordering field installed accessories.

OX - Configure To Order (Factory Installed) or Field Installed

O = Configure To Order (Factory Installed)

X = Field Installed

OPTIONS / ACCESSORIES

Item Description	Model Number	Catalog Number	Unit Model No			
			092	102	120	150
ECONOMIZER						
Standard Economizer (Not for Title 24)						
Standard Economizer with Single Temperature Control Downflow or Horizontal Applications - Includes Barometric Relief Dampers and Air Hoods	K1ECON20B-1	54W55	OX	OX	OX	OX
Standard Economizer Controls (Not for Title 24)						
Single Enthalpy Control	C1SNSR64FF1	53W64	OX	OX	OX	OX
Differential Enthalpy Control (order 2)	C1SNSR64FF1	53W64	X	X	X	X
High Performance Economizer (Approved for California Title 24 Building Standards)						
High Performance Economizer with Single Temperature Control Downflow or Horizontal Applications - Includes Barometric Relief Dampers and Air Hoods	K1ECON22B-1	10U58	OX	OX	OX	OX
High Performance Economizer Controls (Not for Title 24)						
Single Enthalpy Control	C1SNSR60FF1	10Z75	OX	OX	OX	OX
Differential Enthalpy Control (order 2)	C1SNSR60FF1	10Z75	X	X	X	X
Horizontal Low Profile Barometric Relief Dampers With Exhaust Hood						
Horizontal Low Profile Barometric Relief Dampers With Exhaust Hood	LAGEDH03/15	53K04	X	X	X	X
OUTDOOR AIR						
Outdoor Air Dampers With Outdoor Air Hood						
Motorized	C1DAMP20B-1	53W49	OX	OX	OX	OX
Manual	C1DAMP10B-1	53W48	OX	OX	OX	OX
POWER EXHAUST						
Standard Static	208/230V-3ph - K1PWRE10B-1Y	53W44	X	X	X	X
	460V-3ph - K1PWRE10B-1G	53W45	X	X	X	X
	575V-3ph - K1PWRE10B-1J	53W46	X	X	X	X
ROOF CURBS						
Hybrid Roof Curbs, Downflow						
8 in. height	C1CURB70B-1	11F54	X	X	X	X
14 in. height	C1CURB71B-1	11F55	X	X	X	X
18 in. height	C1CURB72B-1	11F56	X	X	X	X
24 in. height	C1CURB73B-1	11F57	X	X	X	X
Adjustable Pitch Curb						
14 in. height	C1CURB55B-1	54W50	X	X	X	X
CEILING DIFFUSERS						
Step-Down - Order one	RTD11-95	29G04	X			
	RTD11-135	29G05		X	X	
	RTD11-185	29G06				X
Flush - Order one	FD11-95	29G08	X			
	FD11-135	29G09		X	X	
	FD11-185	29G10				X
Transitions (Supply and Return) - Order one	C1DIFF30B-1	12X65	X			
	C1DIFF31B-1	12X66		X	X	
	C1DIFF32B-1	12X67				X

NOTE - Catalog and model numbers shown are for ordering field installed accessories.

OX - Configure To Order (Factory Installed) or Field Installed

O = Configure To Order (Factory Installed)

X = Field Installed

SPECIFICATIONS		7.5 TON			
General Data	Nominal Tonnage	7.5 Ton	7.5 Ton	7.5 Ton	7.5 Ton
	Model Number	KGA092S4B	KGA092S4M	KGA092H4B	KGA092H4M
	Efficiency Type	Standard	Standard	High	High
	Blower Type	Constant Air Volume (CAV)	Single Zone VAV Supply Fan	Constant Air Volume (CAV)	Single Zone VAV Supply Fan
Cooling Performance	Gross Cooling Capacity - Btuh	88,200	88,200	93,000	93,000
	¹ Net Cooling Capacity - Btuh	86,000	86,000	90,000	90,000
	AHRI Rated Air Flow - cfm	3000	3000	3000	2800
	Total Unit Power - kW	7.8	7.8	7.2	7.2
	¹ EER (Btuh/Watt)	11.0	11.0	12.5	12.5
	¹ IEER (Btuh/Watt)	11.8	13.0	13.0	14.0
	Refrigerant Type	R-410A	R-410A	R-410A	R-410A
	Refrigerant Charge Furnished	Circuit 1 4 lbs. 3 oz.	Circuit 1 4 lbs. 3 oz.	Circuit 1 7 lbs. 8 oz.	Circuit 1 7 lbs. 8 oz.
	Circuit 2 3 lbs. 6 oz.	Circuit 2 3 lbs. 6 oz.	Circuit 2 7 lbs. 8 oz.	Circuit 2 7 lbs. 8 oz.	
Gas Heating Options Available - See page 17	Standard (2 stage), Medium (2 Stage), High (2 Stage)				
Compressor Type (number)	Scroll (2)	Scroll (2)	Scroll (2)	Scroll (2)	
Outdoor Coils	Net face area (total) - sq. ft.	20.9	20.9	28.0	28.0
	Number of rows	1	1	1	1
	Fins per inch	23	23	20	20
Outdoor Coil Fans	Motor - (No.) hp	(2) 1/3	(2) 1/3	(2) 1/3	(2) 1/3
	Motor rpm	1075	1075	1075	1075
	Total Motor watts	740	740	800	800
	Diameter - (No.) in.	(2) 24	(2) 24	(2) 24	(2) 24
	Number of blades	3	3	3	3
	Total Air volume - cfm	8800	8800	8800	8800
Indoor Coils	Net face area (total) - sq. ft.	12.78	12.78	12.78	12.78
	Tube diameter - in.	3/8	3/8	3/8	3/8
	Number of rows	2	2	4	4
	Fins per inch	14	14	14	14
	Drain connection - Number and size	(2) 1 in. NPT coupling			
	Expansion device type	Refrigerant Metering Orifice (RFC)	Balance port TXV, removable head		
² Indoor Blower and Drive Selection	Nominal motor output	2 hp, 3 hp, 5 hp			
	Maximum usable motor output (US Only)	2.3 hp, 3.45 hp, 5.75 hp			
	Motor - Drive kit number	2 hp Kit 1 590-890 rpm Kit 2 800-1105 rpm Kit 3 795-1195 rpm 3 hp Kit 4 730-970 rpm Kit 5 940-1200 rpm Kit 6 1015-1300 rpm 5 hp Kit 10 900-1135 rpm Kit 11 1040-1315 rpm Kit 12 1125-1425 rpm			
	Blower wheel nominal diameter x width - in.	(1) 15 X 15	(1) 15 X 15	(1) 15 X 15	(1) 15 X 15
Filters	Type of filter	Disposable			
	Number and size - in.	(4) 20 x 25 x 2			
Electrical characteristics	208/230V, 460V or 575V - 60 hertz - 3 phase				

NOTE - Net capacity includes evaporator blower motor heat deduction. Gross capacity does not include evaporator blower motor heat deduction.

¹ AHRI Certified to AHRI Standard 340/360; 95°F outdoor air temperature and 80°F db/67°F wb entering evaporator air; minimum external duct static pressure.

² Using total air volume and system static pressure requirements determine from blower performance tables rpm and motor output required. Maximum usable output of motors furnished are shown. In Canada, nominal motor output is also maximum usable motor output. If motors of comparable output are used, be sure to keep within the service factor limitations outlined on the motor nameplate.

NOTE – Units equipped with Single Zone VAV Supply Fan option are limited to a motor service factor of 1.0.

SPECIFICATIONS		8.5 TON			
General Data	Nominal Tonnage	8.5 Ton	8.5 Ton	8.5 Ton	8.5 Ton
	Model Number	KGA102S4B	KGA102S4M	KGA102H4B	KGA102H4M
	Efficiency Type	Standard	Standard	High	High
	Blower Type	Constant Air Volume (CAV)	Single Zone VAV Supply Fan	Constant Air Volume (CAV)	Single Zone VAV Supply Fan
Cooling Performance	Gross Cooling Capacity - Btuh	99,600	99,600	103,800	103,800
	¹ Net Cooling Capacity - Btuh	97,000	97,000	100,000	100,000
	AHRI Rated Air Flow - cfm	3400	3400	3400	3400
	Total Unit Power - kW	8.8	8.8	8.2	8.2
	¹ EER (Btuh/Watt)	11.0	11.0	12.2	12.2
	¹ IEER (Btuh/Watt)	11.8	13.0	12.9	14.0
	Refrigerant Type	R-410A	R-410A	R-410A	R-410A
	Refrigerant Charge Furnished	Circuit 1 3 lbs. 12 oz.	Circuit 1 3 lbs. 12 oz.	Circuit 1 7 lbs. 8 oz.	Circuit 1 7 lbs. 8 oz.
	Circuit 2 3 lbs. 12 oz.	Circuit 2 3 lbs. 12 oz.	Circuit 2 7 lbs. 8 oz.	Circuit 2 7 lbs. 8 oz.	
Gas Heating Options Available - See page 17		Standard (2 stage), Medium (2 Stage), High (2 Stage)			
Compressor Type (number)		Scroll (2)	Scroll (2)	Scroll (2)	Scroll (2)
Outdoor Coils	Net face area (total) - sq. ft.	20.9	20.9	28.0	28.0
	Number of rows	1	1	1	1
	Fins per inch	23	23	20	20
Outdoor Coil Fans	Motor - (No.) hp	(2) 1/3	(2) 1/3	(2) 1/3	(2) 1/3
	Motor rpm	1075	1075	1075	1075
	Total Motor watts	740	740	800	800
	Diameter - (No.) in.	(2) 24	(2) 24	(2) 24	(2) 24
	Number of blades	3	3	3	3
	Total Air volume - cfm	8800	8800	8800	8800
Indoor Coils	Net face area (total) - sq. ft.	12.78	12.78	12.78	12.78
	Tube diameter - in.	3/8	3/8	3/8	3/8
	Number of rows	2	2	4	4
	Fins per inch	14	14	14	14
Drain connection - Number and size		(2) 1 in. NPT coupling			
Expansion device type		Refrigerant Metering Orifice (RFC)		Balance port TXV, removable head	
² Indoor Blower and Drive Selection	Nominal motor output	2 hp, 3 hp, 5 hp			
	Maximum usable motor output (US Only)	2.3 hp, 3.45 hp, 5.75 hp			
	Motor - Drive kit number	2 hp Kit 1 590-890 rpm Kit 2 800-1105 rpm Kit 3 795-1195 rpm 3 hp Kit 4 730-970 rpm Kit 5 940-1200 rpm Kit 6 1015-1300 rpm 5 hp Kit 10 900-1135 rpm Kit 11 1040-1315 rpm Kit 12 1125-1425 rpm			
Blower wheel nominal diameter x width - in.		(1) 15 X 15	(1) 15 X 15	(1) 15 X 15	(1) 15 X 15
Filters	Type of filter	Disposable			
	Number and size - in.	(4) 20 x 25 x 2			
Electrical characteristics		208/230V, 460V or 575V - 60 hertz - 3 phase			

NOTE - Net capacity includes evaporator blower motor heat deduction. Gross capacity does not include evaporator blower motor heat deduction.

¹ AHRI Certified to AHRI Standard 340/360; 95°F outdoor air temperature and 80°F db/67°F wb entering evaporator air; minimum external duct static pressure.

² Using total air volume and system static pressure requirements determine from blower performance tables rpm and motor output required. Maximum usable output of motors furnished are shown. In Canada, nominal motor output is also maximum usable motor output. If motors of comparable output are used, be sure to keep within the service factor limitations outlined on the motor nameplate.

NOTE – Units equipped with Single Zone VAV Supply Fan option are limited to a motor service factor of 1.0.

SPECIFICATIONS		10 TON			
General Data	Nominal Tonnage	10 Ton	10 Ton	10 Ton	10 Ton
	Model Number	KGA120S4B	KGA120S4M	KGA120H4B	KGA120H4M
	Efficiency Type	Standard	Standard	High	High
	Blower Type	Constant Air Volume (CAV)	Single Zone VAV Supply Fan	Constant Air Volume (CAV)	Single Zone VAV Supply Fan
Cooling Performance	Gross Cooling Capacity - Btuh	118,400	118,400	122,000	122,000
	¹ Net Cooling Capacity - Btuh	115,000	115,000	118,000	118,000
	AHRI Rated Air Flow - cfm	3800	3800	3600	3300
	Total Unit Power - kW	10.5	10.5	9.8	9.8
	¹ EER (Btuh/Watt)	11.0	11.0	12	12
	¹ IEER (Btuh/Watt)	11.8	13.0	13	13.8
	Refrigerant Type	R-410A	R-410A	R-410A	R-410A
	Refrigerant Charge Furnished	Circuit 1 4 lbs. 12 oz.	Circuit 1 4 lbs. 12 oz.	Circuit 1 7 lbs. 4 oz.	Circuit 1 7 lbs. 4 oz.
		Circuit 2 4 lbs. 10 oz.	Circuit 2 4 lbs. 10 oz.	Circuit 2 7 lbs. 8 oz.	Circuit 2 7 lbs. 8 oz.
	Gas Heating Options Available - See page 17		Standard (2 stage), Medium (2 Stage), High (2 Stage)		
Compressor Type (number)		Scroll (2)	Scroll (2)	Scroll (2)	Scroll (2)
Outdoor Coils	Net face area (total) - sq. ft.	28.0	28.0	28.0	28.0
	Number of rows	1	1	1	1
	Fins per inch	23	23	20	20
Outdoor Coil Fans	Motor - (No.) hp	(2) 1/3	(2) 1/3	(2) 1/3	(2) 1/3
	Motor rpm	1075	1075	1075	1075
	Total Motor watts	690	690	800	800
	Diameter - (No.) in.	(2) 24	(2) 24	(2) 24	(2) 24
	Number of blades	3	3	3	3
	Total Air volume - cfm	9300	9300	8800	8800
Indoor Coils	Net face area (total) - sq. ft.	12.78	12.78	13.54	13.54
	Tube diameter - in.	3/8	3/8	3/8	3/8
	Number of rows	3	3	4	4
	Fins per inch	14	14	14	14
Drain connection - Number and size		(2) 1 in. NPT coupling			
Expansion device type		Refrigerant Metering Orifice (RFC)		Balance port TXV, removable head	
² Indoor Blower and Drive Selection	Nominal motor output	2 hp, 3 hp, 5 hp			
	Maximum usable motor output (US Only)	2.3 hp, 3.45 hp, 5.75 hp			
	Motor - Drive kit number	2 hp Kit 1 590-890 rpm Kit 2 800-1105 rpm Kit 3 795-1195 rpm 3 hp Kit 4 730-970 rpm Kit 5 940-1200 rpm Kit 6 1015-1300 rpm 5 hp Kit 10 900-1135 rpm Kit 11 1040-1315 rpm Kit 12 1125-1425 rpm			
Blower wheel nominal diameter x width - in.		(1) 15 X 15	(1) 15 X 15	(1) 15 X 15	(1) 15 X 15
Filters	Type of filter	Disposable			
	Number and size - in.	(4) 20 x 25 x 2			
Electrical characteristics		208/230V, 460V or 575V - 60 hertz - 3 phase			

NOTE - Net capacity includes evaporator blower motor heat deduction. Gross capacity does not include evaporator blower motor heat deduction.

¹ AHRI Certified to AHRI Standard 340/360; 95°F outdoor air temperature and 80°F db/67°F wb entering evaporator air; minimum external duct static pressure.

² Using total air volume and system static pressure requirements determine from blower performance tables rpm and motor output required. Maximum usable output of motors furnished are shown. In Canada, nominal motor output is also maximum usable motor output. If motors of comparable output are used, be sure to keep within the service factor limitations outlined on the motor nameplate.

NOTE – Units equipped with Single Zone VAV Supply Fan option are limited to a motor service factor of 1.0.

SPECIFICATIONS
12.5 TON

General Data		Nominal Tonnage	12.5 Ton	12.5 Ton
		Model Number	KGA150S4B	KGA150S4M
		Efficiency Type	Standard	Standard
		Blower Type	Constant Air Volume (CAV)	Single Zone VAV Supply Fan
Cooling Performance	Gross Cooling Capacity - Btuh		142,600	142,600
	¹ Net Cooling Capacity - Btuh		138,000	138,000
	AHRI Rated Air Flow - cfm		4300	4300
	Total Unit Power - kW		12.5	12.5
	¹ EER (Btuh/Watt)		11.0	11.0
	¹ IEER (Btuh/Watt)		11.4	12.0
	Refrigerant Type		R-410A	R-410A
	Refrigerant Charge Furnished	Circuit 1	7 lbs. 4 oz.	7 lbs. 4 oz.
		Circuit 2	6 lbs. 12 oz.	6 lbs. 12 oz.
Gas Heating Options Available - See page 17			Standard (2 stage), Medium (2 Stage), High (2 Stage)	
Compressor Type (number)			Scroll (2)	Scroll (2)
Outdoor Coils	Net face area (total) - sq. ft.		28.0	28.0
	Number of rows		1	1
	Fins per inch		20	20
Outdoor Coil Fans	Motor - (No.) hp		(2) 1/2	(2) 1/2
	Motor rpm		1075	1075
	Total Motor watts		1050	1050
	Diameter - (No.) in.		(2) 24	(2) 24
	Number of blades		3	3
	Total Air volume - cfm		9700	9700
Indoor Coils	Net face area (total) - sq. ft.		13.54	13.54
	Tube diameter - in.		3/8	3/8
	Number of rows		4	4
	Fins per inch		14	14
	Drain connection - Number and size		(2) 1 in. NPT coupling	
	Expansion device type		Refrigerant Metering Orifice (RFC)	
² Indoor Blower and Drive Selection	Nominal motor output		2 hp, 3 hp, 5 hp	
	Maximum usable motor output (US Only)		2.3 hp, 3.45 hp, 5.75 hp	
	Motor - Drive kit number		2 hp Kit 1 590-890 rpm Kit 2 800-1105 rpm Kit 3 795-1195 rpm 3 hp Kit 4 730-970 rpm Kit 5 940-1200 rpm Kit 6 1015-1300 rpm 5 hp Kit 10 900-1135 rpm Kit 11 1040-1315 rpm Kit 12 1125-1425 rpm	
	Blower wheel nominal diameter x width - in.		(1) 15 X 15	(1) 15 X 15
Filters	Type of filter		Disposable	
	Number and size - in.		(4) 20 x 25 x 2	
Electrical characteristics			208/230V, 460V or 575V - 60 hertz - 3 phase	

NOTE - Net capacity includes evaporator blower motor heat deduction. Gross capacity does not include evaporator blower motor heat deduction.

¹ AHRI Certified to AHRI Standard 340/360; 95°F outdoor air temperature and 80°F db/67°F wb entering evaporator air; minimum external duct static pressure.

² Using total air volume and system static pressure requirements determine from blower performance tables rpm and motor output required. Maximum usable output of motors furnished are shown. In Canada, nominal motor output is also maximum usable motor output. If motors of comparable output are used, be sure to keep within the service factor limitations outlined on the motor nameplate.

NOTE – Units equipped with Single Zone VAV Supply Fan option are limited to a motor service factor of 1.0.

SPECIFICATIONS - GAS HEAT

		Heat Input Type	Standard	Medium	High
		Number of Gas Heat Stages	2	2	2
Gas Heating Performance	Input - Btuh	First Stage	84,500	117,000	156,000
		Second Stage	130,000	180,000	240,000
	Output - Btuh	Second Stage	104,000	144,000	192,000
	Temperature Rise Range - °F		15-45	30-60	40-70
	Thermal Efficiency		80%	80%	80%
	Gas Supply Connections		3/4 in NPT	3/4 in NPT	3/4 in NPT
Recommended Gas Supply Pressure - in. w.g.	Natural		7	7	7
	LPG/Propane		11	11	11

HIGH ALTITUDE DERATE

Units may be installed at altitudes up to 2000 feet above sea level without any modification.

At altitudes above 2000 feet, units must be derated to match gas manifold pressures shown in table below.

At altitudes above 4500 feet unit must be derated 2% for each 1000 feet above sea level.

NOTE – This is the only permissible derate for these units.

Gas Heat Type	Altitude	Gas Manifold Pressure		Input Rate Natural Gas or LPG/Propane	
		Natural Gas	LPG/Propane Gas	First Stage	Second Stage
	ft.	In. w.g.	In. w.g.	Btuh	Btuh
Standard	2001-4500	3.4	9.6	84,500	124,000
Medium	2001-4500	3.4	9.6	117,000	172,000
High	2001-4500	3.4	9.6	156,000	230,000

RATINGS

NOTE – For Temperatures and Capacities not shown in tables, see bulletin – Cooling Unit Rating Table Correction Factor Data in Miscellaneous Engineering Data section.

7.5 TON STANDARD EFFICIENCY KGA092S4B (1ST STAGE) - CONSTANT AIR VOLUME

Entering Wet Bulb Temperature	Total Air Volume	Outdoor Air Temperature Entering Outdoor Coil																			
		65°F					75°F					85°F					95°F				
		Total Cool Cap.	Comp. Motor Input	Sensible To Total Ratio (S/T)			Total Cool Cap.	Comp. Motor Input	Sensible To Total Ratio (S/T)			Total Cool Cap.	Comp. Motor Input	Sensible To Total Ratio (S/T)			Total Cool Cap.	Comp. Motor Input	Sensible To Total Ratio (S/T)		
				Dry Bulb					Dry Bulb					Dry Bulb					Dry Bulb		
cfm	kBtuh	kW	75°F	80°F	85°F	kBtuh	kW	75°F	80°F	85°F	kBtuh	kW	75°F	80°F	85°F	kBtuh	kW	75°F	80°F	85°F	
63°F	2400	63.6	2.73	0.66	0.77	0.90	60.9	3.06	0.66	0.78	0.91	57.8	3.43	0.67	0.80	0.93	54.5	3.86	0.68	0.82	0.96
	3000	67.1	2.76	0.69	0.83	0.96	64.3	3.08	0.70	0.84	0.98	61.1	3.45	0.71	0.86	0.99	57.6	3.88	0.72	0.88	1.00
	3600	70.2	2.78	0.72	0.88	1.00	67.1	3.10	0.73	0.89	1.00	63.7	3.47	0.74	0.91	1.00	60.0	3.90	0.76	0.94	1.00
67°F	2400	66.8	2.76	0.53	0.64	0.74	64.0	3.08	0.54	0.64	0.75	60.9	3.45	0.54	0.65	0.76	57.4	3.88	0.54	0.66	0.78
	3000	70.7	2.79	0.55	0.67	0.79	67.5	3.10	0.56	0.67	0.81	64.1	3.47	0.56	0.68	0.82	60.5	3.91	0.56	0.70	0.85
	3600	73.5	2.80	0.57	0.70	0.84	70.2	3.12	0.57	0.71	0.86	66.6	3.49	0.58	0.72	0.88	62.6	3.92	0.58	0.74	0.90
71°F	2400	69.7	2.78	0.42	0.52	0.61	66.8	3.10	0.42	0.52	0.62	63.6	3.47	0.41	0.52	0.63	60.1	3.90	0.40	0.53	0.64
	3000	73.9	2.81	0.43	0.54	0.65	70.6	3.12	0.43	0.54	0.65	67.1	3.50	0.42	0.55	0.66	63.3	3.93	0.41	0.55	0.68
	3600	77.0	2.83	0.44	0.56	0.68	73.5	3.14	0.44	0.56	0.69	69.6	3.51	0.41	0.57	0.70	65.6	3.95	0.42	0.57	0.72

7.5 TON STANDARD EFFICIENCY KGA092S4B (2ND STAGE) - CONSTANT AIR VOLUME

Entering Wet Bulb Temperature	Total Air Volume	Outdoor Air Temperature Entering Outdoor Coil																			
		85°F					95°F					105°F					115°F				
		Total Cool Cap.	Comp. Motor Input	Sensible To Total Ratio (S/T)			Total Cool Cap.	Comp. Motor Input	Sensible To Total Ratio (S/T)			Total Cool Cap.	Comp. Motor Input	Sensible To Total Ratio (S/T)			Total Cool Cap.	Comp. Motor Input	Sensible To Total Ratio (S/T)		
				Dry Bulb					Dry Bulb					Dry Bulb					Dry Bulb		
cfm	kBtuh	kW	75°F	80°F	85°F	kBtuh	kW	75°F	80°F	85°F	kBtuh	kW	75°F	80°F	85°F	kBtuh	kW	75°F	80°F	85°F	
63°F	2400	86.0	5.76	0.68	0.82	0.96	80.6	6.50	0.69	0.84	0.98	74.8	7.36	0.71	0.87	1.00	68.6	8.33	0.73	0.90	1.00
	3000	90.8	5.80	0.73	0.89	1.00	85.0	6.54	0.74	0.92	1.00	78.8	7.40	0.76	0.95	1.00	72.2	8.38	0.79	0.98	1.00
	3600	94.4	5.82	0.77	0.95	1.00	88.3	6.57	0.79	0.98	1.00	82.0	7.43	0.82	0.99	1.00	75.5	8.42	0.85	1.00	1.00
67°F	2400	90.7	5.79	0.54	0.66	0.78	85.2	6.54	0.54	0.67	0.80	79.3	7.40	0.55	0.69	0.83	72.7	8.38	0.56	0.70	0.86
	3000	96.0	5.83	0.57	0.70	0.85	89.9	6.58	0.57	0.72	0.88	83.5	7.45	0.58	0.74	0.91	76.7	8.43	0.59	0.77	0.95
	3600	99.7	5.85	0.59	0.75	0.92	93.4	6.61	0.60	0.77	0.95	86.6	7.48	0.61	0.79	0.98	79.3	8.47	0.63	0.83	1.00
71°F	2400	95.0	5.82	0.41	0.53	0.64	89.5	6.58	0.41	0.53	0.65	83.3	7.44	0.4	0.54	0.66	76.7	8.43	0.40	0.55	0.68
	3000	100.7	5.86	0.43	0.56	0.68	94.5	6.62	0.42	0.56	0.70	87.9	7.49	0.41	0.57	0.72	80.8	8.48	0.41	0.58	0.74
	3600	104.7	5.89	0.43	0.58	0.72	98.1	6.65	0.43	0.59	0.74	91.2	7.52	0.43	0.60	0.77	83.8	8.52	0.43	0.62	0.80

7.5 TON HIGH EFFICIENCY KGA092H4B (1ST STAGE) - CONSTANT AIR VOLUME

Entering Wet Bulb Temperature	Total Air Volume	Outdoor Air Temperature Entering Outdoor Coil																			
		65°F					75°F					85°F					95°F				
		Total Cool Cap.	Comp. Motor Input	Sensible To Total Ratio (S/T)			Total Cool Cap.	Comp. Motor Input	Sensible To Total Ratio (S/T)			Total Cool Cap.	Comp. Motor Input	Sensible To Total Ratio (S/T)			Total Cool Cap.	Comp. Motor Input	Sensible To Total Ratio (S/T)		
				Dry Bulb					Dry Bulb					Dry Bulb					Dry Bulb		
cfm	kBtuh	kW	75°F	80°F	85°F	kBtuh	kW	75°F	80°F	85°F	kBtuh	kW	75°F	80°F	85°F	kBtuh	kW	75°F	80°F	85°F	
63°F	2400	48.2	1.95	0.67	0.80	0.95	46.2	2.21	0.67	0.81	0.97	43.9	2.49	0.68	0.83	0.99	41.7	2.81	0.69	0.85	1.00
	3000	50.8	1.96	0.71	0.88	1.00	48.6	2.21	0.72	0.90	1.00	46.2	2.49	0.74	0.92	1.00	43.7	2.81	0.76	0.96	1.00
	3600	52.8	1.96	0.76	0.96	1.00	50.4	2.22	0.78	0.98	1.00	48.0	2.50	0.80	1.00	1.00	45.6	2.81	0.82	1.00	1.00
67°F	2400	51.1	1.96	0.53	0.65	0.76	48.9	2.21	0.53	0.65	0.78	46.6	2.49	0.54	0.66	0.79	44.1	2.81	0.54	0.67	0.81
	3000	53.8	1.97	0.55	0.69	0.84	51.4	2.22	0.56	0.70	0.86	48.9	2.50	0.57	0.71	0.88	46.4	2.82	0.58	0.73	0.92
	3600	55.7	1.97	0.59	0.74	0.91	53.3	2.22	0.60	0.76	0.95	50.6	2.50	0.61	0.78	0.97	47.7	2.82	0.61	0.80	1.00
71°F	2400	54.2	1.97	0.41	0.52	0.62	51.9	2.22	0.41	0.52	0.63	49.5	2.50	0.41	0.52	0.64	47.1	2.82	0.41	0.53	0.65
	3000	56.7	1.98	0.41	0.54	0.67	54.3	2.23	0.42	0.55	0.68	51.7	2.51	0.42	0.56	0.69	48.9	2.82	0.42	0.57	0.71
	3600	58.6	1.98	0.43	0.57	0.71	56.1	2.23	0.44	0.58	0.73	53.4	2.51	0.43	0.60	0.75	50.6	2.83	0.43	0.61	0.78

7.5 TON HIGH EFFICIENCY KGA092H4B (2ND STAGE) - CONSTANT AIR VOLUME

Entering Wet Bulb Temperature	Total Air Volume	Outdoor Air Temperature Entering Outdoor Coil																			
		85°F					95°F					105°F					115°F				
		Total Cool Cap.	Comp. Motor Input	Sensible To Total Ratio (S/T)			Total Cool Cap.	Comp. Motor Input	Sensible To Total Ratio (S/T)			Total Cool Cap.	Comp. Motor Input	Sensible To Total Ratio (S/T)			Total Cool Cap.	Comp. Motor Input	Sensible To Total Ratio (S/T)		
				Dry Bulb					Dry Bulb					Dry Bulb					Dry Bulb		
cfm	kBtuh	kW	75°F	80°F	85°F	kBtuh	kW	75°F	80°F	85°F	kBtuh	kW	75°F	80°F	85°F	kBtuh	kW	75°F	80°F	85°F	
63°F	2400	87.9	4.98	0.68	0.83	0.99	83.4	5.62	0.69	0.85	1.00	78.4	6.36	0.71	0.88	1.00	73.1	7.23	0.73	0.92	1.00
	3000	92.4	4.99	0.74	0.92	1.00	87.6	5.63	0.76	0.96	1.00	82.3	6.37	0.78	0.98	1.00	76.8	7.22	0.80	1.00	1.00
	3600	96.0	5.00	0.80	1.00	1.00	91.2	5.64	0.82	1.00	1.00	86.4	6.37	0.85	1.00	1.00	81.2	7.22	0.88	1.00	1.00
67°F	2400	93.3	4.99	0.54	0.66	0.79	88.4	5.63	0.54	0.67	0.81	83.3	6.37	0.55	0.68	0.84	78.0	7.23	0.56	0.71	0.88
	3000	97.9	5.00	0.57	0.71	0.88	93.0	5.64	0.58	0.73	0.91	87.2	6.37	0.59	0.75	0.95	81.1	7.22	0.59	0.78	0.99
	3600	101.4	5.01	0.61	0.77	0.97	95.6	5.64	0.61	0.79	1.00	90.0	6.38	0.62	0.82	1.00	83.6	7.22	0.64	0.86	1.00
71°F	2400	99.1	5.00	0.41	0.52	0.64	94.0	5.64	0.41	0.53	0.65	88.6	6.37	0.4	0.54	0.66	82.7	7.22	0.41	0.55	0.68
	3000	103.3	5.01	0.42	0.56	0.69	98.0	5.65	0.42	0.57	0.71	92.2	6.38	0.42	0.58	0.73	86.0	7.23	0.43	0.59	0.75
	3600	106.9	5.02	0.44	0.60	0.75	101.2	5.66	0.43	0.60	0.77	95.0	6.38	0.44	0.61	0.8	88.3	7.22	0.44	0.63	0.84

RATINGS

NOTE – For Temperatures and Capacities not shown in tables, see bulletin – Cooling Unit Rating Table Correction Factor Data in Miscellaneous Engineering Data section.

8.5 TON STANDARD EFFICIENCY KGA102S4B (1ST STAGE) - CONSTANT AIR VOLUME

Entering Wet Bulb Temperature	Total Air Volume	Outdoor Air Temperature Entering Outdoor Coil																			
		65°F					75°F					85°F					95°F				
		Total Cool Cap.	Comp. Motor Input	Sensible To Total Ratio (S/T)			Total Cool Cap.	Comp. Motor Input	Sensible To Total Ratio (S/T)			Total Cool Cap.	Comp. Motor Input	Sensible To Total Ratio (S/T)			Total Cool Cap.	Comp. Motor Input	Sensible To Total Ratio (S/T)		
				Dry Bulb					Dry Bulb					Dry Bulb					Dry Bulb		
				75°F	80°F	85°F			75°F	80°F	85°F			75°F	80°F	85°F			75°F	80°F	85°F
cfm	kBtuh	kW				kBtuh	kW				kBtuh	kW				kBtuh	kW				
63°F	2720	57.3	2.49	0.63	0.76	0.91	53.8	2.78	0.63	0.77	0.93	50.0	3.10	0.63	0.79	0.96	46.1	3.49	0.63	0.81	0.99
	3400	61.1	2.51	0.67	0.83	0.99	57.4	2.79	0.67	0.85	1.00	53.3	3.11	0.68	0.87	1.00	49.0	3.49	0.69	0.90	1.00
	4080	63.9	2.51	0.71	0.90	1.00	59.9	2.79	0.72	0.92	1.00	55.7	3.12	0.73	0.95	1.00	51.1	3.50	0.75	0.98	1.00
67°F	2720	60.9	2.50	0.50	0.61	0.73	57.2	2.79	0.50	0.61	0.73	53.4	3.11	0.49	0.61	0.75	49.3	3.49	0.49	0.62	0.76
	3400	64.9	2.50	0.53	0.65	0.79	61.0	2.79	0.52	0.65	0.81	56.8	3.12	0.52	0.66	0.83	52.4	3.50	0.52	0.67	0.86
	4080	67.8	2.52	0.55	0.69	0.86	63.7	2.81	0.55	0.69	0.88	59.4	3.13	0.55	0.71	0.91	54.7	3.51	0.55	0.73	0.94
71°F	2720	64.2	2.51	0.39	0.49	0.59	60.5	2.80	0.38	0.49	0.59	56.5	3.12	0.37	0.48	0.59	52.4	3.51	0.35	0.48	0.60
	3400	68.4	2.52	0.40	0.52	0.63	64.4	2.80	0.39	0.52	0.63	60.1	3.13	0.38	0.51	0.64	55.6	3.52	0.37	0.51	0.65
	4080	71.4	2.53	0.41	0.54	0.66	67.3	2.82	0.41	0.54	0.67	62.8	3.14	0.40	0.54	0.69	58.0	3.52	0.39	0.54	0.70

8.5 TON STANDARD EFFICIENCY KGA102S4B (2ND STAGE) - CONSTANT AIR VOLUME

Entering Wet Bulb Temperature	Total Air Volume	Outdoor Air Temperature Entering Outdoor Coil																			
		85°F					95°F					105°F					115°F				
		Total Cool Cap.	Comp. Motor Input	Sensible To Total Ratio (S/T)			Total Cool Cap.	Comp. Motor Input	Sensible To Total Ratio (S/T)			Total Cool Cap.	Comp. Motor Input	Sensible To Total Ratio (S/T)			Total Cool Cap.	Comp. Motor Input	Sensible To Total Ratio (S/T)		
				Dry Bulb					Dry Bulb					Dry Bulb					Dry Bulb		
				75°F	80°F	85°F			75°F	80°F	85°F			75°F	80°F	85°F			75°F	80°F	85°F
cfm	kBtuh	kW				kBtuh	kW				kBtuh	kW				kBtuh	kW				
63°F	2720	95.0	6.52	0.67	0.82	0.96	87.4	7.34	0.67	0.83	0.99	79.3	8.28	0.68	0.85	1.00	70.8	9.42	0.69	0.88	1.00
	3400	101.3	6.54	0.72	0.89	1.00	93.1	7.35	0.73	0.91	1.00	84.6	8.30	0.74	0.94	1.00	75.4	9.43	0.76	0.98	1.00
	4080	105.8	6.55	0.77	0.96	1.00	97.1	7.37	0.78	0.98	1.00	88.4	8.31	0.80	1.00	1.00	79.8	9.44	0.83	1.00	1.00
67°F	2720	101.4	6.54	0.52	0.65	0.78	93.5	7.34	0.52	0.66	0.80	85.3	8.30	0.50	0.66	0.82	76.5	9.43	0.50	0.67	0.84
	3400	108.0	6.56	0.55	0.70	0.85	99.6	7.37	0.55	0.71	0.87	90.8	8.31	0.55	0.72	0.90	81.5	9.43	0.54	0.74	0.94
	4080	112.7	6.57	0.58	0.75	0.92	103.9	7.37	0.58	0.76	0.95	94.8	8.33	0.58	0.78	0.98	85.1	9.46	0.59	0.81	1.00
71°F	2720	107.3	6.56	0.38	0.52	0.63	99.5	7.37	0.37	0.51	0.64	91.0	8.31	0.35	0.50	0.64	82.1	9.45	0.33	0.49	0.65
	3400	114.3	6.58	0.40	0.54	0.68	105.7	7.39	0.39	0.54	0.69	96.6	8.34	0.37	0.54	0.70	87.2	9.46	0.35	0.54	0.72
	4080	119.3	6.60	0.41	0.58	0.73	110.2	7.40	0.40	0.58	0.74	100.8	8.36	0.39	0.58	0.76	90.9	9.49	0.38	0.59	0.78

8.5 TON HIGH EFFICIENCY KGA102H4B (1ST STAGE) - CONSTANT AIR VOLUME

Entering Wet Bulb Temperature	Total Air Volume	Outdoor Air Temperature Entering Outdoor Coil																			
		65°F					75°F					85°F					95°F				
		Total Cool Cap.	Comp. Motor Input	Sensible To Total Ratio (S/T)			Total Cool Cap.	Comp. Motor Input	Sensible To Total Ratio (S/T)			Total Cool Cap.	Comp. Motor Input	Sensible To Total Ratio (S/T)			Total Cool Cap.	Comp. Motor Input	Sensible To Total Ratio (S/T)		
				Dry Bulb					Dry Bulb					Dry Bulb					Dry Bulb		
				75°F	80°F	85°F			75°F	80°F	85°F			75°F	80°F	85°F			75°F	80°F	85°F
cfm	kBtuh	kW				kBtuh	kW				kBtuh	kW				kBtuh	kW				
63°F	2720	53.6	2.17	0.61	0.76	0.95	50.7	2.45	0.62	0.78	0.98	47.7	2.77	0.62	0.8	1.00	44.6	3.13	0.63	0.83	1.00
	3400	56.5	2.18	0.66	0.87	1.00	53.5	2.46	0.66	0.89	1.00	50.3	2.78	0.68	0.93	1.00	47.1	3.13	0.70	0.97	1.00
	4080	58.7	2.18	0.72	0.97	1.00	55.6	2.47	0.74	1.00	1.00	52.4	2.78	0.76	1.00	1.00	49.4	3.14	0.78	1.00	1.00
67°F	2720	57.0	2.18	0.48	0.59	0.71	54.1	2.46	0.49	0.60	0.73	51.0	2.78	0.48	0.61	0.75	47.7	3.14	0.48	0.61	0.78
	3400	60.0	2.19	0.51	0.64	0.82	56.8	2.47	0.51	0.64	0.84	53.6	2.78	0.52	0.66	0.88	50.1	3.14	0.52	0.67	0.92
	4080	62.2	2.19	0.54	0.69	0.93	58.9	2.48	0.55	0.71	0.96	55.5	2.79	0.55	0.73	0.99	51.8	3.14	0.55	0.76	1.00
71°F	2720	60.4	2.19	0.37	0.47	0.57	57.5	2.47	0.37	0.48	0.58	54.2	2.78	0.36	0.47	0.59	50.8	3.14	0.35	0.47	0.59
	3400	63.5	2.20	0.38	0.50	0.62	60.2	2.48	0.38	0.51	0.63	56.8	2.79	0.37	0.51	0.64	53.3	3.15	0.37	0.52	0.65
	4080	65.6	2.20	0.39	0.53	0.67	62.3	2.49	0.40	0.54	0.68	58.9	2.80	0.39	0.54	0.70	55.0	3.15	0.39	0.55	0.73

8.5 TON HIGH EFFICIENCY KGA102H4B (2ND STAGE) - CONSTANT AIR VOLUME

Entering Wet Bulb Temperature	Total Air Volume	Outdoor Air Temperature Entering Outdoor Coil																			
		85°F					95°F					105°F					115°F				
		Total Cool Cap.	Comp. Motor Input	Sensible To Total Ratio (S/T)			Total Cool Cap.	Comp. Motor Input	Sensible To Total Ratio (S/T)			Total Cool Cap.	Comp. Motor Input	Sensible To Total Ratio (S/T)			Total Cool Cap.	Comp. Motor Input	Sensible To Total Ratio (S/T)		
				Dry Bulb					Dry Bulb					Dry Bulb					Dry Bulb		
				75°F	80°F	85°F			75°F	80°F	85°F			75°F	80°F	85°F			75°F	80°F	85°F
cfm	kBtuh	kW				kBtuh	kW				kBtuh	kW				kBtuh	kW				
63°F	2720	98.9	5.54	0.70	0.85	1.00	92.5	6.27	0.71	0.87	1.00	85.7	7.10	0.71	0.90	1.00	78.6	8.09	0.73	0.94	1.00
	3400	104.2	5.56	0.76	0.95	1.00	97.5	6.27	0.77	0.98	1.00	90.4	7.11	0.79	1.00	1.00	83.6	8.08	0.82	1.00	1.00
	4080	108.6	5.56	0.82	1.00	1.00	102.3	6.28	0.84	1.00	1.00	95.9	7.12	0.87	1.00	1.00	88.9	8.08	0.91	1.00	1.00
67°F	2720	105.6	5.56	0.53	0.67	0.81	98.9	6.28	0.53	0.68	0.83	91.8	7.11	0.54	0.69	0.87	84.4	8.08	0.55	0.71	0.90
	3400	110.9	5.57	0.58	0.74	0.91	103.8	6.29	0.59	0.75	0.94	96.4	7.12	0.59	0.77	0.97	88.5	8.08	0.59	0.79	1.00
	4080	114.8	5.58	0.61	0.80	0.99	107.2	6.30	0.62	0.82	1.00	99.6	7.12	0.63	0.85	1.00	91.5	8.08	0.63	0.88	1.00
71°F	2720	112.1	5.57	0.40	0.53	0.65	105.2	6.29	0.39	0.53	0.66	98.1	7.12	0.38	0.53	0.67	90.3	8.08	0.38	0.54	0.69
	3400	117.6	5.59	0.42	0.57	0.72	110.4	6.30	0.41	0.58	0.73	102.7	7.12	0.41	0.58	0.75	94.3	8.08	0.40	0.59	0.77
	4080	121.7	5.60	0.44	0.61	0.77	113.9	6.31	0.43	0.61	0.79	105.9	7.13	0.42	0.62	0.83	97.4	8.08	0.43	0.63	0.86

RATINGS

NOTE – For Temperatures and Capacities not shown in tables, see bulletin – Cooling Unit Rating Table Correction Factor Data in Miscellaneous Engineering Data section.

10 TON STANDARD EFFICIENCY KGA120S4B (1ST STAGE) - CONSTANT AIR VOLUME

Entering Wet Bulb Temperature	Total Air Volume	Outdoor Air Temperature Entering Outdoor Coil																			
		65°F					75°F					85°F					95°F				
		Total Cool Cap.	Comp. Motor Input	Sensible To Total Ratio (S/T)			Total Cool Cap.	Comp. Motor Input	Sensible To Total Ratio (S/T)			Total Cool Cap.	Comp. Motor Input	Sensible To Total Ratio (S/T)			Total Cool Cap.	Comp. Motor Input	Sensible To Total Ratio (S/T)		
				Dry Bulb					Dry Bulb					Dry Bulb					Dry Bulb		
cfm	kBtuh	kW	75°F	80°F	85°F	kBtuh	kW	75°F	80°F	85°F	kBtuh	kW	75°F	80°F	85°F	kBtuh	kW	75°F	80°F	85°F	
63°F	3200	62.2	2.85	0.66	0.80	0.94	58.1	3.21	0.66	0.81	0.96	53.6	3.62	0.66	0.82	0.98	49.0	4.09	0.66	0.84	1.00
	4000	66.2	2.86	0.71	0.87	1.00	61.8	3.23	0.71	0.88	1.00	57.2	3.65	0.71	0.90	1.00	52.4	4.11	0.73	0.93	1.00
	4800	69.2	2.89	0.75	0.94	1.00	64.7	3.24	0.76	0.96	1.00	59.9	3.66	0.78	0.98	1.00	54.9	4.14	0.79	1.00	1.00
67°F	3200	66.8	2.87	0.53	0.64	0.76	62.4	3.23	0.52	0.64	0.77	57.9	3.65	0.51	0.64	0.78	53.1	4.12	0.50	0.64	0.80
	4000	70.8	2.88	0.55	0.69	0.83	66.2	3.25	0.55	0.69	0.85	61.3	3.67	0.54	0.69	0.86	56.3	4.15	0.54	0.70	0.89
	4800	73.7	2.89	0.58	0.73	0.90	68.8	3.27	0.57	0.74	0.92	63.9	3.69	0.58	0.75	0.94	58.7	4.17	0.57	0.77	0.97
71°F	3200	71.3	2.89	0.41	0.52	0.62	66.9	3.26	0.39	0.51	0.62	62.1	3.68	0.37	0.50	0.62	57.1	4.16	0.36	0.49	0.63
	4000	75.4	2.90	0.42	0.55	0.67	70.7	3.28	0.40	0.54	0.67	65.7	3.70	0.39	0.54	0.68	60.3	4.18	0.38	0.53	0.68
	4800	78.4	2.92	0.43	0.58	0.71	73.4	3.29	0.42	0.57	0.72	68.2	3.72	0.41	0.57	0.73	62.8	4.20	0.40	0.57	0.75

10 TON STANDARD EFFICIENCY KGA120S4B (2ND STAGE) - CONSTANT AIR VOLUME

Entering Wet Bulb Temperature	Total Air Volume	Outdoor Air Temperature Entering Outdoor Coil																			
		85°F					95°F					105°F					115°F				
		Total Cool Cap.	Comp. Motor Input	Sensible To Total Ratio (S/T)			Total Cool Cap.	Comp. Motor Input	Sensible To Total Ratio (S/T)			Total Cool Cap.	Comp. Motor Input	Sensible To Total Ratio (S/T)			Total Cool Cap.	Comp. Motor Input	Sensible To Total Ratio (S/T)		
				Dry Bulb					Dry Bulb					Dry Bulb					Dry Bulb		
cfm	kBtuh	kW	75°F	80°F	85°F	kBtuh	kW	75°F	80°F	85°F	kBtuh	kW	75°F	80°F	85°F	kBtuh	kW	75°F	80°F	85°F	
63°F	3200	114.0	7.38	0.68	0.83	0.98	104.2	8.32	0.68	0.85	1.00	93.9	9.38	0.68	0.87	1.00	83.2	10.57	0.69	0.91	1.00
	4000	121.0	7.42	0.73	0.92	1.00	111.1	8.38	0.74	0.94	1.00	100.5	9.44	0.76	0.97	1.00	89.4	10.64	0.78	1.00	1.00
	4800	126.9	7.46	0.79	0.99	1.00	116.4	8.42	0.81	1.00	1.00	106.5	9.50	0.83	1.00	1.00	96.0	10.71	0.86	1.00	1.00
67°F	3200	123.1	7.43	0.52	0.66	0.79	113.0	8.39	0.51	0.66	0.81	102.5	9.46	0.50	0.67	0.83	91.5	10.66	0.49	0.67	0.87
	4000	130.6	7.48	0.55	0.71	0.88	120.0	8.44	0.55	0.72	0.90	108.8	9.52	0.55	0.74	0.93	97.0	10.73	0.55	0.76	0.98
	4800	136.0	7.51	0.59	0.77	0.95	124.9	8.48	0.59	0.78	0.98	113.3	9.56	0.59	0.81	1.00	101.2	10.77	0.60	0.84	1.00
71°F	3200	131.9	7.49	0.38	0.51	0.64	121.7	8.45	0.36	0.50	0.64	110.7	9.53	0.34	0.50	0.65	99.4	10.75	0.32	0.49	0.65
	4000	139.7	7.54	0.40	0.55	0.69	128.7	8.50	0.39	0.55	0.70	117.5	9.60	0.37	0.55	0.72	105.4	10.82	0.35	0.55	0.74
	4800	145.4	7.58	0.42	0.58	0.75	134.0	8.56	0.41	0.59	0.76	122.3	9.65	0.39	0.59	0.78	109.7	10.88	0.38	0.60	0.82

10 TON HIGH EFFICIENCY KGA120H4B (1ST STAGE) - CONSTANT AIR VOLUME

Entering Wet Bulb Temperature	Total Air Volume	Outdoor Air Temperature Entering Outdoor Coil																			
		65°F					75°F					85°F					95°F				
		Total Cool Cap.	Comp. Motor Input	Sensible To Total Ratio (S/T)			Total Cool Cap.	Comp. Motor Input	Sensible To Total Ratio (S/T)			Total Cool Cap.	Comp. Motor Input	Sensible To Total Ratio (S/T)			Total Cool Cap.	Comp. Motor Input	Sensible To Total Ratio (S/T)		
				Dry Bulb					Dry Bulb					Dry Bulb					Dry Bulb		
cfm	kBtuh	kW	75°F	80°F	85°F	kBtuh	kW	75°F	80°F	85°F	kBtuh	kW	75°F	80°F	85°F	kBtuh	kW	75°F	80°F	85°F	
63°F	3200	67.0	2.76	0.66	0.80	0.95	64.0	3.14	0.67	0.81	0.97	60.6	3.55	0.68	0.83	0.99	57.1	4.01	0.68	0.85	1.00
	4000	70.5	2.80	0.71	0.88	1.00	67.2	3.17	0.72	0.90	1.00	63.7	3.58	0.73	0.93	1.00	60.1	4.05	0.75	0.96	1.00
	4800	73.1	2.82	0.77	0.96	1.00	69.8	3.19	0.78	0.98	1.00	66.1	3.60	0.80	1.00	1.00	62.6	4.07	0.82	1.00	1.00
67°F	3200	71.0	2.80	0.53	0.64	0.76	67.8	3.17	0.53	0.65	0.78	64.3	3.59	0.53	0.66	0.79	60.8	4.05	0.53	0.66	0.81
	4000	74.7	2.83	0.56	0.69	0.84	71.2	3.21	0.56	0.70	0.86	67.5	3.62	0.57	0.71	0.89	63.8	4.08	0.57	0.73	0.91
	4800	77.3	2.86	0.58	0.74	0.92	73.8	3.23	0.59	0.76	0.95	69.9	3.64	0.6	0.77	0.98	65.9	4.11	0.61	0.80	1.00
71°F	3200	75.3	2.84	0.41	0.52	0.62	71.9	3.21	0.40	0.52	0.63	68.3	3.63	0.40	0.51	0.64	64.6	4.09	0.39	0.52	0.65
	4000	78.7	2.87	0.42	0.54	0.67	75.2	3.25	0.41	0.55	0.68	71.3	3.66	0.42	0.54	0.69	67.5	4.13	0.41	0.56	0.70
	4800	81.3	2.90	0.43	0.57	0.71	77.6	3.28	0.43	0.58	0.73	73.8	3.69	0.43	0.59	0.75	69.6	4.15	0.43	0.60	0.77

10 TON HIGH EFFICIENCY KGA120H4B (2ND STAGE) - CONSTANT AIR VOLUME

Entering Wet Bulb Temperature	Total Air Volume	Outdoor Air Temperature Entering Outdoor Coil																			
		85°F					95°F					105°F					115°F				
		Total Cool Cap.	Comp. Motor Input	Sensible To Total Ratio (S/T)			Total Cool Cap.	Comp. Motor Input	Sensible To Total Ratio (S/T)			Total Cool Cap.	Comp. Motor Input	Sensible To Total Ratio (S/T)			Total Cool Cap.	Comp. Motor Input	Sensible To Total Ratio (S/T)		
				Dry Bulb					Dry Bulb					Dry Bulb					Dry Bulb		
cfm	kBtuh	kW	75°F	80°F	85°F	kBtuh	kW	75°F	80°F	85°F	kBtuh	kW	75°F	80°F	85°F	kBtuh	kW	75°F	80°F	85°F	
63°F	3200	118.9	7.05	0.68	0.84	1.00	112.1	7.96	0.69	0.86	1.00	104.6	9.00	0.71	0.89	1.00	96.6	10.17	0.72	0.93	1.00
	4000	124.9	7.11	0.74	0.94	1.00	117.7	8.03	0.76	0.97	1.00	110.0	9.05	0.78	1.00	1.00	102.2	10.23	0.80	1.00	1.00
	4800	129.9	7.17	0.80	1.00	1.00	123.0	8.08	0.83	1.00	1.00	115.7	9.12	0.86	1.00	1.00	108.0	10.30	0.90	1.00	1.00
67°F	3200	126.5	7.12	0.53	0.66	0.80	119.2	8.03	0.53	0.67	0.82	111.4	9.07	0.53	0.68	0.85	103.4	10.25	0.54	0.70	0.89
	4000	132.6	7.19	0.57	0.72	0.90	124.8	8.10	0.57	0.73	0.93	116.7	9.13	0.58	0.75	0.97	108.0	10.30	0.59	0.78	1.00
	4800	137.1	7.25	0.60	0.78	0.99	128.9	8.15	0.61	0.80	1.00	120.2	9.18	0.61	0.83	1.00	111.3	10.34	0.63	0.87	1.00
71°F	3200	134.2	7.21	0.40	0.53	0.64	126.6	8.12	0.39	0.52	0.65	118.5	9.15	0.39	0.52	0.66	110.0	10.32	0.39	0.54	0.68
	4000	140.0	7.28	0.41	0.56	0.70	132.0	8.19	0.41	0.57	0.71	123.5	9.22	0.41	0.57	0.73	114.7	10.38	0.41	0.58	0.76
	4800	144.5	7.34	0.43	0.6	0.76	136.2	8.24	0.43	0.61	0.78	127.2	9.27	0.43	0.61	0.81	117.9	10.43	0.42	0.63	0.84

RATINGS

NOTE – For Temperatures and Capacities not shown in tables, see bulletin – Cooling Unit Rating Table Correction Factor Data in Miscellaneous Engineering Data section.

12.5 TON STANDARD EFFICIENCY KGA150S4B (1ST STAGE) - CONSTANT AIR VOLUME

Entering Wet Bulb Temperature	Total Air Volume	Outdoor Air Temperature Entering Outdoor Coil																			
		65°F					75°F					85°F					95°F				
		Total Cool Cap.	Comp. Motor Input	Sensible To Total Ratio (S/T) Dry Bulb			Total Cool Cap.	Comp. Motor Input	Sensible To Total Ratio (S/T) Dry Bulb			Total Cool Cap.	Comp. Motor Input	Sensible To Total Ratio (S/T) Dry Bulb			Total Cool Cap.	Comp. Motor Input	Sensible To Total Ratio (S/T) Dry Bulb		
				75°F	80°F	85°F			75°F	80°F	85°F			75°F	80°F	85°F			75°F	80°F	85°F
		cfm	kBtuh	kW	75°F	80°F	85°F	kBtuh	kW	75°F	80°F	85°F	kBtuh	kW	75°F	80°F	85°F	kBtuh	kW	75°F	80°F
63°F	3800	80.2	3.25	0.63	0.78	0.94	74.7	3.64	0.63	0.79	0.96	69.1	4.08	0.64	0.81	0.99	63.1	4.58	0.64	0.83	1.00
	4400	83.6	3.27	0.66	0.83	1.00	77.8	3.66	0.67	0.85	1.00	72.0	4.11	0.67	0.87	1.00	65.9	4.60	0.69	0.91	1.00
	5000	86.3	3.29	0.69	0.88	1.00	80.5	3.69	0.71	0.91	1.00	74.3	4.12	0.71	0.94	1.00	68.1	4.62	0.74	0.98	1.00
67°F	3800	85.9	3.28	0.50	0.62	0.74	80.3	3.68	0.50	0.62	0.75	74.4	4.12	0.49	0.62	0.77	68.2	4.62	0.48	0.62	0.79
	4400	89.3	3.31	0.52	0.64	0.79	83.4	3.71	0.52	0.65	0.81	77.4	4.15	0.51	0.65	0.83	71.0	4.65	0.51	0.66	0.87
	5000	92.1	3.33	0.54	0.67	0.84	86.2	3.73	0.53	0.68	0.86	79.7	4.17	0.53	0.69	0.90	73.2	4.67	0.53	0.71	0.93
71°F	3800	91.7	3.32	0.38	0.49	0.60	85.8	3.73	0.38	0.49	0.60	79.8	4.17	0.36	0.49	0.60	73.3	4.67	0.35	0.48	0.61
	4400	95.2	3.35	0.40	0.51	0.62	89.1	3.76	0.39	0.51	0.63	82.8	4.20	0.37	0.51	0.63	76.2	4.70	0.36	0.50	0.64
	5000	97.9	3.37	0.40	0.53	0.65	91.7	3.78	0.40	0.53	0.66	85.2	4.22	0.38	0.53	0.67	78.4	4.72	0.37	0.53	0.68

12.5 TON STANDARD EFFICIENCY KGA150S4B (2ND STAGE) - CONSTANT AIR VOLUME

Entering Wet Bulb Temperature	Total Air Volume	Outdoor Air Temperature Entering Outdoor Coil																			
		85°F					95°F					105°F					115°F				
		Total Cool Cap.	Comp. Motor Input	Sensible To Total Ratio (S/T) Dry Bulb			Total Cool Cap.	Comp. Motor Input	Sensible To Total Ratio (S/T) Dry Bulb			Total Cool Cap.	Comp. Motor Input	Sensible To Total Ratio (S/T) Dry Bulb			Total Cool Cap.	Comp. Motor Input	Sensible To Total Ratio (S/T) Dry Bulb		
				75°F	80°F	85°F			75°F	80°F	85°F			75°F	80°F	85°F			75°F	80°F	85°F
		cfm	kBtuh	kW	75°F	80°F	85°F	kBtuh	kW	75°F	80°F	85°F	kBtuh	kW	75°F	80°F	85°F	kBtuh	kW	75°F	80°F
63°F	3800	139.7	8.40	0.69	0.85	1.00	127.4	9.42	0.70	0.87	1.00	114.8	10.59	0.71	0.90	1.00	101.5	11.94	0.72	0.94	1.00
	4400	145.4	8.45	0.73	0.90	1.00	132.9	9.47	0.74	0.93	1.00	119.8	10.64	0.76	0.97	1.00	106.2	11.99	0.79	1.00	1.00
	5000	150.3	8.49	0.77	0.96	1.00	137.4	9.52	0.79	0.99	1.00	124.4	10.69	0.81	1.00	1.00	111.7	12.05	0.84	1.00	1.00
67°F	3800	150.3	8.49	0.53	0.67	0.82	137.9	9.52	0.53	0.68	0.84	124.7	10.69	0.52	0.69	0.86	111.1	12.04	0.51	0.71	0.90
	4400	156.2	8.55	0.56	0.71	0.87	143.3	9.57	0.55	0.72	0.89	129.7	10.75	0.55	0.74	0.93	115.4	12.10	0.55	0.76	0.97
	5000	161.1	8.59	0.58	0.75	0.92	147.6	9.62	0.58	0.77	0.95	133.7	10.79	0.59	0.79	0.99	119.1	12.14	0.59	0.82	1.00
71°F	3800	161.9	8.60	0.39	0.53	0.66	148.7	9.63	0.38	0.52	0.66	135.1	10.80	0.36	0.52	0.67	120.8	12.15	0.34	0.51	0.68
	4400	167.4	8.65	0.41	0.55	0.69	153.9	9.68	0.39	0.55	0.70	139.8	10.85	0.38	0.54	0.72	124.9	12.20	0.36	0.55	0.74
	5000	171.9	8.70	0.42	0.57	0.73	158.0	9.73	0.41	0.58	0.75	143.5	10.90	0.39	0.58	0.77	128.5	12.24	0.37	0.59	0.80

RATINGS

NOTE - For Temperatures and Capacities not shown in tables, see bulletin - Cooling Unit Rating Table Correction Factor Data in Miscellaneous Engineering Data section.

7.5 TON STANDARD EFFICIENCY KGA092S4M (1ST STAGE) - SINGLE ZONE VAV SUPPLY FAN SUPPLY AIR BLOWER

Entering Wet Bulb Temperature	Total Air Volume	Outdoor Air Temperature Entering Outdoor Coil																			
		65°F					75°F					85°F					95°F				
		Total Cool Cap.	Comp. Motor Input	Sensible To Total Ratio (S/T) Dry Bulb			Total Cool Cap.	Comp. Motor Input	Sensible To Total Ratio (S/T) Dry Bulb			Total Cool Cap.	Comp. Motor Input	Sensible To Total Ratio (S/T) Dry Bulb			Total Cool Cap.	Comp. Motor Input	Sensible To Total Ratio (S/T) Dry Bulb		
		cfm	kBtuh	kW	75°F	80°F	85°F	kBtuh	kW	75°F	80°F	85°F	kBtuh	kW	75°F	80°F	85°F	kBtuh	kW	75°F	80°F
63°F	1680	55.5	2.71	0.63	0.73	0.82	53.2	3.05	0.63	0.73	0.83	50.8	3.42	0.64	0.74	0.84	48.0	3.86	0.64	0.75	0.86
	2100	59.7	2.75	0.66	0.76	0.87	57.2	3.08	0.66	0.77	0.88	54.3	3.45	0.66	0.78	0.9	51.3	3.88	0.67	0.8	0.92
	2520	62.7	2.77	0.68	0.80	0.92	60.0	3.10	0.69	0.81	0.93	57.0	3.47	0.69	0.82	0.95	53.7	3.90	0.70	0.84	0.97
67°F	1680	58.2	2.73	0.51	0.61	0.70	55.8	3.06	0.51	0.61	0.70	53.2	3.44	0.52	0.61	0.71	50.4	3.88	0.52	0.62	0.72
	2100	62.5	2.77	0.53	0.63	0.73	59.9	3.09	0.54	0.64	0.74	57.1	3.47	0.54	0.64	0.75	53.9	3.90	0.54	0.65	0.76
	2520	65.9	2.79	0.55	0.65	0.77	63.0	3.12	0.55	0.66	0.78	59.9	3.49	0.55	0.67	0.79	56.5	3.93	0.56	0.68	0.81
71°F	1680	60.8	2.75	0.41	0.49	0.58	58.4	3.08	0.40	0.49	0.59	55.6	3.46	0.40	0.5	0.59	52.6	3.89	0.40	0.50	0.60
	2100	65.3	2.79	0.42	0.52	0.61	62.6	3.11	0.42	0.52	0.61	59.6	3.49	0.42	0.52	0.62	56.3	3.92	0.41	0.53	0.63
	2520	68.8	2.81	0.43	0.53	0.63	65.9	3.14	0.43	0.54	0.64	62.6	3.51	0.43	0.54	0.65	59.1	3.95	0.42	0.55	0.66

7.5 TON STANDARD EFFICIENCY KGA092S4M (2ND STAGE) - SINGLE ZONE VAV SUPPLY FAN SUPPLY AIR BLOWER

Entering Wet Bulb Temperature	Total Air Volume	Outdoor Air Temperature Entering Outdoor Coil																			
		85°F					95°F					105°F					115°F				
		Total Cool Cap.	Comp. Motor Input	Sensible To Total Ratio (S/T) Dry Bulb			Total Cool Cap.	Comp. Motor Input	Sensible To Total Ratio (S/T) Dry Bulb			Total Cool Cap.	Comp. Motor Input	Sensible To Total Ratio (S/T) Dry Bulb			Total Cool Cap.	Comp. Motor Input	Sensible To Total Ratio (S/T) Dry Bulb		
		cfm	kBtuh	kW	75°F	80°F	85°F	kBtuh	kW	75°F	80°F	85°F	kBtuh	kW	75°F	80°F	85°F	kBtuh	kW	75°F	80°F
63°F	2400	86.0	5.76	0.68	0.82	0.96	80.6	6.50	0.69	0.84	0.98	74.8	7.36	0.71	0.87	1.00	68.6	8.33	0.73	0.90	1.00
	3000	90.8	5.80	0.73	0.89	1.00	85.0	6.54	0.74	0.92	1.00	78.8	7.40	0.76	0.95	1.00	72.2	8.38	0.79	0.98	1.00
	3600	94.4	5.82	0.77	0.95	1.00	88.3	6.57	0.79	0.98	1.00	82.0	7.43	0.82	0.99	1.00	75.5	8.42	0.85	1.00	1.00
67°F	2400	90.7	5.79	0.54	0.66	0.78	85.2	6.54	0.54	0.67	0.80	79.3	7.40	0.55	0.69	0.83	72.7	8.38	0.56	0.70	0.86
	3000	96.0	5.83	0.57	0.70	0.85	89.9	6.58	0.57	0.72	0.88	83.5	7.45	0.58	0.74	0.91	76.7	8.43	0.59	0.77	0.95
	3600	99.7	5.85	0.59	0.75	0.92	93.4	6.61	0.60	0.77	0.95	86.6	7.48	0.61	0.79	0.98	79.3	8.47	0.63	0.83	1.00
71°F	2400	95.0	5.82	0.41	0.53	0.64	89.5	6.58	0.41	0.53	0.65	83.3	7.44	0.4	0.54	0.66	76.7	8.43	0.40	0.55	0.68
	3000	100.7	5.86	0.43	0.56	0.68	94.5	6.62	0.42	0.56	0.70	87.9	7.49	0.41	0.57	0.72	80.8	8.48	0.41	0.58	0.74
	3600	104.7	5.89	0.43	0.58	0.72	98.1	6.65	0.43	0.59	0.74	91.2	7.52	0.43	0.60	0.77	83.8	8.52	0.43	0.62	0.80

7.5 TON HIGH EFFICIENCY KGA092H4M (1ST STAGE) - SINGLE ZONE VAV SUPPLY FAN SUPPLY AIR BLOWER

Entering Wet Bulb Temperature	Total Air Volume	Outdoor Air Temperature Entering Outdoor Coil																			
		65°F					75°F					85°F					95°F				
		Total Cool Cap.	Comp. Motor Input	Sensible To Total Ratio (S/T) Dry Bulb			Total Cool Cap.	Comp. Motor Input	Sensible To Total Ratio (S/T) Dry Bulb			Total Cool Cap.	Comp. Motor Input	Sensible To Total Ratio (S/T) Dry Bulb			Total Cool Cap.	Comp. Motor Input	Sensible To Total Ratio (S/T) Dry Bulb		
		cfm	kBtuh	kW	75°F	80°F	85°F	kBtuh	kW	75°F	80°F	85°F	kBtuh	kW	75°F	80°F	85°F	kBtuh	kW	75°F	80°F
63°F	1680	43.6	1.94	0.59	0.69	0.81	41.9	2.20	0.59	0.70	0.82	40.0	2.49	0.59	0.71	0.84	38.0	2.81	0.59	0.72	0.86
	2100	46.8	1.95	0.61	0.74	0.88	44.8	2.21	0.61	0.76	0.90	42.8	2.49	0.63	0.77	0.92	40.6	2.82	0.63	0.79	0.95
	2520	49.1	1.96	0.65	0.80	0.96	47.0	2.21	0.66	0.81	0.98	44.8	2.50	0.67	0.83	1.00	42.5	2.82	0.68	0.86	1.00
67°F	1680	46.5	1.95	0.48	0.56	0.65	44.7	2.21	0.48	0.56	0.66	42.8	2.49	0.47	0.57	0.67	40.7	2.82	0.48	0.57	0.68
	2100	49.6	1.96	0.49	0.59	0.70	47.5	2.22	0.49	0.59	0.72	45.4	2.50	0.49	0.60	0.73	43.1	2.82	0.50	0.60	0.75
	2520	52.0	1.97	0.51	0.62	0.76	49.9	2.22	0.52	0.63	0.77	47.6	2.50	0.51	0.64	0.79	45.1	2.82	0.52	0.65	0.82
71°F	1680	49.4	1.96	0.38	0.46	0.54	47.5	2.22	0.38	0.46	0.54	45.5	2.50	0.38	0.46	0.55	43.4	2.82	0.37	0.46	0.55
	2100	52.6	1.97	0.38	0.48	0.57	50.6	2.22	0.38	0.48	0.57	48.4	2.51	0.38	0.48	0.57	46.0	2.83	0.38	0.48	0.58
	2520	54.9	1.98	0.39	0.49	0.59	52.6	2.23	0.39	0.50	0.60	50.3	2.51	0.39	0.50	0.61	47.8	2.83	0.39	0.50	0.63

7.5 TON HIGH EFFICIENCY KGA092H4M (2ND STAGE) - SINGLE ZONE VAV SUPPLY FAN SUPPLY AIR BLOWER

Entering Wet Bulb Temperature	Total Air Volume	Outdoor Air Temperature Entering Outdoor Coil																			
		85°F					95°F					105°F					115°F				
		Total Cool Cap.	Comp. Motor Input	Sensible To Total Ratio (S/T) Dry Bulb			Total Cool Cap.	Comp. Motor Input	Sensible To Total Ratio (S/T) Dry Bulb			Total Cool Cap.	Comp. Motor Input	Sensible To Total Ratio (S/T) Dry Bulb			Total Cool Cap.	Comp. Motor Input	Sensible To Total Ratio (S/T) Dry Bulb		
		cfm	kBtuh	kW	75°F	80°F	85°F	kBtuh	kW	75°F	80°F	85°F	kBtuh	kW	75°F	80°F	85°F	kBtuh	kW	75°F	80°F
63°F	2400	87.9	4.98	0.68	0.83	0.99	83.4	5.62	0.69	0.85	1.00	78.4	6.36	0.71	0.88	1.00	73.1	7.23	0.73	0.92	1.00
	3000	92.4	4.99	0.74	0.92	1.00	87.6	5.63	0.76	0.96	1.00	82.3	6.37	0.78	0.98	1.00	76.8	7.22	0.80	1.00	1.00
	3600	96.0	5.00	0.80	1.00	1.00	91.2	5.64	0.82	1.00	1.00	86.4	6.37	0.85	1.00	1.00	81.2	7.22	0.88	1.00	1.00
67°F	2400	93.3	4.99	0.54	0.66	0.79	88.4	5.63	0.54	0.67	0.81	83.3	6.37	0.55	0.68	0.84	78.0	7.23	0.56	0.71	0.88
	3000	97.9	5.00	0.57	0.71	0.88	93.0	5.64	0.58	0.73	0.91	87.2	6.37	0.59	0.75	0.95	81.1	7.22	0.59	0.78	0.99
	3600	101.4	5.01	0.61	0.77	0.97	95.6	5.64	0.61	0.79	1.00	90.0	6.38	0.62	0.82	1.00	83.6	7.22	0.64	0.86	1.00
71°F	2400	99.1	5.00	0.41	0.52	0.64	94.0	5.64	0.41	0.53	0.65	88.6	6.37	0.40	0.54	0.66	82.7	7.22	0.41	0.55	0.68
	3000	103.3	5.01	0.42	0.56	0.69	98.0	5.65	0.42	0.57	0.71	92.2	6.38	0.42	0.58	0.73	86.0	7.23	0.43	0.59	0.75
	3600	106.9	5.02	0.44	0.60	0.75	101.2	5.66	0.43	0.60	0.77	95.0	6.38	0.44	0.61	0.80	88.3	7.22	0.44	0.63	0.84

RATINGS

NOTE – For Temperatures and Capacities not shown in tables, see bulletin – Cooling Unit Rating Table Correction Factor Data in Miscellaneous Engineering Data section.

8.5 TON STANDARD EFFICIENCY KGA102S4M (1ST STAGE) - SINGLE ZONE VAV SUPPLY FAN SUPPLY AIR BLOWER

Entering Wet Bulb Temperature	Total Air Volume	Outdoor Air Temperature Entering Outdoor Coil																			
		65°F					75°F					85°F					95°F				
		Total Cool Cap.	Comp. Motor Input	Sensible To Total Ratio (S/T)			Total Cool Cap.	Comp. Motor Input	Sensible To Total Ratio (S/T)			Total Cool Cap.	Comp. Motor Input	Sensible To Total Ratio (S/T)			Total Cool Cap.	Comp. Motor Input	Sensible To Total Ratio (S/T)		
				Dry Bulb					Dry Bulb					Dry Bulb					Dry Bulb		
cfm	kBtuh	kW	75°F	80°F	85°F	kBtuh	kW	75°F	80°F	85°F	kBtuh	kW	75°F	80°F	85°F	kBtuh	kW	75°F	80°F	85°F	
63°F	1920	51.1	2.42	0.62	0.73	0.83	48.0	2.69	0.62	0.73	0.84	44.6	3.00	0.61	0.73	0.85	41.1	3.37	0.61	0.74	0.87
	2400	55.7	2.42	0.65	0.77	0.89	52.2	2.70	0.65	0.78	0.90	48.7	3.01	0.65	0.79	0.92	44.8	3.38	0.65	0.80	0.95
	2880	59.1	2.43	0.68	0.81	0.95	55.5	2.70	0.68	0.82	0.96	51.6	3.01	0.69	0.84	0.98	47.5	3.38	0.69	0.86	1.00
67°F	1920	54.4	2.42	0.51	0.60	0.70	51.2	2.69	0.49	0.60	0.70	47.8	3.01	0.48	0.59	0.70	44.1	3.38	0.47	0.59	0.70
	2400	59.1	2.43	0.52	0.63	0.74	55.6	2.70	0.52	0.63	0.75	51.9	3.01	0.51	0.63	0.75	48.0	3.39	0.50	0.63	0.76
	2880	62.7	2.43	0.54	0.66	0.78	59.0	2.71	0.54	0.66	0.79	55.1	3.02	0.53	0.67	0.80	50.8	3.39	0.53	0.67	0.82
71°F	1920	57.6	2.42	0.40	0.49	0.58	54.2	2.69	0.38	0.48	0.58	50.8	3.01	0.37	0.47	0.57	47.0	3.38	0.35	0.46	0.57
	2400	62.4	2.43	0.41	0.51	0.61	58.9	2.71	0.40	0.51	0.61	55.1	3.02	0.38	0.5	0.61	51.0	3.40	0.37	0.49	0.61
	2880	66.1	2.44	0.42	0.53	0.64	62.3	2.72	0.41	0.53	0.64	58.3	3.03	0.40	0.52	0.65	54.0	3.41	0.38	0.52	0.65

8.5 TON STANDARD EFFICIENCY KGA102S4M (2ND STAGE) - SINGLE ZONE VAV SUPPLY FAN SUPPLY AIR BLOWER

Entering Wet Bulb Temperature	Total Air Volume	Outdoor Air Temperature Entering Outdoor Coil																			
		85°F					95°F					105°F					115°F				
		Total Cool Cap.	Comp. Motor Input	Sensible To Total Ratio (S/T)			Total Cool Cap.	Comp. Motor Input	Sensible To Total Ratio (S/T)			Total Cool Cap.	Comp. Motor Input	Sensible To Total Ratio (S/T)			Total Cool Cap.	Comp. Motor Input	Sensible To Total Ratio (S/T)		
				Dry Bulb					Dry Bulb					Dry Bulb					Dry Bulb		
cfm	kBtuh	kW	75°F	80°F	85°F	kBtuh	kW	75°F	80°F	85°F	kBtuh	kW	75°F	80°F	85°F	kBtuh	kW	75°F	80°F	85°F	
63°F	2720	95.0	6.52	0.67	0.82	0.96	87.4	7.34	0.67	0.83	0.99	79.3	8.28	0.68	0.85	1.00	70.8	9.42	0.69	0.88	1.00
	3400	101.3	6.54	0.72	0.89	1.00	93.1	7.35	0.73	0.91	1.00	84.6	8.30	0.74	0.94	1.00	75.4	9.43	0.76	0.98	1.00
	4080	105.8	6.55	0.77	0.96	1.00	97.1	7.37	0.78	0.98	1.00	88.4	8.31	0.80	1.00	1.00	79.8	9.44	0.83	1.00	1.00
67°F	2720	101.4	6.54	0.52	0.65	0.78	93.5	7.34	0.52	0.66	0.80	85.3	8.30	0.50	0.66	0.82	76.5	9.43	0.50	0.67	0.84
	3400	108.0	6.56	0.55	0.70	0.85	99.6	7.37	0.55	0.71	0.87	90.8	8.31	0.55	0.72	0.90	81.5	9.43	0.54	0.74	0.94
	4080	112.7	6.57	0.58	0.75	0.92	103.9	7.37	0.58	0.76	0.95	94.8	8.33	0.58	0.78	0.98	85.1	9.46	0.59	0.81	1.00
71°F	2720	107.3	6.56	0.38	0.52	0.63	99.5	7.37	0.37	0.51	0.64	91.0	8.31	0.35	0.50	0.64	82.1	9.45	0.33	0.49	0.65
	3400	114.3	6.58	0.40	0.54	0.68	105.7	7.39	0.39	0.54	0.69	96.6	8.34	0.37	0.54	0.70	87.2	9.46	0.35	0.54	0.72
	4080	119.3	6.60	0.41	0.58	0.73	110.2	7.40	0.4	0.58	0.74	100.80	8.36	0.39	0.58	0.76	90.9	9.49	0.38	0.59	0.78

8.5 TON HIGH EFFICIENCY KGA102H4M (1ST STAGE) - SINGLE ZONE VAV SUPPLY FAN SUPPLY AIR BLOWER

Entering Wet Bulb Temperature	Total Air Volume	Outdoor Air Temperature Entering Outdoor Coil																			
		65°F					75°F					85°F					95°F				
		Total Cool Cap.	Comp. Motor Input	Sensible To Total Ratio (S/T)			Total Cool Cap.	Comp. Motor Input	Sensible To Total Ratio (S/T)			Total Cool Cap.	Comp. Motor Input	Sensible To Total Ratio (S/T)			Total Cool Cap.	Comp. Motor Input	Sensible To Total Ratio (S/T)		
				Dry Bulb					Dry Bulb					Dry Bulb					Dry Bulb		
cfm	kBtuh	kW	75°F	80°F	85°F	kBtuh	kW	75°F	80°F	85°F	kBtuh	kW	75°F	80°F	85°F	kBtuh	kW	75°F	80°F	85°F	
63°F	1920	49.6	2.15	0.56	0.68	0.81	47.0	2.44	0.56	0.69	0.83	44.4	2.76	0.56	0.70	0.84	41.5	3.12	0.56	0.71	0.87
	2400	53.3	2.16	0.59	0.74	0.90	50.5	2.45	0.60	0.76	0.93	47.5	2.76	0.60	0.77	0.95	44.3	3.13	0.61	0.79	0.98
	2880	55.8	2.17	0.63	0.81	0.99	53.0	2.45	0.64	0.83	1.00	49.8	2.77	0.66	0.85	1.00	46.5	3.13	0.67	0.88	1.00
67°F	1920	53.0	2.16	0.46	0.54	0.64	50.5	2.45	0.45	0.54	0.65	47.7	2.76	0.45	0.54	0.65	44.7	3.13	0.44	0.54	0.66
	2400	56.7	2.17	0.47	0.57	0.70	53.9	2.46	0.47	0.57	0.72	50.8	2.77	0.46	0.58	0.73	47.6	3.13	0.46	0.58	0.75
	2880	59.4	2.18	0.49	0.61	0.77	56.4	2.46	0.49	0.62	0.78	53.2	2.78	0.49	0.63	0.80	49.8	3.14	0.50	0.64	0.84
71°F	1920	56.6	2.17	0.36	0.44	0.52	54.0	2.46	0.35	0.44	0.52	51.0	2.77	0.34	0.44	0.52	48.0	3.13	0.33	0.43	0.53
	2400	60.3	2.18	0.37	0.46	0.55	57.3	2.46	0.36	0.46	0.55	54.2	2.78	0.35	0.46	0.56	50.9	3.14	0.34	0.46	0.56
	2880	63.0	2.19	0.38	0.48	0.58	59.7	2.47	0.37	0.48	0.59	56.5	2.79	0.36	0.48	0.60	53.0	3.14	0.36	0.48	0.62

8.5 TON HIGH EFFICIENCY KGA102H4M (2ND STAGE) - SINGLE ZONE VAV SUPPLY FAN SUPPLY AIR BLOWER

Entering Wet Bulb Temperature	Total Air Volume	Outdoor Air Temperature Entering Outdoor Coil																			
		85°F					95°F					105°F					115°F				
		Total Cool Cap.	Comp. Motor Input	Sensible To Total Ratio (S/T)			Total Cool Cap.	Comp. Motor Input	Sensible To Total Ratio (S/T)			Total Cool Cap.	Comp. Motor Input	Sensible To Total Ratio (S/T)			Total Cool Cap.	Comp. Motor Input	Sensible To Total Ratio (S/T)		
				Dry Bulb					Dry Bulb					Dry Bulb					Dry Bulb		
cfm	kBtuh	kW	75°F	80°F	85°F	kBtuh	kW	75°F	80°F	85°F	kBtuh	kW	75°F	80°F	85°F	kBtuh	kW	75°F	80°F	85°F	
63°F	2720	98.9	5.54	0.70	0.85	1.00	92.5	6.27	0.71	0.87	1.00	85.7	7.10	0.71	0.90	1.00	78.6	8.09	0.73	0.94	1.00
	3400	104.2	5.56	0.76	0.95	1.00	97.5	6.27	0.77	0.98	1.00	90.4	7.11	0.79	1.00	1.00	83.6	8.08	0.82	1.00	1.00
	4080	108.6	5.56	0.82	1.00	1.00	102.3	6.28	0.84	1.00	1.00	95.9	7.12	0.87	1.00	1.00	88.9	8.08	0.91	1.00	1.00
67°F	2720	105.6	5.56	0.53	0.67	0.81	98.9	6.28	0.53	0.68	0.83	91.8	7.11	0.54	0.69	0.87	84.4	8.08	0.55	0.71	0.90
	3400	110.9	5.57	0.58	0.74	0.91	103.8	6.29	0.59	0.75	0.94	96.4	7.12	0.59	0.77	0.97	88.5	8.08	0.59	0.79	1.00
	4080	114.8	5.58	0.61	0.80	0.99	107.2	6.30	0.62	0.82	1.00	99.6	7.12	0.63	0.85	1.00	91.5	8.08	0.63	0.88	1.00
71°F	2720	112.1	5.57	0.40	0.53	0.65	105.2	6.29	0.39	0.53	0.66	98.1	7.12	0.38	0.53	0.67	90.3	8.08	0.38	0.54	0.69
	3400	117.6	5.59	0.42	0.57	0.72	110.4	6.30	0.41	0.58	0.73	102.7	7.12	0.41	0.58	0.75	94.3	8.08	0.40	0.59	0.77
	4080	121.7	5.60	0.44	0.61	0.77	113.9	6.31	0.43	0.61	0.79	105.9	7.13	0.42	0.62	0.83	97.4	8.08	0.43	0.63	0.86

RATINGS

NOTE – For Temperatures and Capacities not shown in tables, see bulletin – Cooling Unit Rating Table Correction Factor Data in Miscellaneous Engineering Data section.

10 TON STANDARD EFFICIENCY KGA120S4M (1ST STAGE) - SINGLE ZONE VAV SUPPLY FAN SUPPLY AIR BLOWER

Entering Wet Bulb Temperature	Total Air Volume	Outdoor Air Temperature Entering Outdoor Coil																			
		65°F					75°F					85°F					95°F				
		Total Cool Cap.	Comp. Motor Input	Sensible To Total Ratio (S/T)			Total Cool Cap.	Comp. Motor Input	Sensible To Total Ratio (S/T)			Total Cool Cap.	Comp. Motor Input	Sensible To Total Ratio (S/T)			Total Cool Cap.	Comp. Motor Input	Sensible To Total Ratio (S/T)		
				Dry Bulb					Dry Bulb					Dry Bulb					Dry Bulb		
cfm	kBtuh	kW	75°F	80°F	85°F	kBtuh	kW	75°F	80°F	85°F	kBtuh	kW	75°F	80°F	85°F	kBtuh	kW	75°F	80°F	85°F	
63°F	2240	56.7	2.72	0.62	0.73	0.84	53.0	3.05	0.62	0.73	0.85	49.0	3.43	0.61	0.73	0.86	44.7	3.87	0.60	0.74	0.88
	2800	61.6	2.73	0.66	0.78	0.90	57.5	3.06	0.66	0.79	0.92	53.2	3.45	0.65	0.80	0.93	48.5	3.90	0.65	0.81	0.96
	3360	65.1	2.74	0.69	0.83	0.96	60.8	3.08	0.70	0.84	0.98	56.2	3.47	0.70	0.85	1.00	51.5	3.92	0.70	0.87	1.00
67°F	2240	61.1	2.73	0.50	0.60	0.70	57.2	3.06	0.49	0.60	0.70	53.1	3.45	0.48	0.59	0.70	48.7	3.90	0.46	0.58	0.71
	2800	66.1	2.74	0.53	0.64	0.75	61.9	3.09	0.51	0.64	0.75	57.5	3.48	0.51	0.63	0.76	52.7	3.93	0.49	0.63	0.77
	3360	69.8	2.75	0.55	0.67	0.80	65.4	3.11	0.54	0.67	0.80	60.7	3.50	0.53	0.68	0.82	55.7	3.95	0.52	0.68	0.84
71°F	2240	65.5	2.73	0.40	0.49	0.58	61.4	3.08	0.38	0.48	0.58	57.2	3.48	0.36	0.47	0.57	52.7	3.93	0.34	0.45	0.56
	2800	70.6	2.76	0.41	0.51	0.62	66.3	3.10	0.39	0.51	0.61	61.7	3.50	0.38	0.50	0.61	56.8	3.96	0.35	0.49	0.61
	3360	74.5	2.76	0.42	0.54	0.65	69.8	3.12	0.40	0.53	0.65	65.0	3.52	0.39	0.52	0.66	59.9	3.98	0.37	0.52	0.66

10 TON STANDARD EFFICIENCY KGA120S4M (2ND STAGE) - SINGLE ZONE VAV SUPPLY FAN SUPPLY AIR BLOWER

Entering Wet Bulb Temperature	Total Air Volume	Outdoor Air Temperature Entering Outdoor Coil																			
		85°F					95°F					105°F					115°F				
		Total Cool Cap.	Comp. Motor Input	Sensible To Total Ratio (S/T)			Total Cool Cap.	Comp. Motor Input	Sensible To Total Ratio (S/T)			Total Cool Cap.	Comp. Motor Input	Sensible To Total Ratio (S/T)			Total Cool Cap.	Comp. Motor Input	Sensible To Total Ratio (S/T)		
				Dry Bulb					Dry Bulb					Dry Bulb					Dry Bulb		
cfm	kBtuh	kW	75°F	80°F	85°F	kBtuh	kW	75°F	80°F	85°F	kBtuh	kW	75°F	80°F	85°F	kBtuh	kW	75°F	80°F	85°F	
63°F	3200	114.0	7.38	0.68	0.83	0.98	104.2	8.32	0.68	0.85	1.00	93.9	9.38	0.68	0.87	1.00	83.2	10.57	0.69	0.91	1.00
	4000	121.0	7.42	0.73	0.92	1.00	111.1	8.38	0.74	0.94	1.00	100.5	9.44	0.76	0.97	1.00	89.4	10.64	0.78	1.00	1.00
	4800	126.9	7.46	0.79	0.99	1.00	116.4	8.42	0.81	1.00	1.00	106.5	9.50	0.83	1.00	1.00	96.0	10.71	0.86	1.00	1.00
67°F	3200	123.1	7.43	0.52	0.66	0.79	113.0	8.39	0.51	0.66	0.81	102.5	9.46	0.50	0.67	0.83	91.5	10.66	0.49	0.67	0.87
	4000	130.6	7.48	0.55	0.71	0.88	120.0	8.44	0.55	0.72	0.90	108.8	9.52	0.55	0.74	0.93	97.0	10.73	0.55	0.76	0.98
	4800	136.0	7.51	0.59	0.77	0.95	124.9	8.48	0.59	0.78	0.98	113.3	9.56	0.59	0.81	1.00	101.2	10.77	0.60	0.84	1.00
71°F	3200	131.9	7.49	0.38	0.51	0.64	121.7	8.45	0.36	0.50	0.64	110.7	9.53	0.34	0.50	0.65	99.4	10.75	0.32	0.49	0.65
	4000	139.7	7.54	0.40	0.55	0.69	128.7	8.50	0.39	0.55	0.70	117.5	9.60	0.37	0.55	0.72	105.4	10.82	0.35	0.55	0.74
	4800	145.4	7.58	0.42	0.58	0.75	134.0	8.56	0.41	0.59	0.76	122.3	9.65	0.39	0.59	0.78	109.7	10.88	0.38	0.60	0.82

10 TON HIGH EFFICIENCY KGA120H4M (1ST STAGE) - SINGLE ZONE VAV SUPPLY FAN SUPPLY AIR BLOWER

Entering Wet Bulb Temperature	Total Air Volume	Outdoor Air Temperature Entering Outdoor Coil																			
		65°F					75°F					85°F					95°F				
		Total Cool Cap.	Comp. Motor Input	Sensible To Total Ratio (S/T)			Total Cool Cap.	Comp. Motor Input	Sensible To Total Ratio (S/T)			Total Cool Cap.	Comp. Motor Input	Sensible To Total Ratio (S/T)			Total Cool Cap.	Comp. Motor Input	Sensible To Total Ratio (S/T)		
				Dry Bulb					Dry Bulb					Dry Bulb					Dry Bulb		
cfm	kBtuh	kW	75°F	80°F	85°F	kBtuh	kW	75°F	80°F	85°F	kBtuh	kW	75°F	80°F	85°F	kBtuh	kW	75°F	80°F	85°F	
63°F	2240	60.2	2.71	0.60	0.71	0.82	57.7	3.09	0.60	0.72	0.84	54.8	3.50	0.60	0.72	0.85	51.7	3.97	0.61	0.73	0.87
	2800	64.6	2.75	0.63	0.76	0.90	61.6	3.12	0.63	0.77	0.92	58.6	3.53	0.64	0.79	0.94	55.3	3.99	0.65	0.80	0.96
	3360	67.8	2.77	0.66	0.82	0.97	64.6	3.14	0.67	0.83	0.99	61.2	3.55	0.68	0.85	1.00	57.8	4.02	0.69	0.87	1.00
67°F	2240	64.4	2.74	0.49	0.58	0.67	61.6	3.12	0.49	0.58	0.68	58.7	3.53	0.48	0.58	0.69	55.5	4.00	0.48	0.58	0.70
	2800	68.7	2.78	0.51	0.61	0.73	65.6	3.15	0.51	0.61	0.73	62.2	3.56	0.50	0.61	0.75	58.8	4.03	0.50	0.62	0.77
	3360	71.9	2.81	0.52	0.64	0.78	68.6	3.18	0.52	0.65	0.80	65.1	3.59	0.52	0.66	0.81	61.5	4.06	0.52	0.67	0.83
71°F	2240	68.6	2.78	0.39	0.47	0.55	65.7	3.15	0.38	0.47	0.55	62.6	3.57	0.38	0.47	0.56	59.2	4.03	0.37	0.47	0.56
	2800	72.9	2.82	0.39	0.49	0.59	69.7	3.19	0.39	0.49	0.59	66.4	3.60	0.38	0.49	0.59	62.8	4.07	0.38	0.49	0.60
	3360	76.0	2.85	0.40	0.51	0.62	72.6	3.22	0.39	0.51	0.62	69.3	3.64	0.39	0.53	0.63	65.2	4.10	0.39	0.51	0.64

10 TON HIGH EFFICIENCY KGA120H4M (2ND STAGE) - SINGLE ZONE VAV SUPPLY FAN SUPPLY AIR BLOWER

Entering Wet Bulb Temperature	Total Air Volume	Outdoor Air Temperature Entering Outdoor Coil																			
		85°F					95°F					105°F					115°F				
		Total Cool Cap.	Comp. Motor Input	Sensible To Total Ratio (S/T)			Total Cool Cap.	Comp. Motor Input	Sensible To Total Ratio (S/T)			Total Cool Cap.	Comp. Motor Input	Sensible To Total Ratio (S/T)			Total Cool Cap.	Comp. Motor Input	Sensible To Total Ratio (S/T)		
				Dry Bulb					Dry Bulb					Dry Bulb					Dry Bulb		
cfm	kBtuh	kW	75°F	80°F	85°F	kBtuh	kW	75°F	80°F	85°F	kBtuh	kW	75°F	80°F	85°F	kBtuh	kW	75°F	80°F	85°F	
63°F	3200	118.9	7.05	0.68	0.84	1.00	112.1	7.96	0.69	0.86	1.00	104.6	9.00	0.71	0.89	1.00	96.6	10.17	0.72	0.93	1.00
	4000	124.9	7.11	0.74	0.94	1.00	117.7	8.03	0.76	0.97	1.00	110.0	9.05	0.78	1.00	1.00	102.2	10.23	0.80	1.00	1.00
	4800	129.9	7.17	0.80	1.00	1.00	123.0	8.08	0.83	1.00	1.00	115.7	9.12	0.86	1.00	1.00	108.0	10.30	0.90	1.00	1.00
67°F	3200	126.5	7.12	0.53	0.66	0.80	119.2	8.03	0.53	0.67	0.82	111.4	9.07	0.53	0.68	0.85	103.4	10.25	0.54	0.70	0.89
	4000	132.6	7.19	0.57	0.72	0.90	124.8	8.10	0.57	0.73	0.93	116.7	9.13	0.58	0.75	0.97	108.0	10.30	0.59	0.78	1.00
	4800	137.1	7.25	0.60	0.78	0.99	128.9	8.15	0.61	0.80	1.00	120.2	9.18	0.61	0.83	1.00	111.3	10.34	0.63	0.87	1.00
71°F	3200	134.2	7.21	0.40	0.53	0.64	126.6	8.12	0.39	0.52	0.65	118.5	9.15	0.39	0.52	0.66	110.0	10.32	0.39	0.54	0.68
	4000	140.0	7.28	0.41	0.56	0.70	132.0	8.19	0.41	0.57	0.71	123.5	9.22	0.41	0.57	0.73	114.7	10.38	0.41	0.58	0.76
	4800	144.5	7.34	0.43	0.60	0.76	136.2	8.24	0.43	0.61	0.78	127.2	9.27	0.43	0.61	0.81	117.9	10.43	0.42	0.63	0.84

RATINGS

NOTE – For Temperatures and Capacities not shown in tables, see bulletin – Cooling Unit Rating Table Correction Factor Data in Miscellaneous Engineering Data section.

12.5 TON STANDARD EFFICIENCY KGA150S4M (1ST STAGE) - SINGLE ZONE VAV SUPPLY FAN SUPPLY AIR BLOWER

Entering Wet Bulb Temperature	Total Air Volume	Outdoor Air Temperature Entering Outdoor Coil																			
		65°F					75°F					85°F					95°F				
		Total Cool Cap.	Comp. Motor Input	Sensible To Total Ratio (S/T) Dry Bulb			Total Cool Cap.	Comp. Motor Input	Sensible To Total Ratio (S/T) Dry Bulb			Total Cool Cap.	Comp. Motor Input	Sensible To Total Ratio (S/T) Dry Bulb			Total Cool Cap.	Comp. Motor Input	Sensible To Total Ratio (S/T) Dry Bulb		
				75°F	80°F	85°F			75°F	80°F	85°F			75°F	80°F	85°F			75°F	80°F	85°F
		cfm	kBtuh	kW	75°F	80°F	85°F	kBtuh	kW	75°F	80°F	85°F	kBtuh	kW	75°F	80°F	85°F	kBtuh	kW	75°F	80°F
63°F	2560	68.1	3.12	0.63	0.73	0.83	63.3	3.50	0.62	0.73	0.84	58.5	3.93	0.61	0.73	0.85	53.3	4.42	0.60	0.74	0.87
	3200	74.0	3.15	0.66	0.78	0.90	69.0	3.54	0.66	0.79	0.91	63.6	3.97	0.66	0.79	0.93	58.1	4.46	0.65	0.80	0.96
	3840	78.3	3.18	0.69	0.83	0.95	73.0	3.57	0.69	0.83	0.97	67.4	4.00	0.70	0.85	1.00	61.5	4.49	0.70	0.87	1.00
67°F	2560	73.4	3.15	0.50	0.60	0.70	68.7	3.53	0.49	0.59	0.70	63.6	3.97	0.48	0.59	0.70	58.2	4.46	0.46	0.59	0.71
	3200	79.4	3.19	0.53	0.64	0.75	74.2	3.58	0.52	0.64	0.75	68.8	4.01	0.51	0.64	0.76	62.9	4.50	0.49	0.63	0.77
	3840	83.9	3.22	0.55	0.67	0.79	78.4	3.61	0.54	0.67	0.80	72.6	4.04	0.54	0.68	0.82	66.5	4.53	0.53	0.68	0.84
71°F	2560	79.2	3.19	0.40	0.49	0.58	74.2	3.58	0.38	0.48	0.57	69.0	4.01	0.36	0.47	0.57	63.4	4.50	0.34	0.45	0.57
	3200	85.1	3.22	0.41	0.52	0.62	79.8	3.62	0.39	0.51	0.62	74.2	4.06	0.38	0.50	0.62	68.2	4.55	0.36	0.49	0.61
	3840	89.5	3.26	0.42	0.54	0.65	83.6	3.65	0.41	0.53	0.65	77.7	4.09	0.40	0.53	0.66	71.4	4.58	0.38	0.52	0.66

12.5 TON STANDARD EFFICIENCY KGA150S4M (2ND STAGE) - SINGLE ZONE VAV SUPPLY FAN SUPPLY AIR BLOWER

Entering Wet Bulb Temperature	Total Air Volume	Outdoor Air Temperature Entering Outdoor Coil																			
		85°F					95°F					105°F					115°F				
		Total Cool Cap.	Comp. Motor Input	Sensible To Total Ratio (S/T) Dry Bulb			Total Cool Cap.	Comp. Motor Input	Sensible To Total Ratio (S/T) Dry Bulb			Total Cool Cap.	Comp. Motor Input	Sensible To Total Ratio (S/T) Dry Bulb			Total Cool Cap.	Comp. Motor Input	Sensible To Total Ratio (S/T) Dry Bulb		
				75°F	80°F	85°F			75°F	80°F	85°F			75°F	80°F	85°F			75°F	80°F	85°F
		cfm	kBtuh	kW	75°F	80°F	85°F	kBtuh	kW	75°F	80°F	85°F	kBtuh	kW	75°F	80°F	85°F	kBtuh	kW	75°F	80°F
63°F	3800	139.7	8.40	0.69	0.85	1.00	127.4	9.42	0.70	0.87	1.00	114.8	10.59	0.71	0.90	1.00	101.5	11.94	0.72	0.94	1.00
	4400	145.4	8.45	0.73	0.90	1.00	132.9	9.47	0.74	0.93	1.00	119.8	10.64	0.76	0.97	1.00	106.2	11.99	0.79	1.00	1.00
	5000	150.3	8.49	0.77	0.96	1.00	137.4	9.52	0.79	0.99	1.00	124.4	10.69	0.81	1.00	1.00	111.7	12.05	0.84	1.00	1.00
67°F	3800	150.3	8.49	0.53	0.67	0.82	137.9	9.52	0.53	0.68	0.84	124.7	10.69	0.52	0.69	0.86	111.1	12.04	0.51	0.71	0.90
	4400	156.2	8.55	0.56	0.71	0.87	143.3	9.57	0.55	0.72	0.89	129.7	10.75	0.55	0.74	0.93	115.4	12.10	0.55	0.76	0.97
	5000	161.1	8.59	0.58	0.75	0.92	147.6	9.62	0.58	0.77	0.95	133.7	10.79	0.59	0.79	0.99	119.1	12.14	0.59	0.82	1.00
71°F	3800	161.9	8.60	0.39	0.53	0.66	148.7	9.63	0.38	0.52	0.66	135.1	10.80	0.36	0.52	0.67	120.8	12.15	0.34	0.51	0.68
	4400	167.4	8.65	0.41	0.55	0.69	153.9	9.68	0.39	0.55	0.70	139.8	10.85	0.38	0.54	0.72	124.9	12.20	0.36	0.55	0.74
	5000	171.9	8.70	0.42	0.57	0.73	158.0	9.73	0.41	0.58	0.75	143.5	10.90	0.39	0.58	0.77	128.5	12.24	0.37	0.59	0.80

BLOWER DATA

092S AND 102S STANDARD EFFICIENCY BELT DRIVE BLOWER – BASE UNIT

BLOWER TABLE INCLUDES RESISTANCE FOR BASE UNIT ONLY (NO HEAT SECTION) WITH DRY INDOOR COIL AND AIR FILTERS IN PLACE. FOR ALL UNITS ADD:

- 1 – Wet indoor coil air resistance of selected unit.
- 2 – Any factory installed options air resistance (heat section, economizer, etc.)
- 3 – Any field installed accessories air resistance (duct resistance, diffuser, etc.)

Then determine from blower table blower motor output required.

See page 30 for blower motors and drives.

See page 30 for wet coil and option/accessory air resistance data.

MAXIMUM STATIC PRESSURE WITH GAS HEAT - 2.0 in. w.g.

Total Air Volume cfm	Total Static Pressure – in. w.g.																										
	0.2		0.4		0.6		0.8		1.0		1.2		1.4		1.6		1.8		2		2.2		2.4		2.6		
	RPM	BHP	RPM	BHP	RPM	BHP	RPM	BHP	RPM	BHP	RPM	BHP	RPM	BHP	RPM	BHP	RPM	BHP	RPM	BHP	RPM	BHP	RPM	BHP	RPM	BHP	RPM
1750	608	0.05	651	0.03	696	0.06	744	0.22	794	0.60	845	0.95	894	1.24	934	1.38	978	1.47	1047	1.66	1120	1.89	1179	2.15	1230	2.40	
2000	615	0.07	657	0.05	702	0.10	748	0.36	797	0.72	846	1.05	892	1.30	933	1.45	977	1.55	1049	1.75	1124	2.00	1181	2.23	1234	2.47	
2250	624	0.09	664	0.07	707	0.14	753	0.50	800	0.84	847	1.15	892	1.38	934	1.53	979	1.65	1051	1.86	1126	2.12	1183	2.36	1238	2.62	
2500	632	0.11	672	0.09	714	0.29	758	0.64	803	0.97	849	1.26	893	1.48	936	1.63	983	1.75	1052	1.96	1124	2.22	1184	2.49	1241	2.77	
2750	641	0.13	680	0.11	721	0.45	763	0.78	807	1.09	852	1.37	896	1.58	940	1.74	989	1.88	1053	2.08	1121	2.34	1185	2.63	1244	2.93	
3000	651	0.15	689	0.29	728	0.61	770	0.93	812	1.23	856	1.49	901	1.70	947	1.87	996	2.02	1055	2.21	1120	2.47	1186	2.78	1248	3.10	
3250	661	0.17	698	0.46	737	0.78	777	1.09	819	1.38	862	1.63	908	1.84	955	2.01	1004	2.17	1059	2.36	1122	2.62	1189	2.94	1252	3.28	
3500	672	0.36	708	0.65	746	0.95	786	1.25	827	1.53	870	1.78	916	1.99	965	2.17	1013	2.33	1065	2.52	1126	2.79	1193	3.12	1257	3.47	
3750	684	0.56	719	0.85	756	1.14	795	1.43	836	1.70	880	1.95	927	2.16	976	2.34	1023	2.51	1073	2.71	1133	2.98	1198	3.32	1263	3.67	
4000	697	0.78	731	1.05	768	1.34	807	1.62	848	1.89	892	2.13	940	2.34	988	2.53	1034	2.71	1083	2.91	1141	3.19	1205	3.53	1270	3.89	
4250	710	1.00	745	1.27	781	1.55	819	1.83	861	2.09	906	2.33	954	2.55	1001	2.74	1046	2.93	1094	3.14	1151	3.42	1214	3.76	1278	4.12	

BLOWER DATA

092H AND 102H HIGH EFFICIENCY BELT DRIVE BLOWER – BASE UNIT

BLOWER TABLE INCLUDES RESISTANCE FOR BASE UNIT ONLY (NO HEAT SECTION) WITH DRY INDOOR COIL AND AIR FILTERS IN PLACE. FOR ALL UNITS ADD:

- 1 – Wet indoor coil air resistance of selected unit.
- 2 – Any factory installed options air resistance (heat section, economizer, etc.)
- 3 – Any field installed accessories air resistance (duct resistance, diffuser, etc.)

Then determine from blower table blower motor output required.

See page 30 for blower motors and drives.

See page 30 for wet coil and option/accessory air resistance data.

MAXIMUM STATIC PRESSURE WITH GAS HEAT - 2.0 in. w.g.

Total Air Volume cfm	Total Static Pressure – in. w.g.																									
	0.2		0.4		0.6		0.8		1.0		1.2		1.4		1.6		1.8		2.0		2.2		2.4		2.6	
	RPM	BHP	RPM	BHP	RPM	BHP	RPM	BHP	RPM	BHP	RPM	BHP	RPM	BHP	RPM	BHP	RPM	BHP	RPM	BHP	RPM	BHP	RPM	BHP	RPM	BHP
1750	481	0.21	549	0.4	618	0.57	688	0.7	758	0.82	824	0.93	885	1.08	941	1.23	991	1.39	1038	1.54	1082	1.68	1124	1.82	1166	1.95
2000	493	0.29	561	0.47	629	0.64	700	0.77	768	0.9	832	1.02	892	1.17	946	1.33	995	1.49	1041	1.66	1085	1.81	1126	1.97	1167	2.12
2250	507	0.37	574	0.56	643	0.72	712	0.86	779	0.99	842	1.13	900	1.28	953	1.44	1001	1.61	1045	1.78	1088	1.95	1128	2.12	1168	2.3
2500	521	0.46	588	0.64	657	0.81	727	0.95	792	1.09	853	1.24	909	1.4	960	1.57	1007	1.74	1050	1.93	1091	2.11	1130	2.29	1170	2.48
2750	537	0.56	604	0.74	674	0.91	743	1.06	806	1.21	865	1.36	920	1.53	969	1.71	1014	1.89	1055	2.08	1095	2.27	1133	2.47	1172	2.66
3000	554	0.67	622	0.86	692	1.02	760	1.18	822	1.34	878	1.5	931	1.68	979	1.86	1021	2.06	1061	2.26	1099	2.46	1136	2.65	1174	2.85
3250	572	0.78	641	0.98	712	1.15	778	1.32	838	1.49	892	1.66	943	1.84	989	2.03	1030	2.24	1068	2.45	1105	2.65	1141	2.85	1178	3.06
3500	592	0.9	663	1.12	733	1.3	798	1.47	855	1.65	907	1.83	956	2.02	1000	2.22	1039	2.44	1076	2.65	1111	2.86	1146	3.07	1183	3.27
3750	614	1.04	687	1.28	756	1.47	818	1.65	872	1.83	923	2.02	970	2.22	1011	2.43	1049	2.65	1084	2.87	1118	3.09	1152	3.29	1189	3.51
4000	639	1.22	713	1.48	780	1.66	838	1.83	890	2.02	939	2.22	984	2.44	1023	2.66	1059	2.89	1093	3.11	1126	3.33	1160	3.54	1197	3.77
4250	667	1.43	741	1.69	805	1.86	859	2.02	909	2.22	956	2.45	998	2.68	1036	2.92	1070	3.15	1103	3.37	1135	3.59	1169	3.81	1207	4.05

BLOWER DATA

120S STANDARD EFFICIENCY BELT DRIVE BLOWER – BASE UNIT

BLOWER TABLE INCLUDES RESISTANCE FOR BASE UNIT ONLY (NO HEAT SECTION) WITH DRY INDOOR COIL AND AIR FILTERS IN PLACE. FOR ALL UNITS ADD:

- 1 – Wet indoor coil air resistance of selected unit.
- 2 – Any factory installed options air resistance (heat section, economizer, etc.)
- 3 – Any field installed accessories air resistance (duct resistance, diffuser, etc.)

Then determine from blower table blower motor output required.

See page 30 for blower motors and drives.

See page 30 for wet coil and option/accessory air resistance data.

MAXIMUM STATIC PRESSURE WITH GAS HEAT - 2.0 in. w.g.

Total Air Volume cfm	Total Static Pressure – in. w.g.																										
	0.2		0.4		0.6		0.8		1.0		1.2		1.4		1.6		1.8		2		2.2		2.4		2.6		
	RPM	BHP	RPM	BHP	RPM	BHP	RPM	BHP	RPM	BHP	RPM	BHP	RPM	BHP	RPM	BHP	RPM	BHP	RPM	BHP	RPM	BHP	RPM	BHP	RPM	BHP	RPM
2000	593	0.11	636	0.07	682	0.10	731	0.22	784	0.60	840	0.96	898	1.26	948	1.38	996	1.47	1045	1.57	1092	1.71	1140	1.92	1188	2.32	
2250	604	0.15	645	0.11	690	0.15	739	0.39	790	0.74	846	1.08	901	1.34	953	1.48	1002	1.57	1052	1.70	1100	1.86	1149	2.09	1197	2.42	
2500	615	0.19	655	0.15	699	0.20	747	0.55	797	0.89	851	1.20	906	1.44	959	1.58	1009	1.68	1059	1.83	1108	2.01	1158	2.26	1206	2.52	
2750	626	0.23	666	0.19	709	0.37	755	0.71	805	1.03	858	1.32	912	1.55	966	1.70	1017	1.81	1067	1.97	1117	2.17	1166	2.44	1215	2.71	
3000	637	0.27	677	0.24	719	0.55	764	0.87	813	1.18	866	1.45	920	1.67	975	1.82	1026	1.96	1076	2.13	1126	2.35	1176	2.63	1225	2.92	
3250	650	0.31	688	0.43	730	0.73	775	1.04	823	1.34	875	1.60	930	1.81	985	1.97	1036	2.12	1086	2.31	1136	2.54	1186	2.83	1235	3.13	
3500	663	0.35	700	0.63	741	0.92	786	1.22	834	1.50	886	1.76	942	1.96	997	2.14	1048	2.31	1097	2.51	1147	2.75	1196	3.04	1245	3.35	
3750	676	0.57	714	0.84	754	1.12	798	1.41	846	1.68	899	1.93	956	2.14	1010	2.32	1060	2.51	1109	2.72	1158	2.98	1207	3.27	1255	3.58	
4000	691	0.79	728	1.05	768	1.33	812	1.61	860	1.88	914	2.12	971	2.34	1023	2.53	1072	2.73	1121	2.95	1169	3.22	1218	3.51	1266	3.83	
4250	706	1.03	743	1.28	783	1.55	827	1.82	876	2.09	931	2.33	987	2.55	1037	2.76	1085	2.97	1133	3.20	1181	3.47	1229	3.76	1277	4.08	
4500	722	1.27	759	1.52	799	1.78	844	2.05	894	2.31	949	2.56	1003	2.79	1052	3.00	1098	3.22	1145	3.46	1193	3.73	1241	4.03	1289	4.34	
4750	739	1.53	776	1.77	817	2.03	862	2.30	913	2.56	968	2.81	1020	3.04	1066	3.27	1112	3.49	1158	3.74	1205	4.01	1253	4.30	1301	4.61	
5000	757	1.79	794	2.04	835	2.30	882	2.56	934	2.83	988	3.08	1036	3.32	1081	3.55	1125	3.78	1171	4.02	1218	4.29	1265	4.59	1312	4.89	

BLOWER DATA

120H HIGH EFFICIENCY AND 150S STANDARD EFFICIENCY BELT DRIVE BLOWER – BASE UNIT

BLOWER TABLE INCLUDES RESISTANCE FOR BASE UNIT ONLY (NO HEAT SECTION) WITH DRY INDOOR COIL AND AIR FILTERS IN PLACE. FOR ALL UNITS ADD:

- 1 – Wet indoor coil air resistance of selected unit.
- 2 – Any factory installed options air resistance (heat section, economizer, etc.)
- 3 – Any field installed accessories air resistance (duct resistance, diffuser, etc.)

Then determine from blower table blower motor output required.

See page 30 for blower motors and drives.

See page 30 for wet coil and option/accessory air resistance data.

MAXIMUM STATIC PRESSURE WITH GAS HEAT - 2.0 in. w.g.

Total Air Volume cfm	Total Static Pressure – in. w.g.																										
	0.2		0.4		0.6		0.8		1.0		1.2		1.4		1.6		1.8		2.0		2.2		2.4		2.6		
	RPM	BHP	RPM	BHP	RPM	BHP	RPM	BHP	RPM	BHP	RPM	BHP	RPM	BHP	RPM	BHP	RPM	BHP	RPM	BHP	RPM	BHP	RPM	BHP	RPM	BHP	RPM
2000	497	0.25	558	0.44	624	0.6	694	0.74	764	0.85	830	0.99	889	1.16	943	1.34	994	1.52	1045	1.71	1096	1.89	1146	2.08	1197	2.27	
2250	511	0.34	573	0.52	638	0.68	708	0.82	776	0.94	839	1.09	896	1.26	948	1.45	998	1.64	1048	1.83	1098	2.01	1149	2.2	1200	2.4	
2500	527	0.44	589	0.62	654	0.78	723	0.91	789	1.05	850	1.21	904	1.39	955	1.58	1003	1.77	1052	1.96	1101	2.14	1152	2.33	1203	2.53	
2750	545	0.55	606	0.72	672	0.88	740	1.03	804	1.17	861	1.34	914	1.53	962	1.72	1010	1.92	1057	2.10	1105	2.29	1154	2.47	1206	2.68	
3000	564	0.66	626	0.84	692	1.01	759	1.16	819	1.32	874	1.49	924	1.68	971	1.88	1017	2.08	1063	2.26	1110	2.44	1158	2.63	1208	2.83	
3250	585	0.79	648	0.98	714	1.14	778	1.31	836	1.48	887	1.66	935	1.86	981	2.06	1026	2.26	1071	2.45	1117	2.63	1163	2.80	1213	3.00	
3500	607	0.93	672	1.13	737	1.31	798	1.48	852	1.66	901	1.85	948	2.05	993	2.26	1037	2.46	1081	2.65	1125	2.83	1171	3.01	1221	3.21	
3750	632	1.10	698	1.31	762	1.50	819	1.67	869	1.86	915	2.05	961	2.25	1005	2.47	1049	2.68	1092	2.88	1136	3.05	1181	3.24	1231	3.45	
4000	660	1.30	726	1.52	787	1.70	838	1.87	885	2.06	930	2.26	974	2.48	1018	2.71	1062	2.93	1105	3.12	1149	3.30	1194	3.49	1245	3.72	
4250	691	1.53	755	1.75	810	1.91	857	2.07	901	2.27	945	2.50	990	2.74	1034	2.98	1077	3.20	1120	3.39	1163	3.58	1210	3.79	1262	4.03	
4500	724	1.78	783	1.98	831	2.12	874	2.28	917	2.50	962	2.75	1006	3.02	1051	3.27	1094	3.49	1137	3.70	1181	3.89	1228	4.11	1281	4.38	
4750	757	2.05	809	2.20	851	2.33	891	2.51	935	2.76	980	3.05	1025	3.33	1070	3.59	1113	3.82	1156	4.03	1201	4.24	1249	4.47	1303	4.75	
5000	787	2.31	831	2.43	870	2.57	910	2.78	954	3.06	1000	3.38	1046	3.68	1091	3.95	1135	4.19	1178	4.40	1224	4.62	1272	4.86	1325	5.13	
5250	814	2.55	852	2.66	889	2.83	930	3.09	975	3.41	1023	3.76	1070	4.08	1115	4.35	1159	4.59	1203	4.81	1248	5.03	1297	5.27	1350	5.53	
5500	835	2.78	871	2.91	909	3.13	952	3.44	999	3.81	1049	4.18	1096	4.51	1142	4.79	1186	5.03	1229	5.24	1275	5.46	1324	5.69	---	---	
5750	854	3.01	890	3.19	930	3.48	977	3.86	1027	4.27	1078	4.66	1126	4.99	1171	5.26	1214	5.49	1258	5.70	---	---	---	---	---	---	
6000	871	3.26	910	3.53	955	3.90	1006	4.34	1060	4.80	1111	5.19	1158	5.51	---	---	---	---	---	---	---	---	---	---	---	---	
6250	890	3.57	934	3.94	985	4.41	1041	4.91	1096	5.38	---	---	---	---	---	---	---	---	---	---	---	---	---	---	---	---	

BLOWER DATA

FACTORY INSTALLED BELT DRIVE KIT SPECIFICATIONS

Nominal hp	Maximum hp	Drive Kit Number	RPM Range
2	2.3	1	590 - 890
2	2.3	2	800 - 1105
2	2.3	3	795 - 1195
3	3.45	4	730 - 970
3	3.45	5	940 - 1200
3	3.45	6	1015 - 1300
5	5.75	10	900 - 1135
5	5.75	11	1040 - 1315
5	5.75	12	1125 - 1425

NOTE - Using total air volume and system static pressure requirements determine from blower performance tables rpm and motor output required. Maximum usable output of motors furnished are shown. In Canada, nominal motor output is also maximum usable motor output. If motors of comparable output are used, be sure to keep within the service factor limitations outlined on the motor nameplate.

NOTE - Units equipped with Single Zone VAV Supply Fan option are limited to a motor service factor of 1.0.

POWER EXHAUST FAN PERFORMANCE

Return Air System Static Pressure	Air Volume Exhausted
in. w.g.	cfm
0	3175
0.05	2955
0.10	2685
0.15	2410
0.20	2165
0.25	1920
0.30	1420
0.35	1200

FACTORY INSTALLED OPTIONS/FIELD INSTALLED ACCESSORY AIR RESISTANCE - in. w.g.

Air Volume cfm	Wet Indoor Coil		Gas Heat Exchanger			Economizer	Filters	
	092, 102	120, 150	Standard Heat	Medium Heat	High Heat		MERV 8	MERV 13
1750	0.04	0.04	0.06	0.02	0.02	0.05	0.01	0.03
2000	0.05	0.05	0.07	0.05	0.06	0.06	0.01	0.03
2250	0.06	0.06	0.07	0.07	0.08	0.08	0.01	0.04
2500	0.07	0.07	0.09	0.10	0.11	0.11	0.01	0.05
2750	0.08	0.08	0.09	0.11	0.12	0.12	0.02	0.05
3000	0.10	0.09	0.11	0.12	0.13	0.13	0.02	0.06
3250	0.11	0.10	0.12	0.15	0.16	0.15	0.02	0.06
3500	0.12	0.11	0.12	0.16	0.17	0.15	0.03	0.07
3750	0.14	0.13	0.14	0.19	0.20	0.15	0.03	0.08
4000	0.15	0.14	0.14	0.21	0.22	0.19	0.04	0.08
4250	0.17	0.15	0.14	0.24	0.28	0.19	0.04	0.09
4500	0.19	0.17	0.15	0.26	0.32	0.22	0.04	0.09
4750	0.20	0.18	0.16	0.29	0.37	0.25	0.05	0.10
5000	0.22	0.20	0.16	0.34	0.43	0.29	0.06	0.10
5250	0.24	0.22	0.16	0.37	0.47	0.32	0.06	0.11
5500	0.25	0.23	0.18	0.44	0.54	0.34	0.07	0.12
5750	0.27	0.25	0.19	0.49	0.59	0.45	0.07	0.12
6000	0.29	0.27	0.20	0.54	0.64	0.52	0.08	0.13

BLOWER DATA

CEILING DIFFUSERS AIR RESISTANCE - in. w.g.

Unit Size	RTD11 Step-Down Diffuser			FD11 Flush Diffuser	
	Air Volume cfm	2 Ends Open	1 Side, 2 Ends Open		All Ends & Sides Open
092 Models	2400	0.21	0.18	0.15	0.14
	2600	0.24	0.21	0.18	0.17
	2800	0.27	0.24	0.21	0.20
	3000	0.32	0.29	0.25	0.25
	3200	0.41	0.37	0.32	0.31
	3400	0.50	0.45	0.39	0.37
	3600	0.61	0.54	0.48	0.44
102 & 120 Models	3800	0.73	0.63	0.57	0.51
	3600	0.36	0.28	0.23	0.15
	3800	0.40	0.32	0.26	0.18
	4000	0.44	0.36	0.29	0.21
	4200	0.49	0.40	0.33	0.24
	4400	0.54	0.44	0.37	0.27
	4600	0.60	0.49	0.42	0.31
	4800	0.65	0.53	0.46	0.35
150 Models	5000	0.69	0.58	0.50	0.39
	5200	0.75	0.62	0.54	0.43
	4200	0.22	0.19	0.16	0.10
	4400	0.28	0.24	0.20	0.12
	4600	0.34	0.29	0.24	0.15
	4800	0.40	0.34	0.29	0.19
	5000	0.46	0.39	0.34	0.23
	5200	0.52	0.44	0.39	0.27
	5400	0.58	0.49	0.43	0.31
5600	0.64	0.54	0.47	0.35	
5800	0.70	0.59	0.51	0.39	

CEILING DIFFUSER AIR THROW DATA

Model No.	Air Volume cfm	¹ Effective Throw Range	
		RTD11 Step-Down	FD11 Flush
		ft.	ft.
092 Models	2600	24 - 29	19 - 24
	2800	25 - 30	20 - 28
	3000	27 - 33	21 - 29
	3200	28 - 35	22 - 29
	3400	30 - 37	22 - 30
102, 120 Models	3600	25 - 33	22 - 29
	3800	27 - 35	22 - 30
	4000	29 - 37	24 - 33
	4200	32 - 40	26 - 35
	4400	34 - 42	28 - 37
150 Models	5600	39 - 49	28 - 37
	5800	42 - 51	29 - 38
	6000	44 - 54	40 - 50
	6200	45 - 55	42 - 51
	6400	46 - 55	43 - 52
6600	47 - 56	45 - 56	

¹ Throw is the horizontal or vertical distance an air stream travels on leaving the outlet or diffuser before the maximum velocity is reduced to 50 ft. per minute. Four sides open.

ELECTRICAL DATA**7.5 TON****7.5 TON STANDARD EFFICIENCY (R-410A)****KGA092S4**

¹ Voltage - 60hz		208/230V - 3 Ph			460V - 3 Ph			575V - 3 Ph		
Compressor 1	Rated Load Amps	13.1			6.1			4.4		
	Locked Rotor Amps	83.1			41			33		
Compressor 2	Rated Load Amps	13.1			6.1			4.4		
	Locked Rotor Amps	83.1			41			33		
Outdoor Fan Motors (2)	Full Load Amps	2.4			1.3			1		
	(total)	(4.8)			(2.6)			(2)		
Power Exhaust (1) 0.33 HP	Full Load Amps	2.4			1.3			1		
Service Outlet 115V GFI (amps)		15			15			20		
Indoor Blower Motor	Horsepower	2	3	5	2	3	5	2	3	5
	Full Load Amps	7.5	10.6	16.7	3.4	4.8	7.6	2.7	3.9	6.1
² Maximum Overcurrent Protection	Unit Only	50	50	60	25	25	30	15	20	20
	With (1) 0.33 HP Power Exhaust	50	60	70	25	25	30	20	20	25
³ Minimum Circuit Ampacity	Unit Only	42	45	52	20	22	25	15	16	19
	With (1) 0.33 HP Power Exhaust	45	48	55	22	23	26	16	17	20

NOTE - All units have a minimum Short Circuit Current Rating (SCCR) of 5000 amps.

¹ Extremes of operating range are plus and minus 10% of line voltage.² HACR type breaker or fuse.³ Refer to National or Canadian Electrical Code manual to determine wire, fuse and disconnect size requirements.**7.5 TON HIGH EFFICIENCY (R-410A)****KGA092H4**

¹ Voltage - 60hz		208/230V - 3 Ph			460V - 3 Ph			575V - 3 Ph		
Compressor 1	Rated Load Amps	13.1			6.1			4.4		
	Locked Rotor Amps	83.1			41			33		
Compressor 2	Rated Load Amps	13.1			6.1			4.4		
	Locked Rotor Amps	83.1			41			33		
Outdoor Fan Motors (2)	Full Load Amps	2.4			1.3			1		
	(total)	(4.8)			(2.6)			(2)		
Power Exhaust (1) 0.33 HP	Full Load Amps	2.4			1.3			1		
Service Outlet 115V GFI (amps)		15			15			20		
Indoor Blower Motor	Horsepower	2	3	5	2	3	5	2	3	5
	Full Load Amps	7.5	10.6	16.7	3.4	4.8	7.6	2.7	3.9	6.1
² Maximum Overcurrent Protection	Unit Only	50	50	60	25	25	30	15	20	20
	With (1) 0.33 HP Power Exhaust	50	60	70	25	25	30	20	20	25
³ Minimum Circuit Ampacity	Unit Only	42	45	52	20	22	25	15	16	19
	With (1) 0.33 HP Power Exhaust	45	48	55	22	23	26	16	17	20

NOTE - All units have a minimum Short Circuit Current Rating (SCCR) of 5000 amps.

¹ Extremes of operating range are plus and minus 10% of line voltage.² HACR type breaker or fuse.³ Refer to National or Canadian Electrical Code manual to determine wire, fuse and disconnect size requirements.

ELECTRICAL DATA**8.5 TON****8.5 TON STANDARD EFFICIENCY (R-410A)****KGA102S4**

¹ Voltage - 60hz		208/230V - 3 Ph			460V - 3 Ph			575V - 3 Ph		
Compressor 1	Rated Load Amps	14.5			6.3			6		
	Locked Rotor Amps	98			55			41		
Compressor 2	Rated Load Amps	14.5			6.3			6		
	Locked Rotor Amps	98			55			41		
Outdoor Fan Motors (2)	Full Load Amps	2.4			1.3			1		
	(total)	(4.8)			(2.6)			(2)		
Power Exhaust (1) 0.33 HP	Full Load Amps	2.4			1.3			1		
Service Outlet 115V GFI (amps)		15			15			20		
Indoor Blower Motor	Horsepower	2	3	5	2	3	5	2	3	5
	Full Load Amps	7.5	10.6	16.7	3.4	4.8	7.6	2.7	3.9	6.1
² Maximum Overcurrent Protection	Unit Only	50	60	70	25	25	30	20	25	25
	With (1) 0.33 HP Power Exhaust	60	60	70	25	25	30	25	25	25
³ Minimum Circuit Ampacity	Unit Only	45	49	55	21	22	25	19	20	22
	With (1) 0.33 HP Power Exhaust	48	51	58	22	23	27	20	21	23

NOTE - All units have a minimum Short Circuit Current Rating (SCCR) of 5000 amps.

¹ Extremes of operating range are plus and minus 10% of line voltage.² HACR type breaker or fuse.³ Refer to National or Canadian Electrical Code manual to determine wire, fuse and disconnect size requirements.**8.5 TON HIGH EFFICIENCY (R-410A)****KGA102H4**

¹ Voltage - 60hz		208/230V - 3 Ph			460V - 3 Ph			575V - 3 Ph		
Compressor 1	Rated Load Amps	13.7			6.2			4.8		
	Locked Rotor Amps	83.1			41			33		
Compressor 2	Rated Load Amps	13.7			6.2			4.8		
	Locked Rotor Amps	83.1			41			33		
Outdoor Fan Motors (2)	Full Load Amps	2.4			1.3			1		
	(total)	(4.8)			(2.6)			(2)		
Power Exhaust (1) 0.33 HP	Full Load Amps	2.4			1.3			1		
Service Outlet 115V GFI (amps)		15			15			20		
Indoor Blower Motor	Horsepower	2	3	5	2	3	5	2	3	5
	Full Load Amps	7.5	10.6	16.7	3.4	4.8	7.6	2.7	3.9	6.1
² Maximum Overcurrent Protection	Unit Only	50	50	60	25	25	30	20	20	25
	With (1) 0.33 HP Power Exhaust	50	60	70	25	25	30	20	20	25
³ Minimum Circuit Ampacity	Unit Only	44	47	54	20	22	25	16	17	20
	With (1) 0.33 HP Power Exhaust	46	49	56	22	23	26	17	18	21

NOTE - All units have a minimum Short Circuit Current Rating (SCCR) of 5000 amps.

¹ Extremes of operating range are plus and minus 10% of line voltage.² HACR type breaker or fuse.³ Refer to National or Canadian Electrical Code manual to determine wire, fuse and disconnect size requirements.

ELECTRICAL DATA**10 TON****10 TON STANDARD EFFICIENCY (R-410A)****KGA120S4**

¹ Voltage - 60hz		208/230V - 3 Ph			460V - 3 Ph			575V - 3 Ph		
Compressor 1	Rated Load Amps	13.5			8			5		
	Locked Rotor Amps	109			59			40		
Compressor 2	Rated Load Amps	13.5			8			5		
	Locked Rotor Amps	109			59			40		
Outdoor Fan Motors (2)	Full Load Amps	2.4			1.3			1		
	(total)	(4.8)			(2.6)			(2)		
Power Exhaust (1) 0.33 HP	Full Load Amps	2.4			1.3			1		
Service Outlet 115V GFI (amps)		15			15			20		
Indoor Blower Motor	Horsepower	2	3	5	2	3	5	2	3	5
	Full Load Amps	7.5	10.6	16.7	3.4	4.8	7.6	2.7	3.9	6.1
² Maximum Overcurrent Protection	Unit Only	50	50	60	30	30	35	20	20	25
	With (1) 0.33 HP Power Exhaust	50	60	70	30	30	35	20	20	25
³ Minimum Circuit Ampacity	Unit Only	43	46	53	24	26	29	16	18	20
	With (1) 0.33 HP Power Exhaust	46	49	56	26	27	30	17	19	21

NOTE - All units have a minimum Short Circuit Current Rating (SCCR) of 5000 amps.

¹ Extremes of operating range are plus and minus 10% of line voltage.² HACR type breaker or fuse.³ Refer to National or Canadian Electrical Code manual to determine wire, fuse and disconnect size requirements.**10 TON HIGH EFFICIENCY (R-410A)****KGA120H4**

¹ Voltage - 60hz		208/230V - 3 Ph			460V - 3 Ph			575V - 3 Ph		
Compressor 1	Rated Load Amps	13.5			8			5		
	Locked Rotor Amps	109			59			40		
Compressor 2	Rated Load Amps	13.5			8			5		
	Locked Rotor Amps	109			59			40		
Outdoor Fan Motors (2)	Full Load Amps	2.4			1.3			1		
	(total)	(4.8)			(2.6)			(2)		
Power Exhaust (1) 0.33 HP	Full Load Amps	2.4			1.3			1		
Service Outlet 115V GFI (amps)		15			15			20		
Indoor Blower Motor	Horsepower	2	3	5	2	3	5	2	3	5
	Full Load Amps	7.5	10.6	16.7	3.4	4.8	7.6	2.7	3.9	6.1
² Maximum Overcurrent Protection	Unit Only	50	50	60	30	30	35	20	20	25
	With (1) 0.33 HP Power Exhaust	50	60	70	30	30	35	20	20	25
³ Minimum Circuit Ampacity	Unit Only	43	46	53	24	26	29	16	18	20
	With (1) 0.33 HP Power Exhaust	46	49	56	26	27	30	17	19	21

NOTE - All units have a minimum Short Circuit Current Rating (SCCR) of 5000 amps.

¹ Extremes of operating range are plus and minus 10% of line voltage.² HACR type breaker or fuse.³ Refer to National or Canadian Electrical Code manual to determine wire, fuse and disconnect size requirements.

ELECTRICAL DATA

12.5 TON STANDARD EFFICIENCY (R-410A)

KGA150S4

¹ Voltage - 60hz		208/230V - 3 Ph			460V - 3 Ph			575V - 3 Ph		
Compressor 1	Rated Load Amps	19.6			8.2			6.6		
	Locked Rotor Amps	136			66.1			55.3		
Compressor 2	Rated Load Amps	19.6			8.2			6.6		
	Locked Rotor Amps	136			66.1			55.3		
Outdoor Fan Motors (2)	Full Load Amps	3			1.5			1.2		
	(total)	(6)			(3)			(2.4)		
Power Exhaust (1) 0.33 HP	Full Load Amps	2.4			1.3			1		
Service Outlet 115V GFI (amps)		15			15			20		
Indoor Blower Motor	Horsepower	2	3	5	2	3	5	2	3	5
	Full Load Amps	7.5	10.6	16.7	3.4	4.8	7.6	2.7	3.9	6.1
² Maximum Overcurrent Protection	Unit Only	70	80	80	30	30	35	25	25	25
	With (1) 0.33 HP Power Exhaust	70	80	80	30	35	35	25	25	30
³ Minimum Circuit Ampacity	Unit Only	58	61	67	25	27	30	20	22	24
	With (1) 0.33 HP Power Exhaust	60	64	70	27	28	31	21	23	25

NOTE - All units have a minimum Short Circuit Current Rating (SCCR) of 5000 amps.

¹ Extremes of operating range are plus and minus 10% of line voltage.

² HACR type breaker or fuse.

³ Refer to National or Canadian Electrical Code manual to determine wire, fuse and disconnect size requirements.

UNIT CLEARANCES - INCHES (MM)

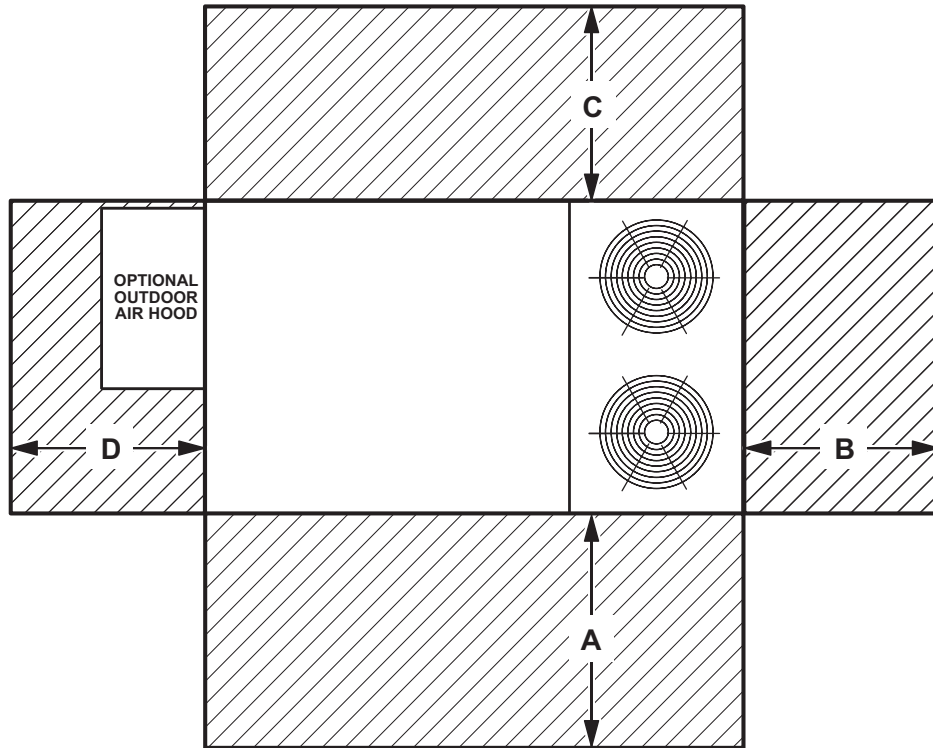

¹ Unit Clearance	A		B		C		D		Top Clearance
	in.	mm	in.	mm	in.	mm	in.	mm	
Service Clearance	60	1524	36	914	36	914	60	1524	Unobstructed
Clearance to Combustibles	36	914	1	25	1	25	1	25	
Minimum Operation Clearance	36	914	36	914	36	914	36	914	

NOTE - Entire perimeter of unit base requires support when elevated above the mounting surface.

¹ Service Clearance - Required for removal of serviceable parts.

Clearance to Combustibles - Required for clearance to combustible material.

Minimum Operation Clearance - Required clearance for proper unit operation.

OUTDOOR SOUND DATA

Unit Model Number	Octave Band Linear Sound Power Levels dB, re 10 ⁻¹² Watts - Center Frequency - Hz							1 Sound Rating Number (SRN) (dBA)
	125	250	500	1000	2000	4000	8000	
092, 102 and 120	76	79	84	83	79	73	66	88
150	77	80	85	84	79	74	66	88

Note - The octave sound power data does not include tonal corrections.

¹ Sound Rating Number according to ARI Standard 270-95 or ARI Standard 370-2001 (includes pure tone penalty). "SRN" is the overall A-Weighted Sound Power Level, (LWA), dB (100 Hz to 10,000 Hz).

WEIGHT DATA

Model Number	Net		Shipping		Model Number	Net		Shipping	
	lbs.	kg	lbs.	kg		lbs.	kg	lbs.	kg
092S Base Unit	918	416	1003	455	092H Base Unit	1100	499	1185	538
092S Max. Unit	1069	485	1154	523	092H Max. Unit	1251	567	1336	606
102S Base Unit	938	425	1023	464	102H Base Unit	1107	502	1192	541
102S Max. Unit	1089	494	1174	533	102H Max. Unit	1258	571	1343	609
120S Base Unit	986	447	1071	486	120H Base Unit	1142	518	1227	557
120S Max. Unit	1137	516	1222	554	120H Max. Unit	1293	586	1378	625
150S Base Unit	1072	486	1157	525					
150S Max. Unit	1223	555	1308	593					

OPTIONS / ACCESSORIES

Model Number	Shipping Weight	
	lbs.	kg

ECONOMIZER / OUTDOOR AIR / EXHAUST

Economizer

Economizer Dampers	60	27
Barometric Relief Dampers (downflow)	8	4
Barometric Relief Damper Hood (downflow)	25	11
Outdoor Air Hood (downflow)	23	10

Outdoor Air Dampers

Outdoor Air Damper Section (downflow) - Automatic	9	4
Outdoor Air Damper Section (downflow) - Manual	2	1
Outdoor Air Damper Hood (downflow)	9	4

Power Exhaust

	31	14
--	----	----

GAS HEAT EXCHANGER (NET WEIGHT)

Medium Heat (adder over standard heat)	9	4
High Heat (adder over standard heat)	32	15

SINGLE ZONE VAV SUPPLY FAN SUPPLY AIR BLOWER OPTION

Variable Frequency Drive (VFD) and associated components	10	5
--	----	---

ROOF CURBS

Hybrid Roof Curbs, Downflow

8 in. height	60	27
14 in. height	85	39
18 in. height	100	45
24 in. height	125	57

Adjustable Pitch Curb, Downflow

14 in. height	191	82
---------------	-----	----

CEILING DIFFUSERS

Step-Down	RTD11-95	88	40
	RTD11-135	205	93
	RTD11-185	392	178
Flush	FD11-95	75	34
	FD11-135	174	79
	FD11-185	289	131
Transitions	C1DIFF30B-1	30	14
	C1DIFF31B-1	32	15
	C1DIFF32B-1	36	16

PACKAGING

LTL Packaging (less than truck load)	105	48
--------------------------------------	-----	----

DIMENSIONS - UNIT - INCHES (MM)

Model No.	CORNER WEIGHTS												CENTER OF GRAVITY											
	AA				BB				CC				DD				EE				FF			
	Base		Max.		Base		Max.		Base		Max.		Base		Max.		Base		Max.		Base		Max.	
	lbs.	kg	lbs.	kg	lbs.	kg	lbs.	kg	lbs.	kg	lbs.	kg	lbs.	kg	in.	mm	in.	mm	in.	mm	in.	mm	in.	mm
092S	236	107	280	127	201	91	232	105	218	99	248	112	264	120	309	140	44.5	1130	43.5	1105	24.5	622	25.5	648
092H	282	128	328	149	241	109	272	123	261	118	290	131	316	143	361	164	44.5	1130	43.5	1105	24.5	622	25.5	648
102S	241	109	286	130	205	93	237	107	222	101	252	114	270	122	315	143	44.5	1130	43.5	1105	24.5	622	25.5	648
102H	284	129	330	150	242	110	273	124	263	119	291	132	318	144	363	165	44.5	1130	43.5	1105	24.5	622	25.5	648
120S	255	116	301	136	215	97	246	111	231	105	261	118	285	129	330	150	44	1118	43	1092	24.75	629	25.75	654
120H	295	134	342	155	249	113	279	127	268	122	296	134	330	150	375	170	44	1118	43	1092	24.75	629	25.75	654
150S	275	125	321	146	232	105	263	119	253	115	282	128	312	142	358	162	44	1118	43	1092	24	610	25	635

Base Unit - The unit with NO OPTIONS.

Max. Unit - The unit with ALL OPTIONS Installed. (Economizer, etc.)

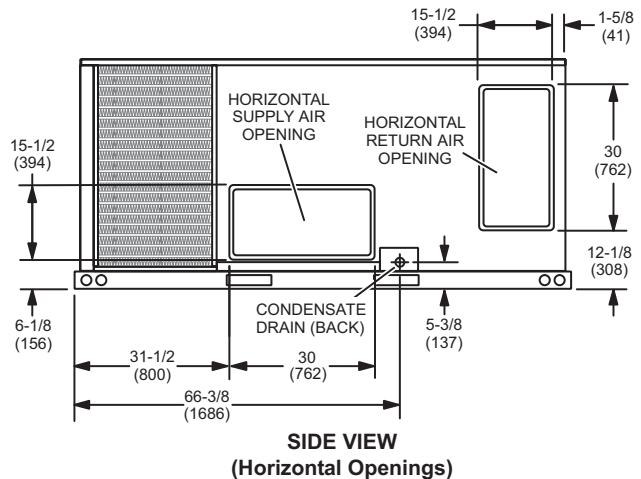
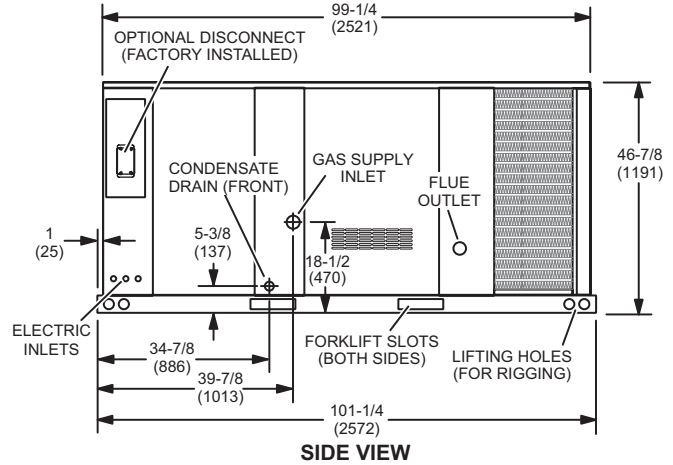
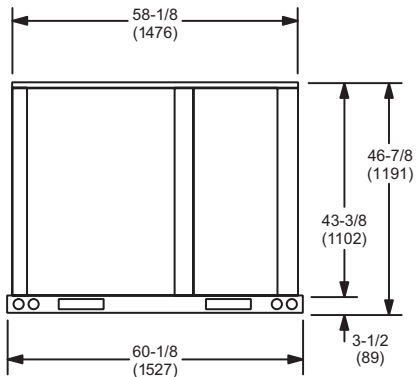
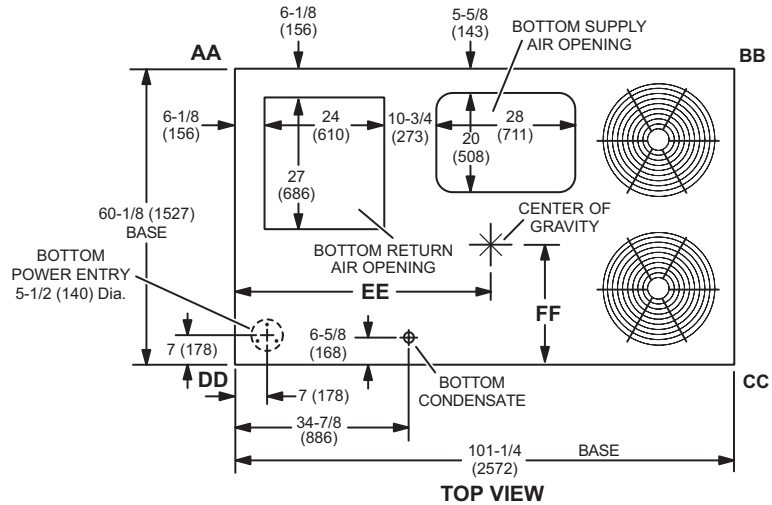

OUTDOOR AIR HOOD DETAIL

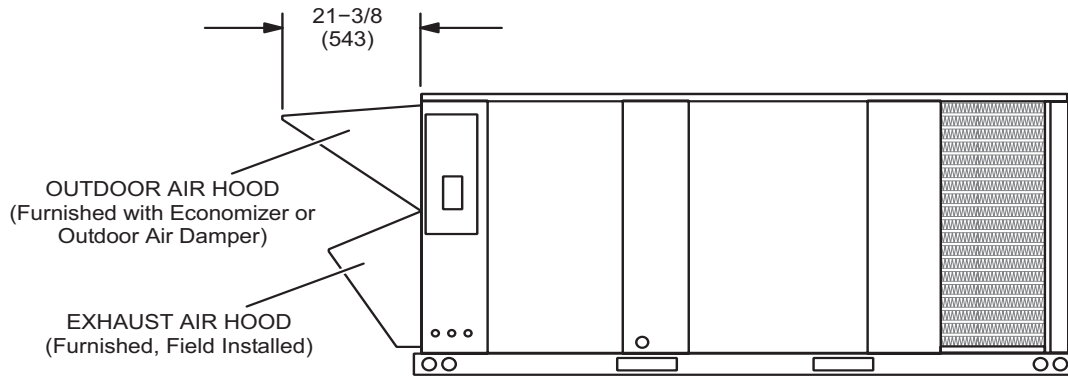

DIMENSIONS - ACCESSORIES - INCHES (MM)

HORIZONTAL ECONOMIZER APPLICATION

(With Furnished Barometric Relief Dampers and Optional Horizontal Discharge Kit - Required)

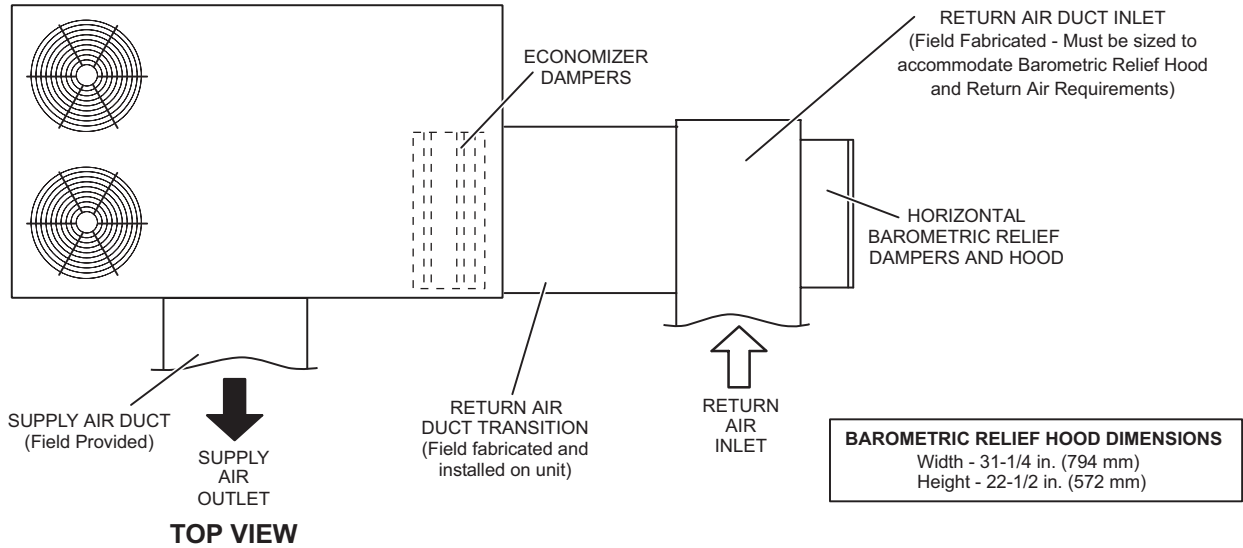

TOP VIEW

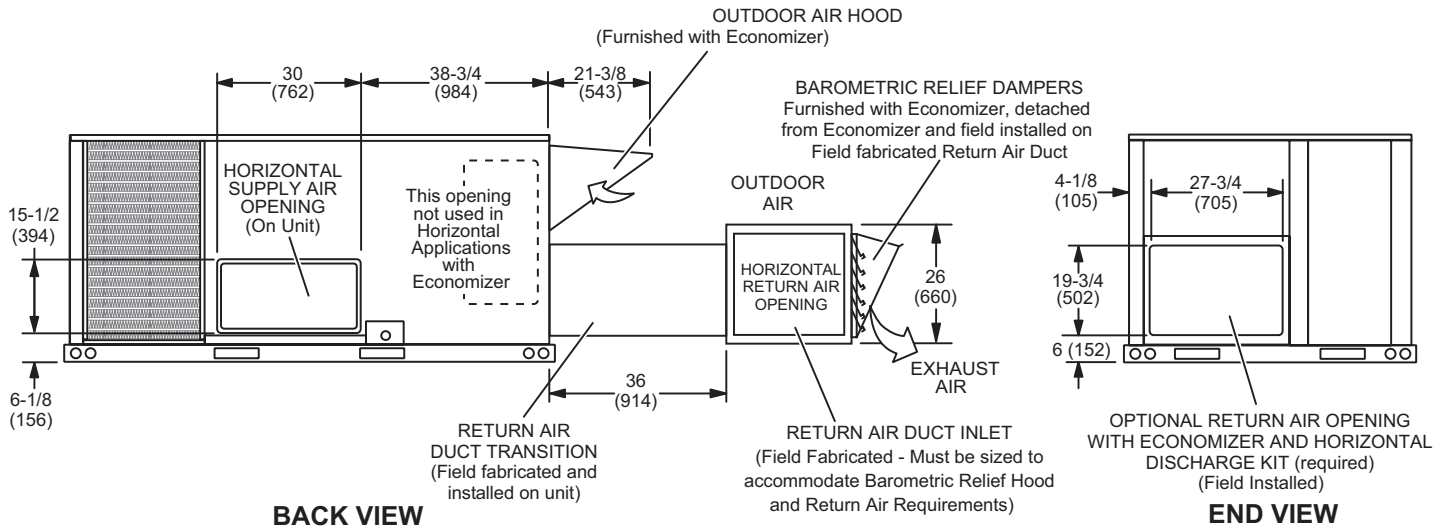

BACK VIEW

END VIEW

NOTE - Return Air Duct and Transition must be supported.

**BAROMETRIC RELIEF DAMPERS
(Furnished with Economizer)**

(Field installed in horizontal return air duct adjacent to unit)

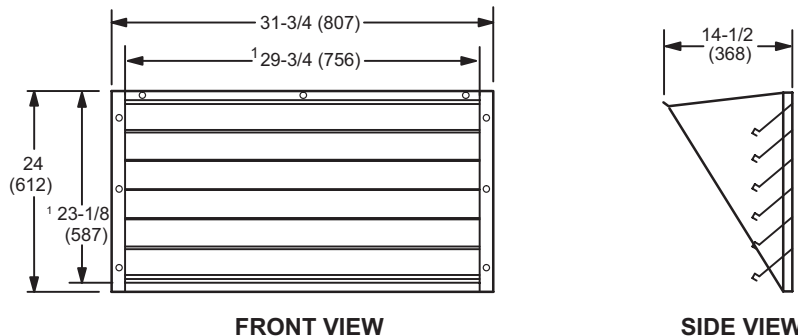

FRONT VIEW

SIDE VIEW

¹ NOTE - Opening size required in return air duct.

DIMENSIONS - ACCESSORIES - INCHES (MM)

HORIZONTAL ECONOMIZER APPLICATION

(with Optional Low Profile Horizontal Barometric Relief Dampers and Horizontal Discharge Kit - Required)

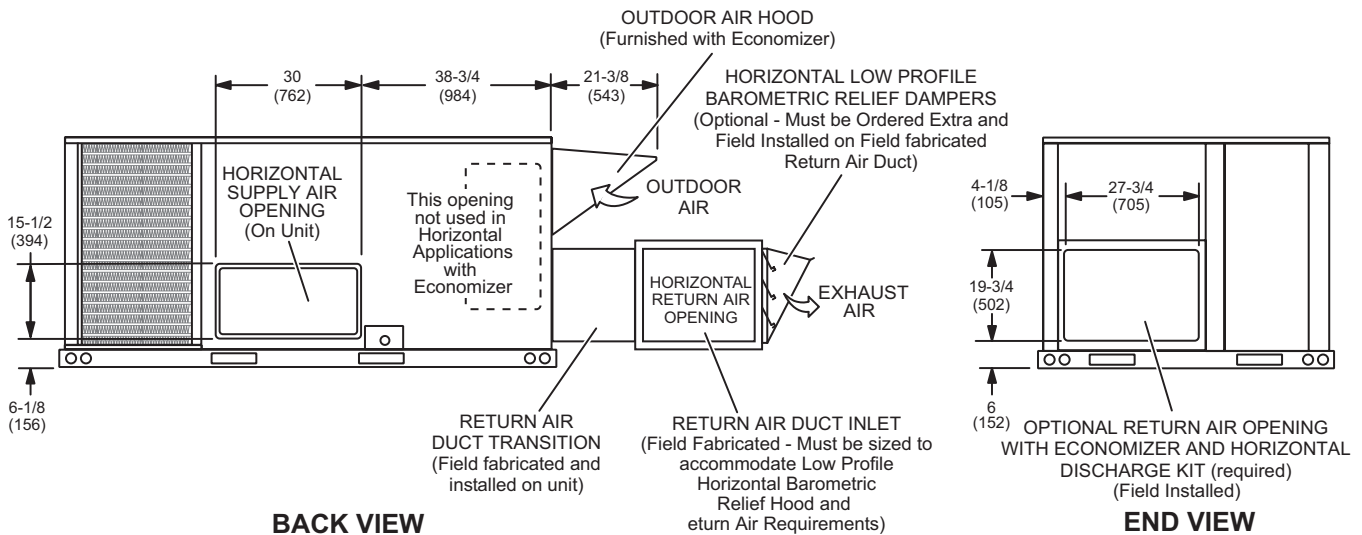
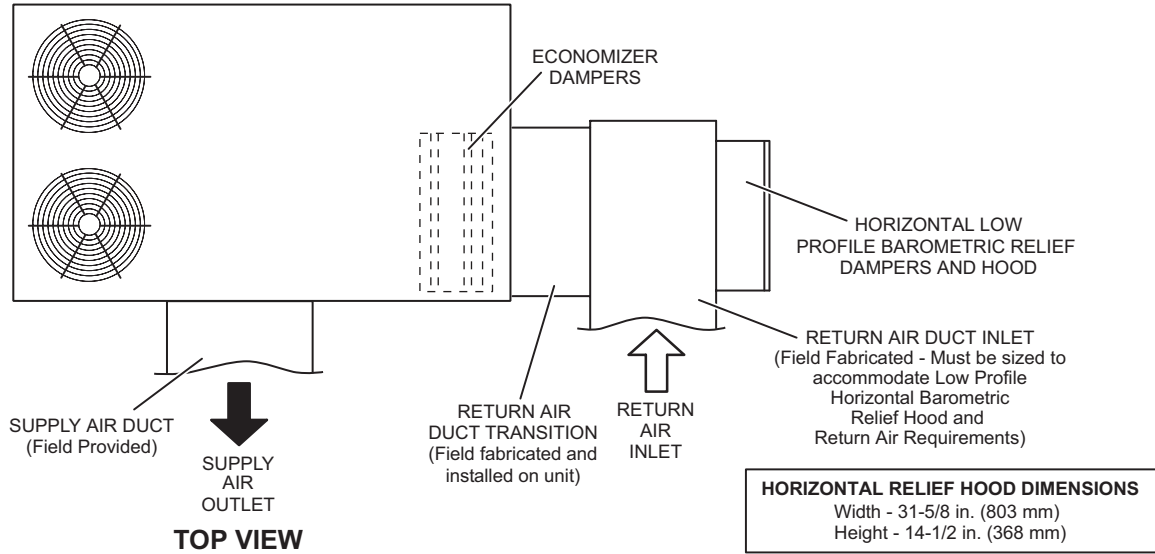

NOTE - Return Air Duct and Transition must be supported.

HORIZONTAL LOW PROFILE BAROMETRIC RELIEF DAMPERS

(Field installed in horizontal return air duct adjacent to unit)

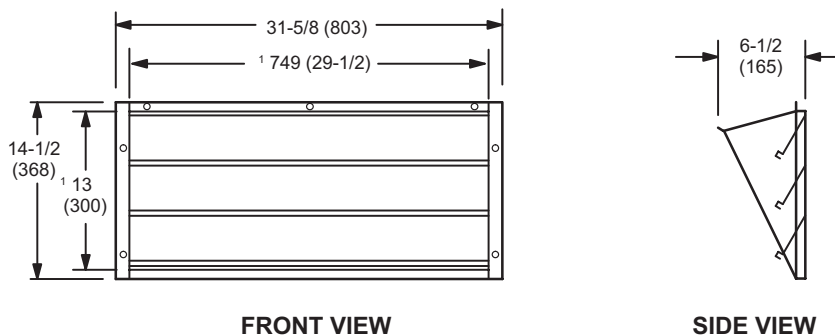

¹ NOTE - Opening size required in return air duct.

DIMENSIONS - ACCESSORIES - INCHES (MM)

HYBRID ROOF CURBS - DOUBLE DUCT OPENING

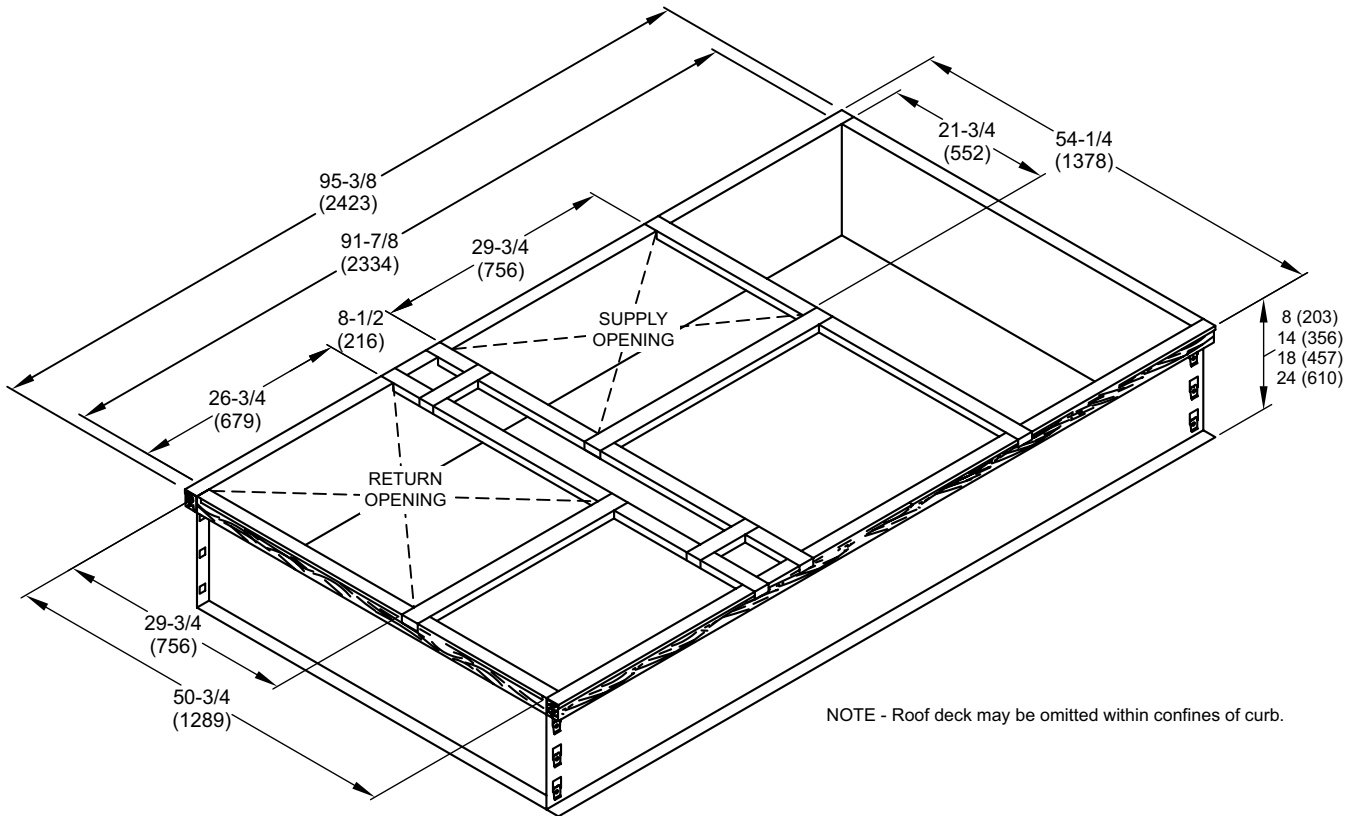

TYPICAL FLASHING DETAIL FOR ROOF CURB

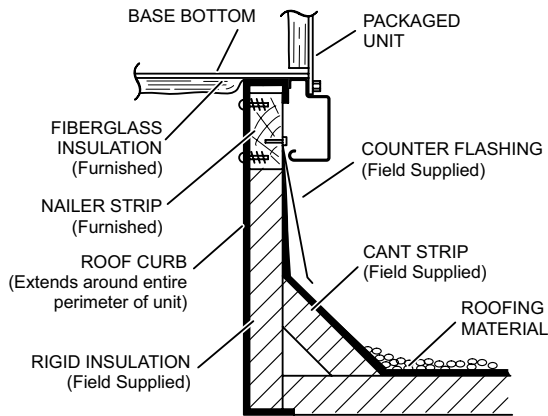

DETAIL ROOF CURB

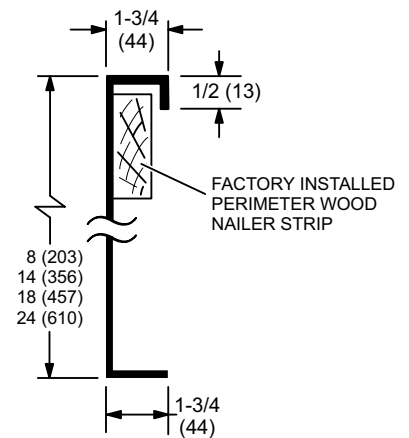

DIMENSIONS - ACCESSORIES - INCHES (MM)

ADJUSTABLE PITCH CURBS - DOUBLE DUCT OPENING

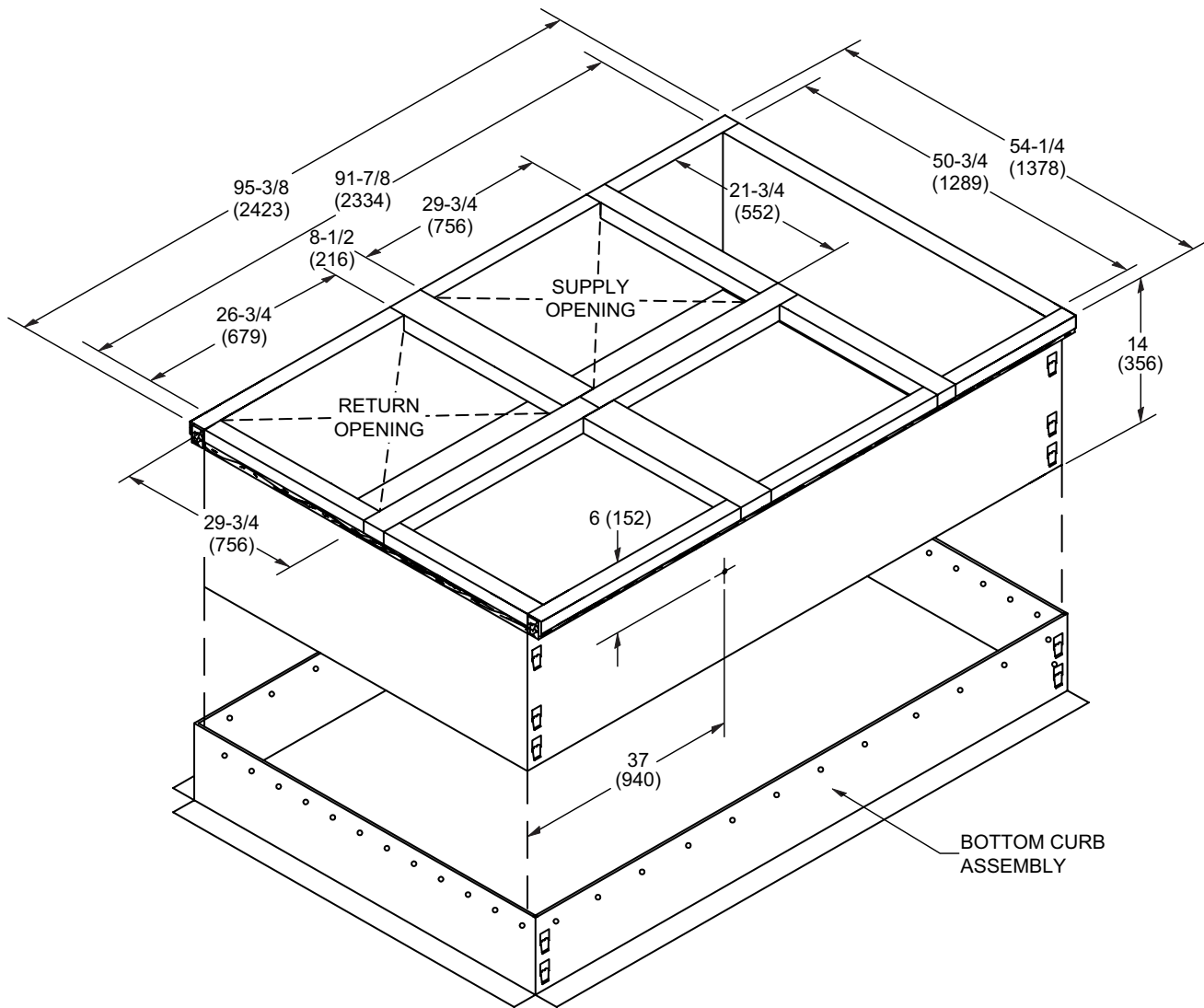

NOTE - Maximum slope pitch is 3/4 in. per 1 foot (19 mm per 305 mm) in any one direction.

TYPICAL FLASHING DETAIL FOR ROOF CURB

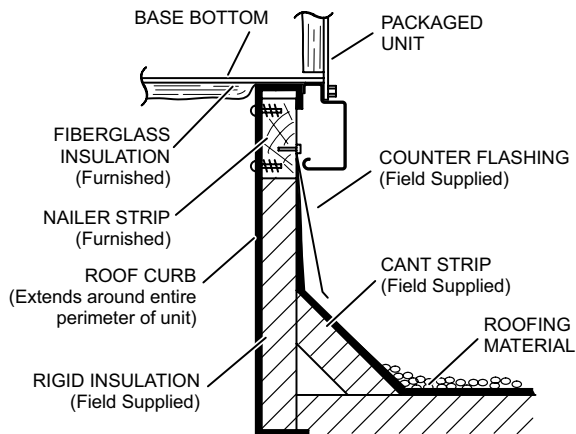

DETAIL ROOF CURB

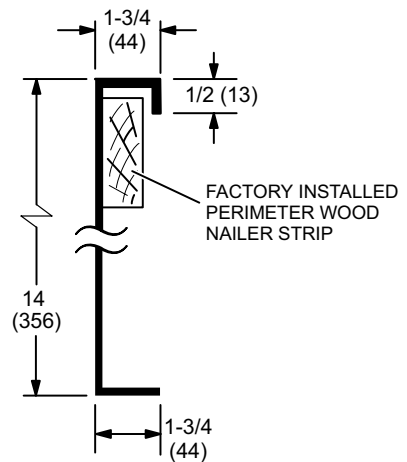

DIMENSIONS - ACCESSORIES - INCHES (MM)

ROOF CURBS WITH SUPPLY & RETURN AIR TRANSITIONS FOR CEILING DIFFUSERS

C1DIFF30B-1 ROUND TRANSITIONS
(for 092 models with FD11-95, RTD11-95 Diffusers)

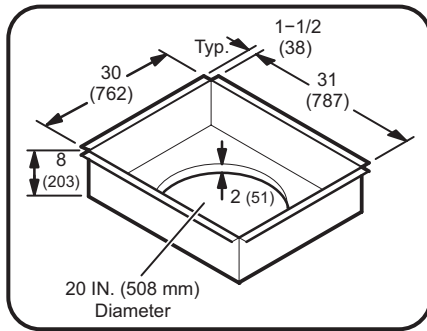

C1DIFF31B-1 & C1DIFF32B-1 RECTANGULAR TRANSITIONS
(for 102 thru 150 models with FD11-135-185, RTD11-135-185 Diffusers)

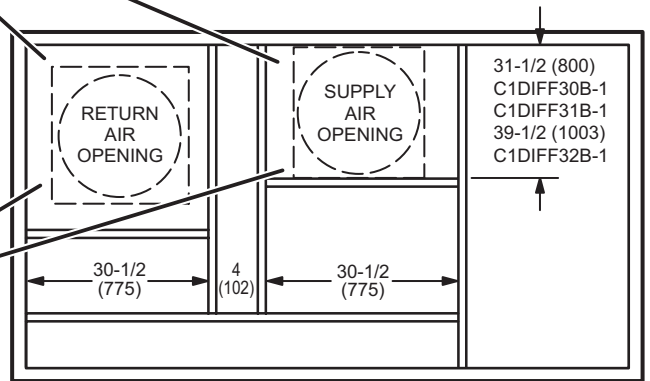
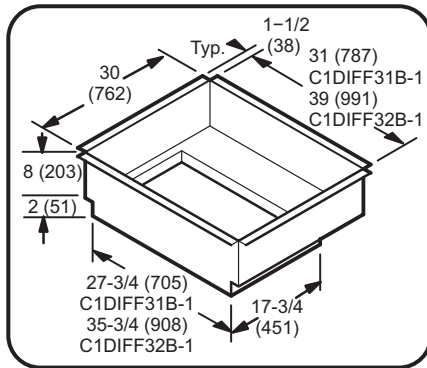

TOP VIEW

DIMENSIONS - ACCESSORIES - INCHES (MM)

COMBINATION CEILING SUPPLY AND RETURN DIFFUSERS

STEP-DOWN CEILING DIFFUSER

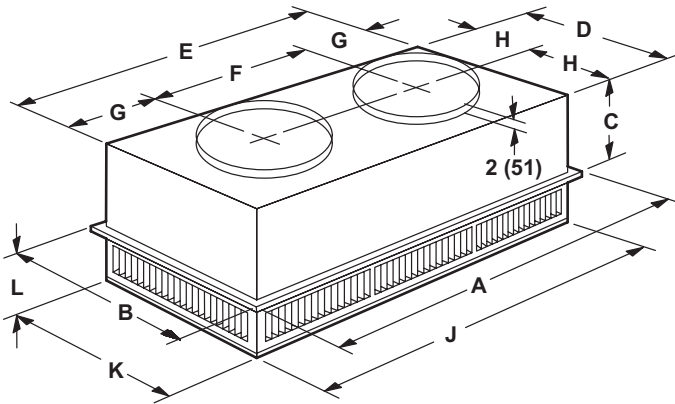

FLUSH CEILING DIFFUSER

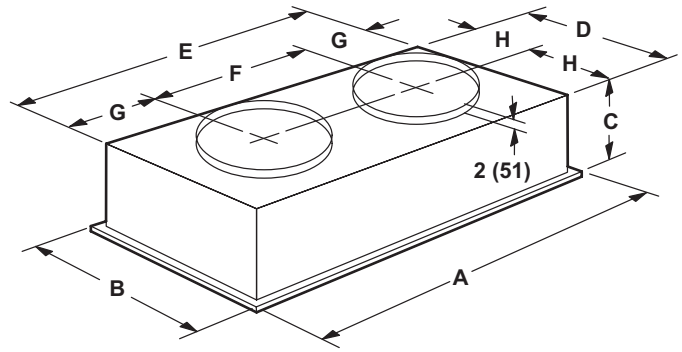

Model Number		RTD11-95
A	in.	47-5/8
	mm	1159
B	in.	29-5/8
	mm	752
C	in.	14-3/8
	mm	365
D	in.	27-1/2
	mm	699
E	in.	45-1/2
	mm	1158
F	in.	22-1/2
	mm	572
G	in.	11-1/2
	mm	292
H	in.	13-3/4
	mm	349
J	in.	45-1/2
	mm	1156
K	in.	27-1/2
	mm	699
L	in.	8-1/8
	mm	206
Duct Size	in.	20 round
	mm	508 round

Model Number		FD11-95
A	in.	47-5/8
	mm	1159
B	in.	29-5/8
	mm	752
C	in.	16-5/8
	mm	422
D	in.	27
	mm	686
E	in.	45
	mm	1143
F	in.	22-1/2
	mm	572
G	in.	11-1/4
	mm	286
H	in.	13-1/2
	mm	343
Duct Size	in.	20 round
	mm	508 round

DIMENSIONS - ACCESSORIES - INCHES (MM)

COMBINATION CEILING SUPPLY AND RETURN DIFFUSERS

STEP-DOWN CEILING DIFFUSER

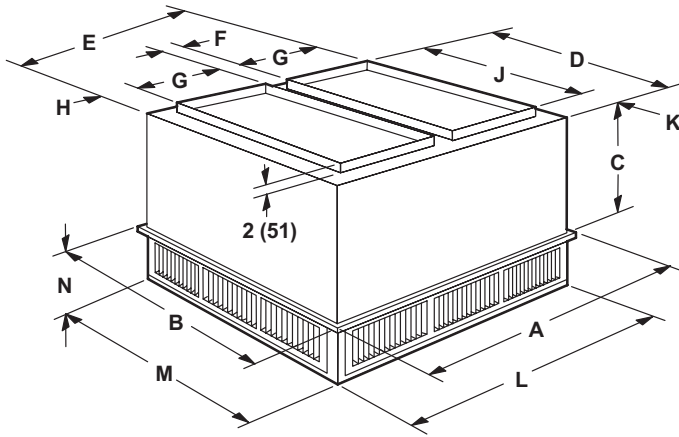

FLUSH CEILING DIFFUSER

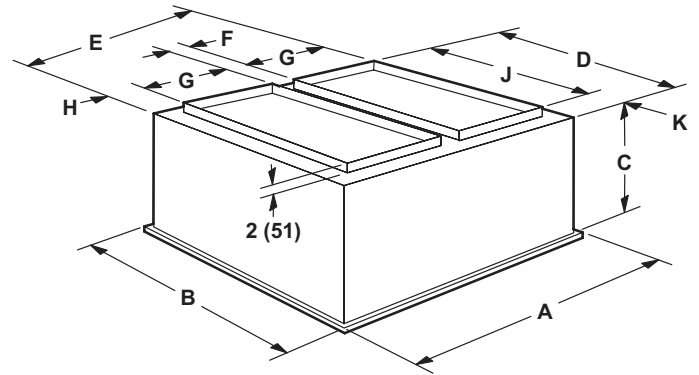

Model Number		RTD11-135	RTD11-185
A	in.	47-5/8	47-5/8
	mm	1210	1210
B	in.	35-5/8	47-5/8
	mm	905	1210
C	in.	20-5/8	24-5/8
	mm	524	625
D	in.	33-1/2	45-1/2
	mm	851	1156
E	in.	45-1/2	45-1/2
	mm	1156	1156
F	in.	4-1/2	4-1/2
	mm	114	114
G	in.	18	18
	mm	457	457
H	in.	2-1/2	2-1/2
	mm	64	64
J	in.	28	36
	mm	711	914
K	in.	2-3/4	4-3/4
	mm	70	121
L	in.	45-1/2	45-1/2
	mm	1156	1156
M	in.	33-1/2	45-1/2
	mm	851	1156
N	in.	9-1/8	10-1/8
	mm	232	257
Duct Size	in.	18 x 28	18 x 36
	mm	457 x 711	457 x 914

Model Number		FD11-135	FD11-185
A	in.	47-5/8	47-5/8
	mm	1210	1210
B	in.	35-5/8	47-5/8
	mm	905	1210
C	in.	23-1/4	29-1/4
	mm	591	743
D	in.	33	45
	mm	838	1143
E	in.	45	45
	mm	1143	1143
F	in.	4-1/2	4-1/2
	mm	114	114
G	in.	18	18
	mm	457	457
H	in.	2-1/4	2-1/4
	mm	57	57
J	in.	28	36
	mm	711	914
K	in.	2-1/2	4-1/2
	mm	64	114
Duct Size	in.	18 x 28	18 x 36
	mm	457 x 711	457 x 914

REVISIONS

Section	Description
Accessory Dimensions	Added drawing for Adjustable Pitch Roof Curb.
Options/Accessories	New Supply and Return Transitions. New Smoke Detectors.
Ratings	Updated for KGA092S4 Models.
Specifications	Refrigerant charge updated for KGA092S4B.



ALLIED™
Commercial

Visit us at www.allied-commercial.com

For the latest technical information, visit us at www.allied-commercial.com

Contact us at 1-800-448-5872

NOTE - Due to Allied Commercial ongoing commitment to quality, Specifications, Ratings and Dimensions subject to change without notice and without incurring liability. Improper installation, adjustment, alteration, service or maintenance can cause property damage or personal injury. Installation and service must be performed by a qualified installer and servicing agency.