

INSTALLATION INSTRUCTIONS

⚠ WARNING

Improper installation, adjustment, alteration, service or maintenance can cause property damage, personal injury or loss of life. Installation and service must be performed by a qualified installer, service agency or the gas supplier

Table Of Contents

Dimensions	Page 2
Parts Arrangements	Page 3
Shipping and Packing List	Page 4
General	Page 4
Safety	Page 4
Unit Support	Page 5
Duct Connection	Page 5
Rigging Unit For Lifting	Page 5
Condensate Drains	Page 6
Connect Gas Piping	Page 8
Pressure Test Gas Piping	Page 9

KGA/KCA092	(7.5 Ton)
KGA/KCA102	(8.5 Ton)
KGA/KCA120	(10 Ton)
KGA/KCA150	(12-1/2 Ton)

GAS AND COOLING PACKAGED UNITS
 506348-01
 10/2009

High Altitude Derate	Page 9
Electrical Connections	Page 9
Unit Power-Up	Page 10
Blower Operation and Adjustments	Page 10
Cooling Start-Up	Page 17
Gas Heat Start-Up	Page 19
Heating Operation and Adjustments	Page 20
Electric Heat Start-Up	Page 21
Service	Page 21

RETAIN THESE INSTRUCTIONS FOR FUTURE REFERENCE

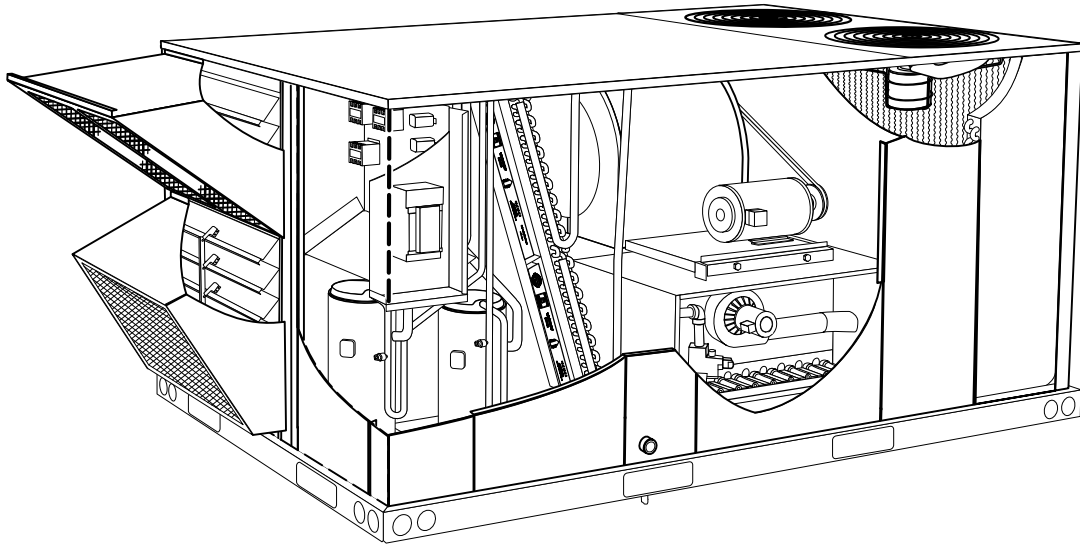

KGA SHOWN



KGA/KCA092, 102, 120, & 150 DIMENSIONS - Gas heat section shown

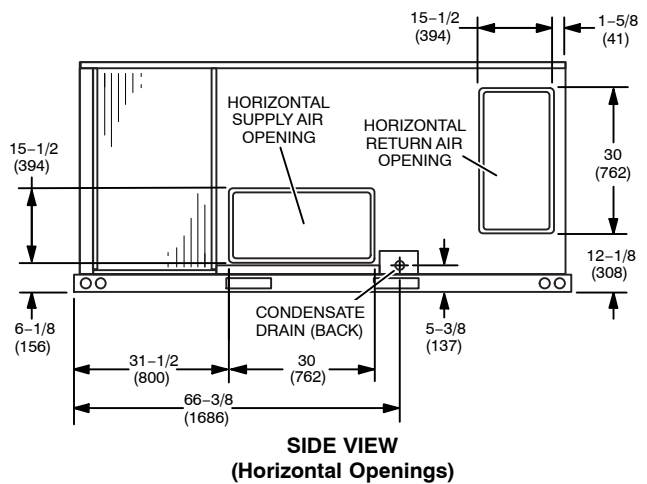
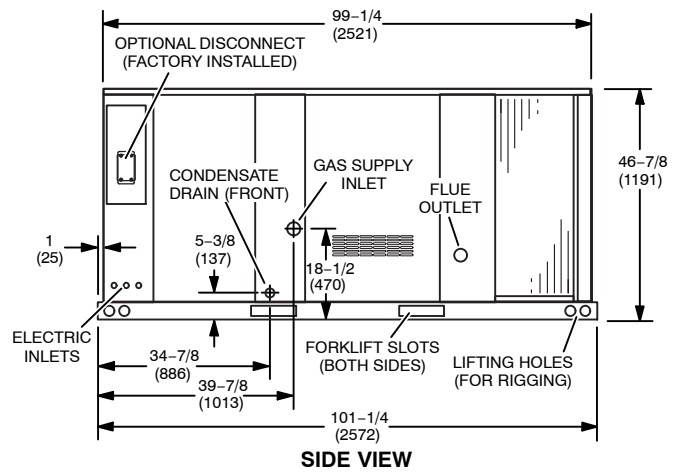
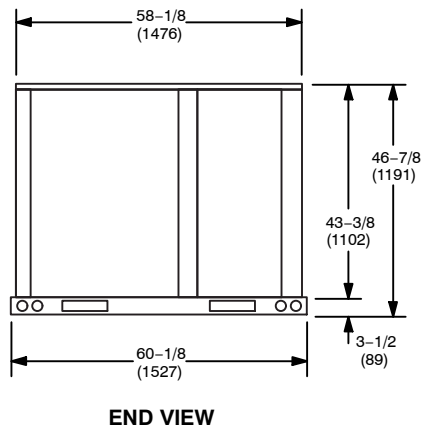
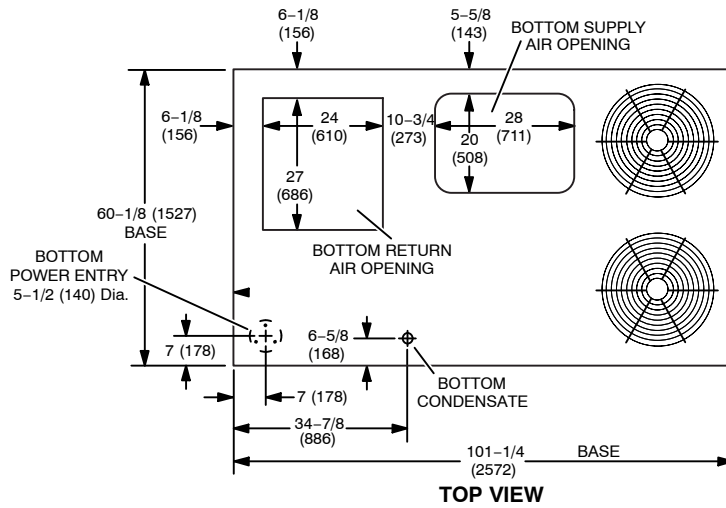

KGA092, 102, 120, & 150 PARTS ARRANGEMENT

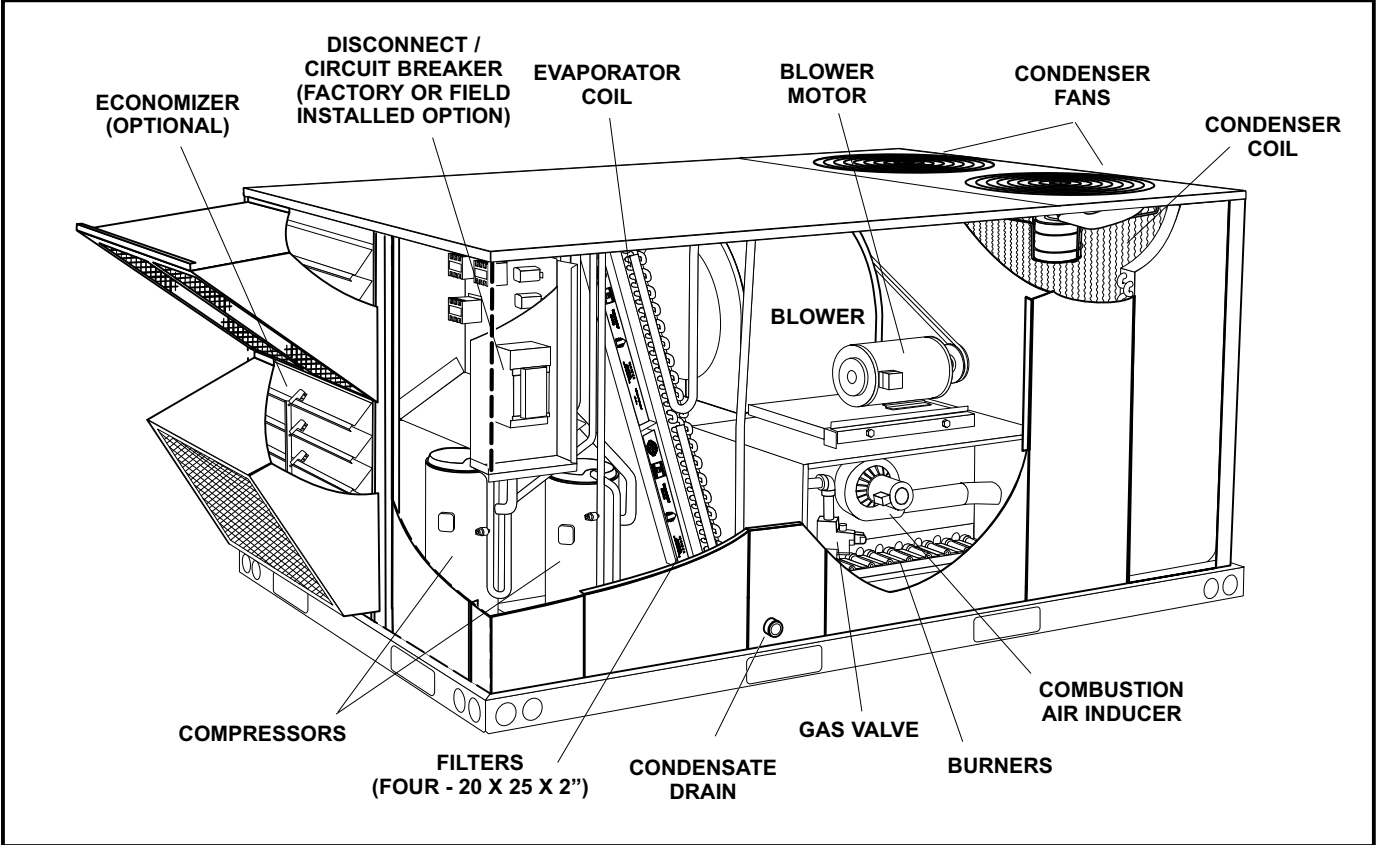

KCA092, 102, 120, & 150 PARTS ARRANGEMENT

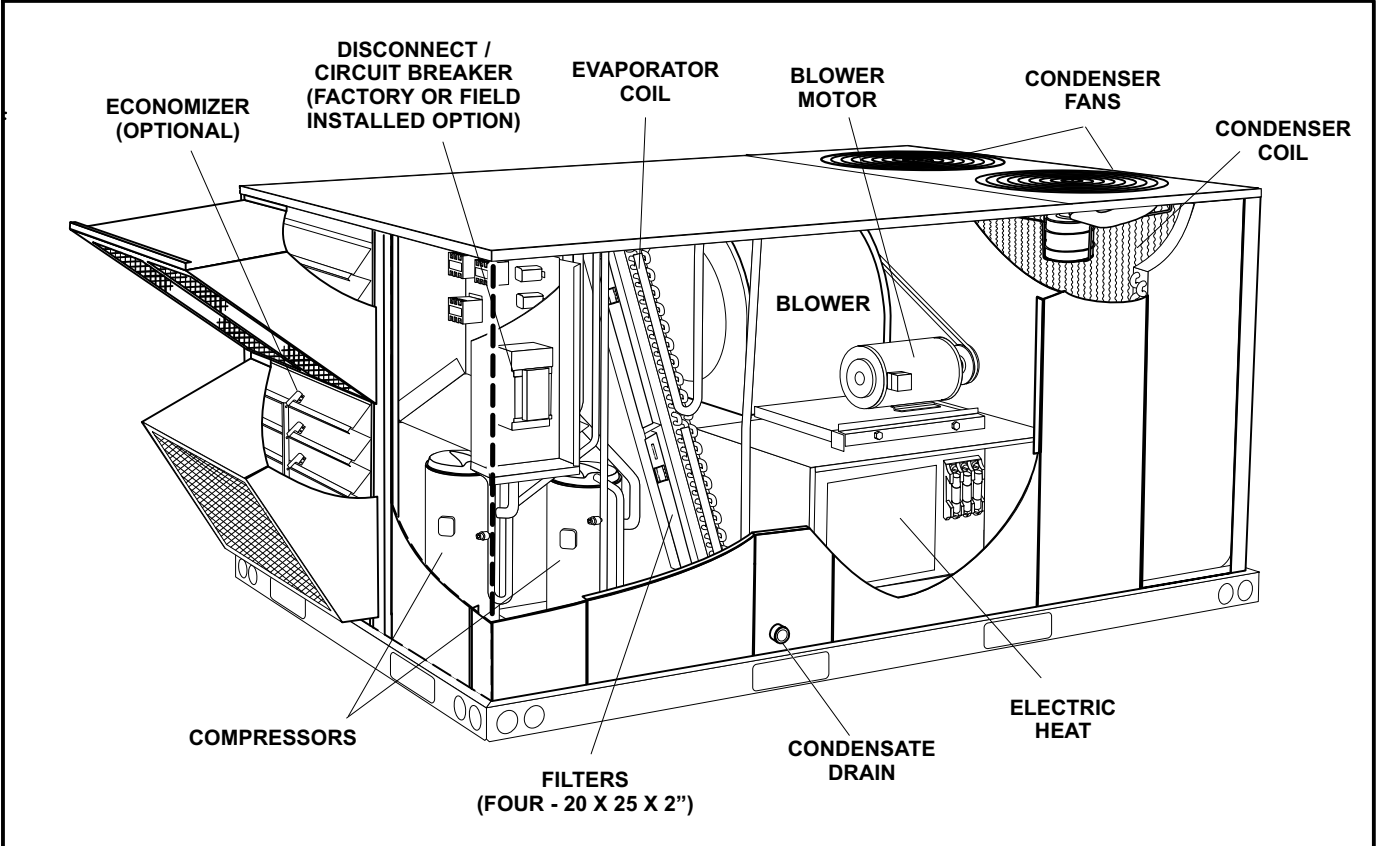

⚠ CAUTION

Danger of sharp metallic edges. Can cause injury. Take care when servicing unit to avoid accidental contact with sharp edges.

Shipping and Packing List

Package 1 of 1 contains:

1- Assembled unit

Check unit for shipping damage. Receiving party should contact last carrier immediately if shipping damage is found.

General

These instructions are intended as a general guide and do not supersede local codes in any way. Authorities having jurisdiction should be consulted before installation.

The KGA units are available in three heating inputs. The KCA cooling packaged rooftop unit is the same basic design as the KGA unit except for the heating section. Optional electric heat is available for KCA units. KGA and KCA units have identical refrigerant circuits with respective 7-1/2, 8-1/2, 10, and 12-1/2 ton cooling capacities.

Availability of units and options varies by brand.

Safety

See figure 1 for unit clearances.

Use of this unit as a construction heater or air conditioner is not recommended during any phase of construction. Very low return air temperatures, harmful vapors and operation of the unit with clogged or misplaced filters will damage the unit.

⚠ IMPORTANT

The Clean Air Act of 1990 bans the intentional venting of refrigerant (CFC's and HCFC's) as of July 1, 1992. Approved methods of recovery, recycling or reclaiming must be followed. Fines and/or incarceration may be levied for non-compliance.

⚠ WARNING



Electric shock hazard and danger of explosion. Can cause injury, death or product or property damage. Turn off gas and electrical power to unit before performing any maintenance or servicing operations on the unit. Follow lighting instructions attached to unit when putting unit back into operation and after service or maintenance.

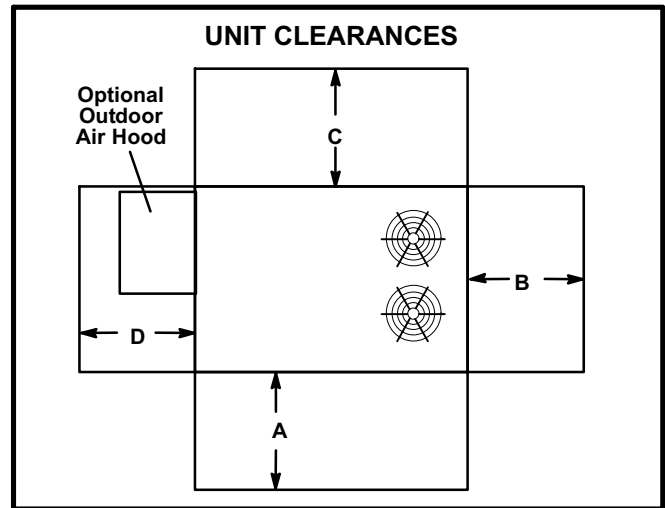

FIGURE 1

¹ Unit Clearance	A in.(mm)	B in.(mm)	C in.(mm)	D in.(mm)	Top Clearance
Service Clearance	60 (1524)	36 (914)	36 (914)	60 (914)	Unob- structed
Clearance to Combustibles	36 (914)	1 (25)	1 (25)	1 (25)	Unob- structed
Minimum Opera- tion Clearance	36 (914)	36 (914)	36 (914)	36 (914)	Unob- structed

Note - Entire perimeter of unit base requires support when elevated above mounting surface.

¹ **Service Clearance** - Required for removal of serviceable parts.

Clearance to Combustibles - Required clearance to combustible material (gas units).

Minimum Operation Clearance - Required clearance for proper unit operation.

⚠ NOTICE

Roof Damage!

This system contains both refrigerant and oil. Some rubber roofing material may absorb oil, causing the rubber to swell. Bubbles in the rubber roofing material can cause leaks. Protect the roof surface to avoid exposure to refrigerant and oil during service and installation. Failure to follow this notice could result in damage to roof surface.

If this unit has been used for heating or cooling of buildings or structures under construction, the following conditions must be met or the warranty will be void:

- A room thermostat must control the unit. The use of fixed jumpers that will provide continuous heating or cooling is not allowed.
- A pre-filter must be installed at the entry to the return air duct.
- The return air duct must be provided and sealed to the unit.
- Return air temperature range between 55°F (13°C) and 80°F (27°C) must be maintained.
- Air filters must be replaced and pre-filters must be removed upon construction completion.

- The input rate and temperature rise must be set per the unit rating plate.
- The heat exchanger, components, duct system, air filters and evaporator coil must be thoroughly cleaned following final construction clean-up.
- The unit operating conditions (including airflow, cooling operation, ignition, input rate, temperature rise and venting) must be verified according to these installation instructions.

Unit Support

In downflow discharge installations, install the unit on a non-combustible surface only. Unit may be installed on combustible surfaces when used in horizontal discharge applications or in downflow discharge applications when installed on an C1CURB roof mounting frame.

NOTE - Securely fasten roof frame to roof per local codes.

A-Downflow Discharge Application

Roof Mounting with C1CURB

Make sure the cap over the unit bottom drain hole is secure.

- 1- The C1CURB roof mounting frame must be installed, flashed and sealed in accordance with the instructions provided with the frame.
- 2- The C1CURB roof mounting frame should be square and level to 1/16" per linear foot (5mm per linear meter) in any direction.
- 3- Duct must be attached to the roof mounting frame and not to the unit; supply and return plenums must be installed before setting the unit.

Installer's Roof Mounting Frame

Many types of roof frames can be used to install the unit depending upon different roof structures. Items to keep in mind when using the building frame or supports are:

- 1- The base is fully enclosed and insulated, so an enclosed frame is not required.
- 2- The frames or supports must be constructed with non-combustible materials and should be square and level to 1/16" per linear foot (5mm per linear meter) in any direction.
- 3- Frame or supports must be high enough to prevent any form of moisture from entering unit. Recommended minimum frame height is 14" (356mm).

- 4- Duct must be attached to the roof mounting frame and not to the unit. Supply and return plenums must be installed before setting the unit.
- 5- Units require support along all four sides of unit base. Supports must be constructed of steel or suitably treated wood materials.

NOTE-When installing a unit on a combustible surface for downflow discharge applications, an C1CURB roof mounting frame is required.

B-Horizontal Discharge Applications

- 1- Units installed in horizontal airflow applications must use a horizontal conversion kit (K1HECK00).
- 2- Specified installation clearances must be maintained when installing units. Refer to figure 1.
- 3- Top of support slab should be approximately 4" (102mm) above the finished grade and located so no run-off water from higher ground can collect around the unit.
- 4- Units require support along all four sides of unit base. Supports must be constructed of steel or suitably treated wood materials.

Duct Connection

All exterior ducts, joints and openings in roof or building walls must be insulated and weather-proofed with flashing and sealing compounds in accordance with applicable codes. Any duct passing through an unconditioned space must be insulated.

⚠ CAUTION

In downflow applications, do not drill or punch holes in base of unit. Leaking in roof may occur if unit base is punctured.

Rigging Unit For Lifting

Rig unit for lifting by attaching four cables to holes in unit base rail. See figure 2.

- 1- Detach wooden base protection before rigging.
- 2- Connect rigging to the unit base using both holes in each corner.
- 3- All panels must be in place for rigging.
- 4- Place field-provided H-style pick in place just above top edge of unit. Frame must be of adequate strength and length. (H-style pick prevents damage to unit.)

RIGGING

UNIT	*WEIGHT	
	LBS.	KG.
KGA	1401	636
KCA	1366	620

CAUTION - Do not walk on unit.

*Maximum weight with all available installed accessories.

LIFTING POINT SHOULD BE DIRECTLY ABOVE CENTER OF GRAVITY

IMPORTANT - ALL PANELS MUST BE IN PLACE FOR RIGGING.

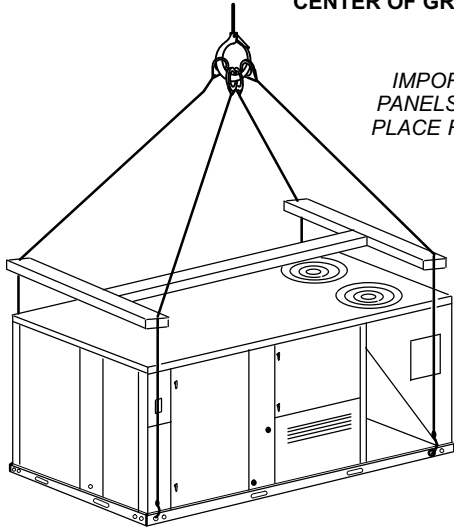

FIGURE 2

Condensate Drains

Make drain connection to the 1" N.P.T. drain coupling provided on unit.

Note - The drain pan is made with a glass reinforced engineered plastic capable of withstanding typical joint torque but can be damaged with excessive force. Tighten pipe nipple hand tight and turn an additional quarter turn.

A trap must be installed between drain connection and an open vent for proper condensate removal. See figure 3 or 4. It is sometimes acceptable to drain condensate onto the roof or grade; however, a tee should be fitted to the trap to direct condensate downward. The condensate line must be vented. Check local codes concerning condensate disposal. Refer to pages 2 and 3 for condensate drain location.

Units are shipped with the drain coupling facing the front of the unit. Condensate can be drained from the back or bottom of the unit with the following modifications. The unit can be installed in either downflow or horizontal air discharge regardless of condensate drain location.

Rear Drain Connection

- 1- Remove heat access door. See figure 5.
- 2- Remove filter access door.

CONDENSATE SIDE DRAIN CONNECTION

CAULK AROUND CONDENSATE COUPLING

NOTE - Allow clearance to open doors when installing condensate piping.

**Minimum Pitch
1" (25 mm) per
10' (3 m) of line**

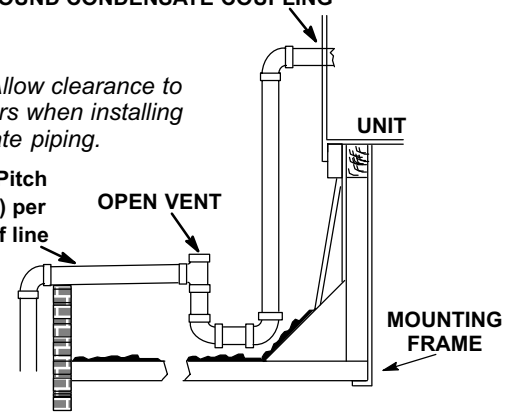

FIGURE 3

CONDENSATE BOTTOM DRAIN CONNECTION

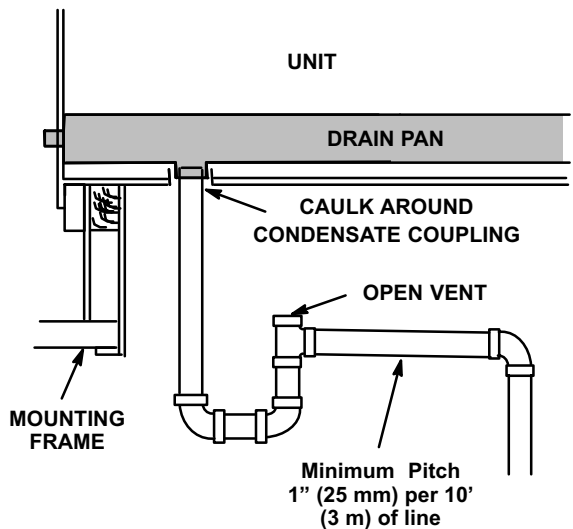

FIGURE 4

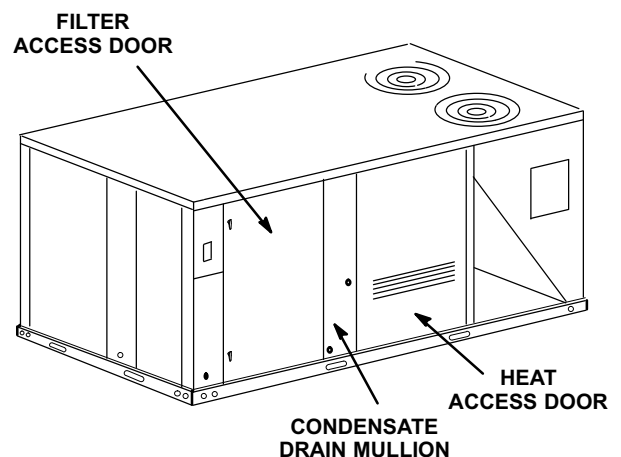

FIGURE 5

- 3- Remove eight screws holding condensate drain mullion and remove mullion.
- 4- Lift front edge of the drain pan (to clear bottom drain plug) and slide drain pan out of unit. See figure 6.

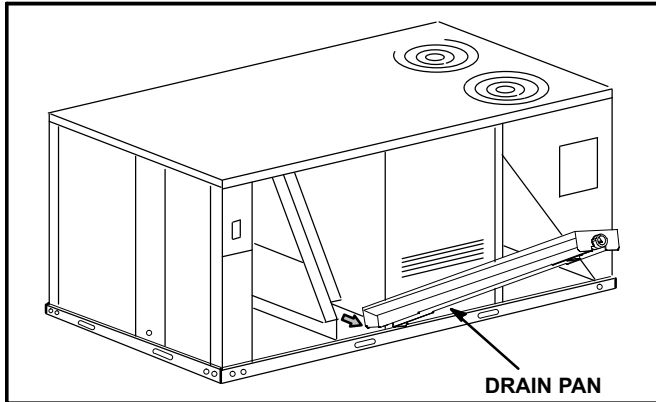

FIGURE 6

- 5- Make sure the cap over the unit bottom drain hole is secure.
- 6- Rotate the drain pan until the downward slope is toward the back of the unit. Slide the drain pan back into the unit. Be careful not to dislodge the cap over the bottom drain hole.
- 7- From the back side of the unit, pull the drain pan coupling through the rear condensate opening.
- 8- Replace the condensate drain mullion and reinstall eight screws.
- 9- Reinstall access doors.

Bottom Drain Connection

- 1- Remove heat access door. See figure 5.
- 2- Remove filter access door.
- 3- Remove eight screws holding condensate drain mullion and remove mullion.
- 4- Lift front edge of the drain pan (to clear bottom drain plug) and slide drain pan out of unit. See figure 6.

- 5- Turn the drain pan upside down and drill a pilot hole through the bottom of the drain pan in the center of the coupling. See figure 7.

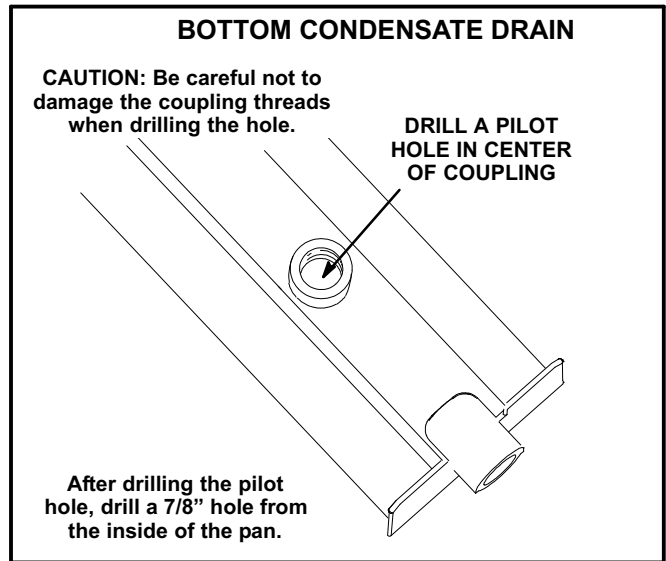

FIGURE 7

- 6- From the inside of the pan, use a Vari-Bit® bit to enlarge the hole to 7/8". Do not damage coupling threads.
- 7- Remove the cap over the unit bottom drain hole.
- 8- Slide the drain pan back into the unit.
- 9- From the back side of the unit, pull the drain pan coupling through the rear condensate opening.
- 10- From the front side of the unit, move the drain pan until the bottom coupling settles into the unit bottom drain opening. Once in place, check to make sure the coupling is still positioned through the rear condensate drain hole.
- 11- Use a field-provided 1" plug to seal side drain connection.
- 12- Replace the condensate drain mullion and reinstall eight screws.
- 13- Reinstall access doors.

Connect Gas Piping (Gas Units)

Before connecting field-provided piping, check with gas company or authorities having jurisdiction for local code requirements. When installing gas supply piping, length of run from gas meter must be considered in determining pipe size for 0.5" w.c. (.12kPa) maximum pressure drop. Do not use supply pipe smaller than unit gas connection. For natural gas units, operating pressure at the unit gas connection must be a minimum of 4.7" w.c. (1.19kPa) and a maximum of 10.5" (2.60kPa) w.c. For LP/propane gas units, operating pressure at the unit gas connection must be a minimum of 11" w.c. (2.74kPa) and a maximum of 13.0" w.c. (3.23kPa).

When making piping connections a drip leg should be installed on vertical pipe runs to serve as a trap for sediment or condensate. A 1/8" N.P.T. plugged tap is located on gas valve for test gauge connection. Refer to Heating Start-Up section for tap location. Install a ground joint union between the gas control manifold and the main manual shut-off valve. See figure 8 for gas supply piping entering outside the unit. Figure 9 shows bottom gas entry piping through the curb. Figure 10 shows bottom gas entry piping through the unit.

Compounds used on threaded joints of gas piping shall be resistant to the action of liquified petroleum gases.

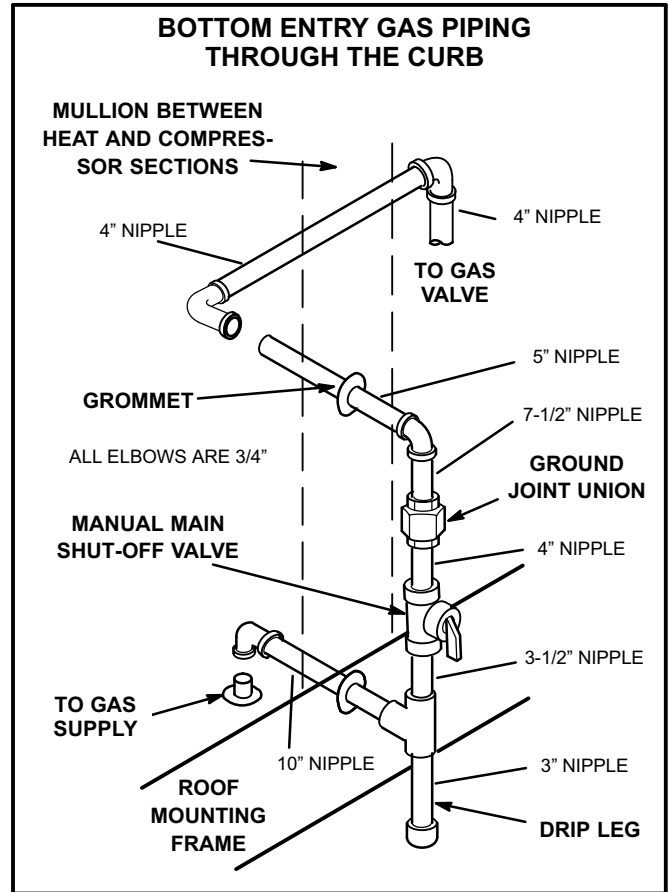

FIGURE 9

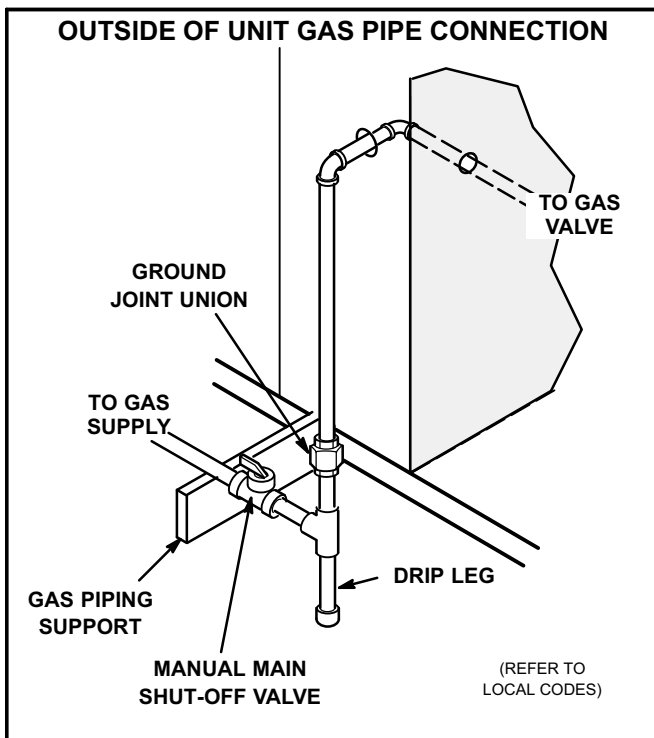

FIGURE 8

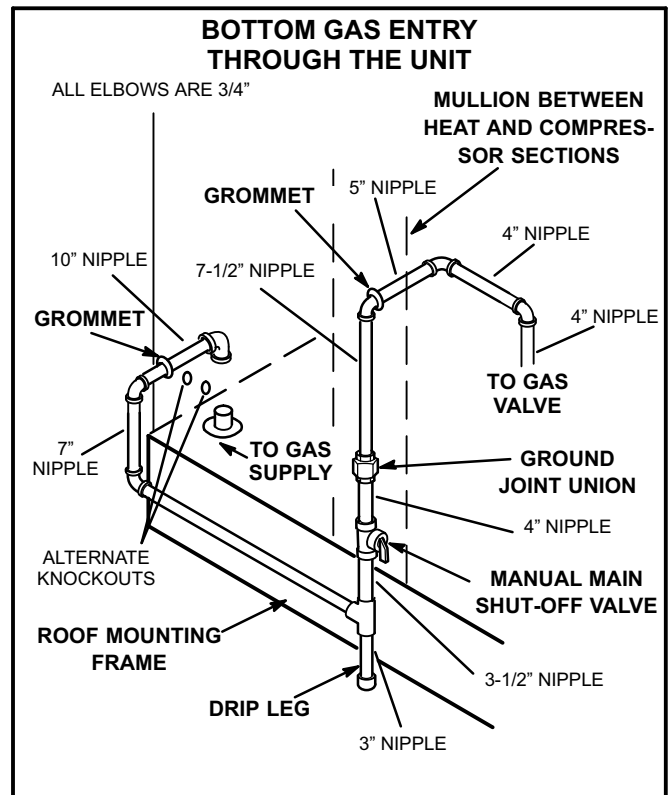

FIGURE 10

Pressure Test Gas Piping (Gas Units)

When pressure testing gas lines, the gas valve must be disconnected and isolated. Gas valves can be damaged if subjected to more than 0.5 psig (3.48kPa). See figure 11.

NOTE-Codes may require that manual main shut-off valve and union (furnished by installer) be installed in gas line external to unit. Union must be of the ground joint type.

After all connections have been made, check all piping connections for gas leaks. Also check existing unit gas connections up to the gas valve; loosening may occur during installation. Use a leak detection solution or other preferred means. Do not use matches candles or other sources of ignition to check for gas leaks.

⚠ CAUTION

Some soaps used for leak detection are corrosive to certain metals. Carefully rinse piping thoroughly after leak test has been completed. Do not use matches, candles, flame or othe sources of ignition to check for gas leaks.

⚠ WARNING

Danger of explosion. Can cause injury or product or property damage. Do not use matches, candles, flame or other sources of ignition to check for leaks.

NOTE-In case emergency shut down is required, turn off the main manual shut-off valve and disconnect main power to unit. These devices should be properly labeled by the installer.

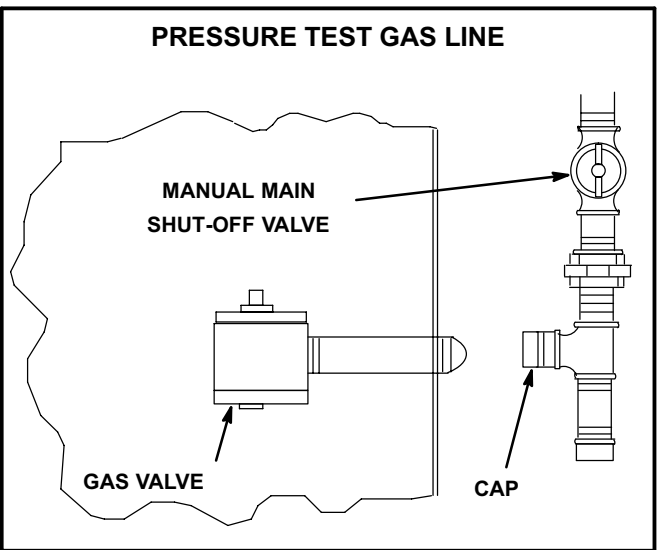

FIGURE 11

High Altitude Derate

Locate the high altitude conversion sticker in the unit literature bag. Fill out the conversion sticker and affix next to the unit nameplate.

Refer to table 1 for high altitude adjustments.

**TABLE 1
HIGH ALTITUDE DERATE**

Altitude Ft.*	Gas Manifold Pressure
2000-4500	See Unit Nameplate
4500 And Above	Derate 2% / 1000 Ft. Above Sea Level

*Units installed at 0-2000 feet do not need to be modified.

NOTE - This is the only permissible derate for these units.

Electrical Connections

POWER SUPPLY

Do not apply power or close disconnect switch until installation is complete. Refer to start-up directions. Refer closely to unit wiring diagram.

Refer to unit nameplate for minimum circuit ampacity and maximum fuse size.

- 1- 230/460/575 volt units are factory wired. **For 208V supply**, disconnect the pink wire (230V) at all control power transformer(s). Reconnect the pink wire (208V). Tape the exposed end of the 230V pink wire.
- 2- Route power through the bottom power entry area and connect to L1, L2, and L3 on the bottom of TB2 in control box for gas units or units equipped with electric heat. Route power to F4 on cooling only units (no electric heat). Route power to S48 disconnect switch when the option is factory-installed. See unit wiring diagram.
- 3- Connect separate 120v wiring to optional GFCI outlet pigtails.

CONTROL WIRING

A-Thermostat Location

Room thermostat mounts vertically on a standard 2" X 4" handy box or on any non-conductive flat surface.

Locate thermostat approximately 5 feet (1524mm) above the floor in an area with good air circulation at average temperature. Avoid locating the room thermostat where it might be affected by:

- drafts or dead spots behind doors and in corners
- hot or cold air from ducts
- radiant heat from sun or appliances
- concealed pipes and chimneys

B-Control Wiring

- 1- Route thermostat cable or wires from subbase to control box (refer to unit dimensions to locate bottom and side power entry).

IMPORTANT - Unless field thermostat wires are rated for maximum unit voltage, they must be routed away from line voltage wiring. Use wire ties located near the lower left corner of the controls hat section to secure thermostat cable.

Use 18 AWG wire for all applications using remotely installed electro-mechanical and electronic thermostats.

- 2- Install thermostat assembly in accordance with instructions provided with thermostat.
- 3- Connect thermostat wiring to TB1 terminal board on the lower side of the controls hat section. Wire as shown in figure 12 for electro-mechanical and electronic thermostats. If using other temperature control devices or energy management systems see instructions and wiring diagram provided by manufacturer.

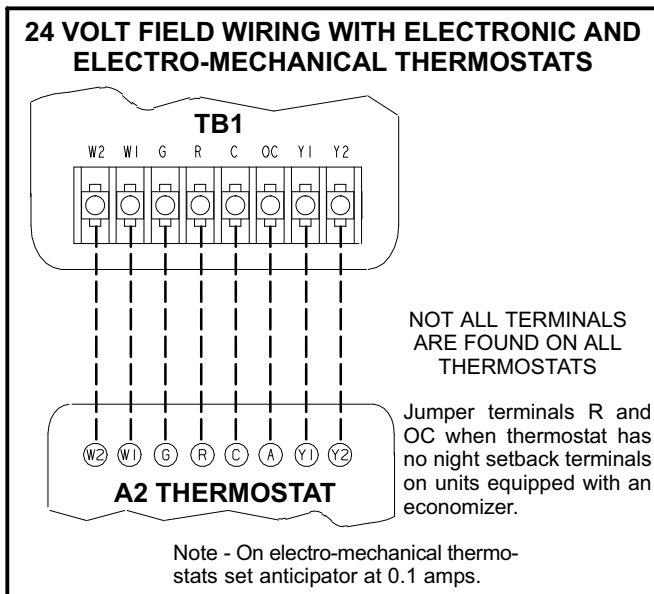

FIGURE 12

IMPORTANT-Terminal connections at the wall plate or subbase must be made securely. Loose control wire connections may allow unit to operate but not with proper response to room demand.

Unit Power-Up

A-General

- 1- Make sure that unit is installed in accordance with the installation instructions and applicable codes.
- 2- Inspect all electrical wiring, both field- and factory-installed, for loose connections. Tighten as required.
- 3- Check to ensure that refrigerant lines do not rub against the cabinet or against other refrigerant lines.
- 4- Check voltage at main unit power connection. Voltage must be within range listed on nameplate. If not, consult power company and have voltage condition corrected before starting unit.
- 5- Make sure filters are in place before start-up.
- 6- Make sure there is no heating, cooling, or blower demand from thermostat. Apply power to unit.

Blower Operation and Adjustments

⚠ IMPORTANT

Three phase scroll compressors must be phased sequentially for correct compressor and blower rotation. Follow "COOLING START-UP" section of installation instructions to ensure proper compressor and blower operation.

A-Blower Operation

Initiate blower demand at thermostat according to instructions provided with thermostat. Unit will cycle on thermostat demand. The following steps apply to applications using a typical electro-mechanical thermostat.

- 1- Blower operation is manually set at the thermostat subbase fan switch. With fan switch in **ON** position, blowers will operate continuously.
- 2- With fan switch in **AUTO** position, the blowers will cycle with demand. Blowers and entire unit will be off when system switch is in **OFF** position.

B-Blower Access

The blower assembly is secured to a sliding frame which allows the blower motor to be pulled out of the unit. See figure 13.

- 1- Loosen the reusable wire tie which secures the blower wiring to the blower motor mounting plate.
- 2- Remove and retain screws on either side of sliding frame. Pull frame toward outside of unit.
- 3- Slide frame back into original position when finished servicing. Reattach the blower wiring in the previous location on the blower motor base using the wire tie.
- 4- Replace retained screws on either side of the sliding frame.

C-Determining Unit CFM

- 1- The following measurements must be made with a dry indoor coil. Run blower without a cooling demand. Measure the indoor blower shaft RPM. Air filters must be in place when measurements are taken.
- 2- With all access panels in place, measure static pressure external to unit (from supply to return).
- 3- Referring to page 13, 14, or 15, use static pressure and RPM readings to determine unit CFM. Use pages 16 and 17 when installing units with any of the optional accessories listed.
- 4- The blower RPM can be adjusted at the motor pulley. Loosen Allen screw and turn adjustable pulley clockwise to increase CFM. Turn counterclockwise to decrease CFM. See figure 13. Do not exceed minimum and maximum number of pulley turns as shown in table 2.

**TABLE 2
MINIMUM AND MAXIMUM PULLEY ADJUSTMENT**

Belt	Minimum Turns Open	Maximum Turns Open
A Section	0	5
B Section	1*	6

*No minimum number of turns open when B belt is used on pulleys 6" O.D. or larger.

D-Blower Belt Adjustment

Maximum life and wear can be obtained from belts only if proper pulley alignment and belt tension are maintained. Tension new belts after a 24-48 hour period of operation. This will allow belt to stretch and seat in the pulley grooves. Make sure blower and motor pulleys are aligned as shown in figure 14.

- 1- Loosen four bolts securing motor base to mounting frame. See figure 13.

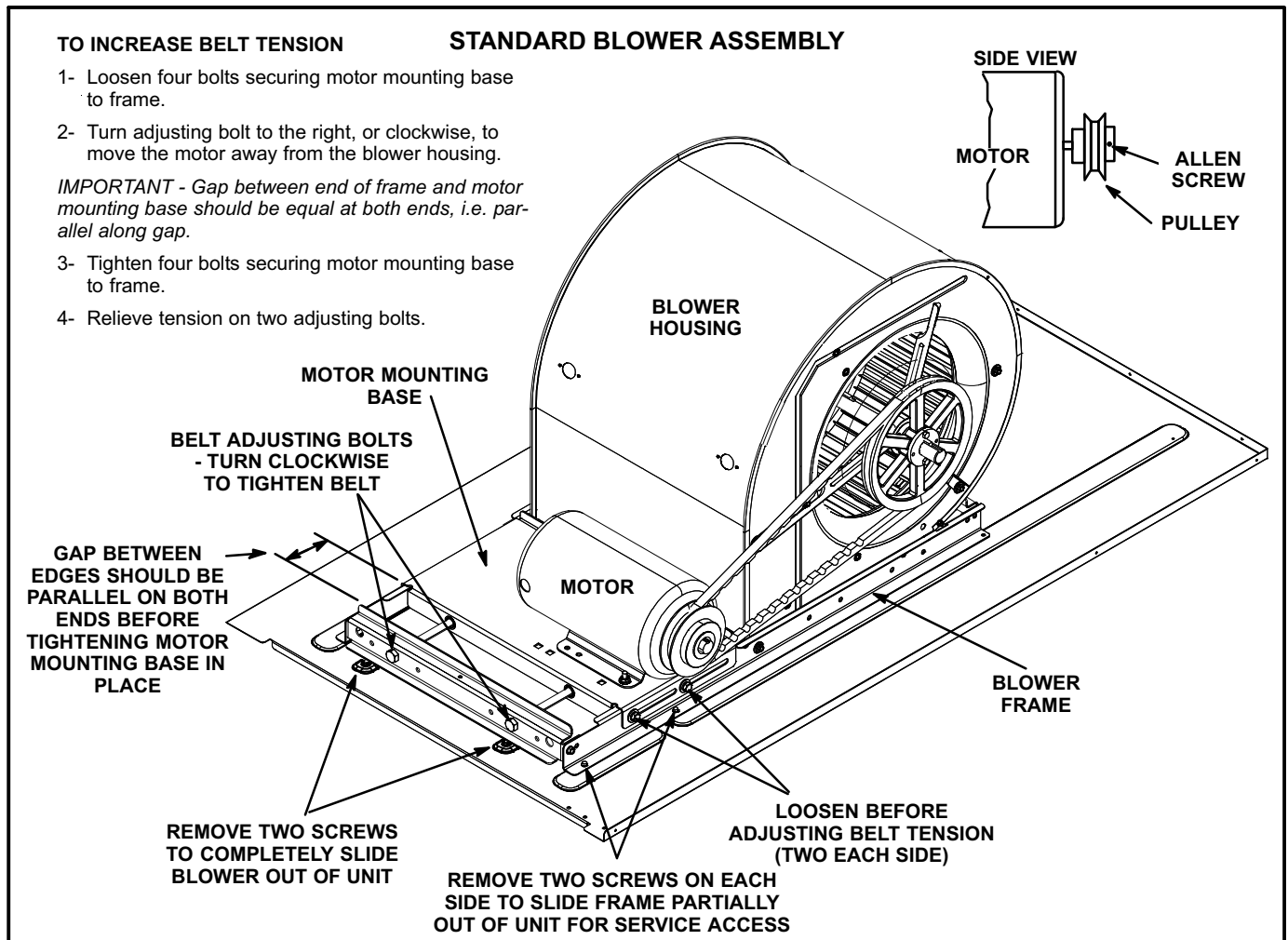

FIGURE 13

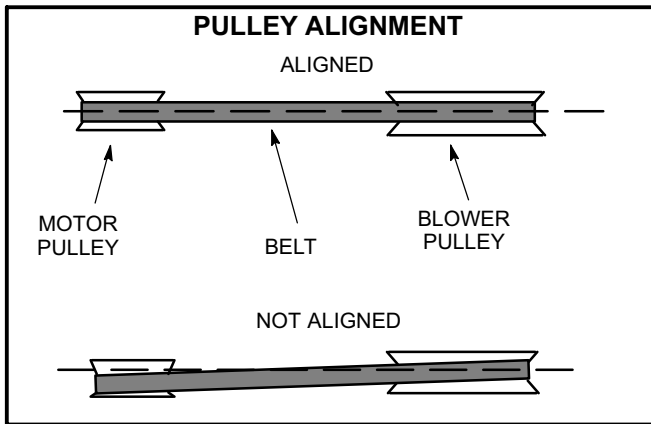

FIGURE 14

2- *To increase belt tension -*

Turn both adjusting bolts to the right, or clockwise, to move the motor outward and tighten the belt. This increases the distance between the blower motor and the blower housing.

To loosen belt tension -

Turn the adjusting bolts to the left, or counterclockwise to loosen belt tension.

IMPORTANT - Align top edges of blower motor base and mounting frame base parallel before tightening two bolts on the other side of base. Motor shaft and blower shaft must be parallel.

3- Tighten two bolts on each side of the motor mounting base. This secures the mounting base to the frame.

E-Check Belt Tension

Overtensioning belts shortens belt and bearing life. Check belt tension as follows:

- 1- Measure span length X. See figure 15.
- 2- Apply perpendicular force to center of span (X) with enough pressure to deflect belt 1/64" for every inch of span length or 1.5mm per 100mm of span length.

Example: Deflection distance of a 40" span would be 40/64" or 5/8".

Example: Deflection distance of a 400mm span would be 6mm.

- 3- Measure belt deflection force. For a new 2 and 3hp belt, the deflection force should be 5.0-7.0 lbs. (35-48kPa). For a new 5hp belt, the deflection force should be 7-10lbs. (48-69kPa).

A force below these values indicates an undertensioned belt. A force above these values indicates an overtensioned belt.

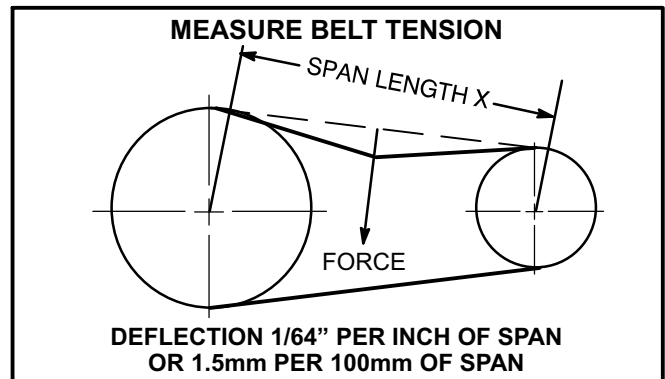

FIGURE 15

F-Field-Furnished Blower Drives

For field-furnished blower drives, use pages 13 through 17 to determine BHP and RPM required. Reference table 3 for drive component manufacturer's numbers.

BLOWER DATA

092 AND 102 BELT DRIVE BLOWER – BASE UNIT

BLOWER TABLE INCLUDES RESISTANCE FOR BASE UNIT ONLY (NO HEAT SECTION) WITH DRY INDOOR COIL AND AIR FILTERS IN PLACE. FOR ALL UNITS ADD:

- 1 – Wet indoor coil air resistance of selected unit.
- 2 – Any factory installed options air resistance (heat section, economizer, etc.)
- 3 – Any field installed accessories air resistance (duct resistance, diffuser, etc.)

Then determine from blower table blower motor output required.

See page 16 for wet coil and option/accessory air resistance data.

MINIMUM AIR VOLUME REQUIRED FOR USE WITH OPTIONAL ELECTRIC HEAT (Maximum Static Pressure - 2.0 in. w.g.)

7.5 kW, 15 kW, 22.5 kW, 30 kW and 45 kW - 2800 cfm

Total Air Volume cfm	Total Static Pressure – in. w.g.																										
	0.2		0.4		0.6		0.8		1.0		1.2		1.4		1.6		1.8		2		2.2		2.4		2.6		
	RPM	BHP	RPM	BHP	RPM	BHP	RPM	BHP	RPM	BHP	RPM	BHP	RPM	BHP	RPM	BHP	RPM	BHP	RPM	BHP	RPM	BHP	RPM	BHP	RPM	BHP	RPM
2250	---	---	---	---	707	0.14	753	0.5	800	0.84	847	1.15	892	1.38	934	1.53	979	1.65	1051	1.86	1126	2.12	1183	2.36	1238	2.62	
2500	---	---	---	---	714	0.29	758	0.64	803	0.97	849	1.26	893	1.48	936	1.63	983	1.75	1052	1.96	1124	2.22	1184	2.49	1241	2.77	
2750	---	---	680	0.11	721	0.45	763	0.78	807	1.09	852	1.37	896	1.58	940	1.74	989	1.88	1053	2.08	1121	2.34	1185	2.63	1244	2.93	
3000	---	---	689	0.29	728	0.61	770	0.93	812	1.23	856	1.49	901	1.7	947	1.87	996	2.02	1055	2.21	1120	2.47	1186	2.78	1248	3.1	
3250	661	0.17	698	0.46	737	0.78	777	1.09	819	1.38	862	1.63	908	1.84	955	2.01	1004	2.17	1059	2.36	1122	2.62	1189	2.94	1252	3.28	
3500	672	0.36	708	0.65	746	0.95	786	1.25	827	1.53	870	1.78	916	1.99	965	2.17	1013	2.33	1065	2.52	1126	2.79	1193	3.12	1257	3.47	
3750	684	0.56	719	0.85	756	1.14	795	1.43	836	1.7	880	1.95	927	2.16	976	2.34	1023	2.51	1073	2.71	1133	2.98	1198	3.32	1263	3.67	
4000	697	0.78	731	1.05	768	1.34	807	1.62	848	1.89	892	2.13	940	2.34	988	2.53	1034	2.71	1083	2.91	1141	3.19	1205	3.53	1270	3.89	
4250	710	1	745	1.27	781	1.55	819	1.83	861	2.09	906	2.33	954	2.55	1001	2.74	1046	2.93	1094	3.14	1151	3.42	1214	3.76	1278	4.12	
4500	725	1.23	759	1.5	795	1.77	834	2.05	875	2.31	921	2.55	970	2.77	1015	2.97	1059	3.16	1106	3.38	1162	3.67	1224	4	1287	4.36	
4750	741	1.48	775	1.74	811	2.01	850	2.29	892	2.55	939	2.79	986	3.01	1030	3.22	1072	3.42	1119	3.64	1174	3.93	1235	4.26	1297	4.61	
5000	758	1.74	791	2	828	2.27	867	2.54	911	2.8	958	3.05	1004	3.27	1046	3.48	1087	3.69	1134	3.92	1188	4.21	1247	4.53	1309	4.88	
5250	775	2.01	809	2.27	846	2.55	886	2.82	931	3.08	977	3.33	1021	3.56	1062	3.77	1103	3.98	1150	4.22	1203	4.5	1261	4.82	1321	5.16	
5500	794	2.3	829	2.56	866	2.84	907	3.11	952	3.38	997	3.63	1039	3.86	1079	4.08	1120	4.29	1166	4.53	1218	4.8	1275	5.12	1335	5.45	
5750	814	2.61	849	2.88	887	3.15	930	3.43	974	3.7	1018	3.95	1058	4.19	1096	4.41	1138	4.62	1183	4.85	1235	5.12	1290	5.43	---	---	
6000	836	2.93	871	3.21	910	3.49	953	3.77	997	4.04	1038	4.3	1077	4.54	1115	4.75	1156	4.96	1202	5.19	1252	5.45	1307	5.75	---	---	

BLOWER DATA

120 BELT DRIVE BLOWER – BASE UNIT

BLOWER TABLE INCLUDES RESISTANCE FOR BASE UNIT ONLY (NO HEAT SECTION) WITH DRY INDOOR COIL AND AIR FILTERS IN PLACE. FOR ALL UNITS ADD:

- 1 – Wet indoor coil air resistance of selected unit.
- 2 – Any factory installed options air resistance (heat section, economizer, etc.)
- 3 – Any field installed accessories air resistance (duct resistance, diffuser, etc.)

Then determine from blower table blower motor output required.

See page 16 for wet coil and option/accessory air resistance data.

MINIMUM AIR VOLUME REQUIRED FOR USE WITH OPTIONAL ELECTRIC HEAT (Maximum Static Pressure - 2.0 in. w.g.)

15 kW, 22.5 kW, 30 kW and 45 kW - 2800 cfm

60 kW - 4000 cfm

Total Air Volume cfm	Total Static Pressure – in. w.g.																										
	0.2		0.4		0.6		0.8		1.0		1.2		1.4		1.6		1.8		2		2.2		2.4		2.6		
	RPM	BHP	RPM	BHP	RPM	BHP	RPM	BHP	RPM	BHP	RPM	BHP	RPM	BHP	RPM	BHP	RPM	BHP	RPM	BHP	RPM	BHP	RPM	BHP	RPM	BHP	RPM
2250	---	---	---	---	---	---	719	0.31	768	0.67	818	1.01	871	1.29	926	1.5	979	1.64	1025	1.75	1066	1.88	1108	2.08	1155	2.38	
2500	---	---	---	---	683	0.11	728	0.47	775	0.82	825	1.14	878	1.41	934	1.62	987	1.77	1033	1.89	1075	2.05	1119	2.27	1166	2.58	
2750	---	---	---	---	693	0.3	737	0.64	783	0.97	833	1.28	886	1.54	943	1.75	996	1.91	1042	2.06	1085	2.23	1130	2.48	1178	2.81	
3000	---	---	663	0.15	704	0.48	747	0.82	793	1.13	842	1.43	895	1.69	953	1.9	1007	2.08	1052	2.24	1096	2.44	1142	2.71	1191	3.05	
3250	637	0.03	676	0.36	716	0.68	758	1	803	1.31	852	1.6	907	1.85	965	2.08	1018	2.27	1064	2.45	1108	2.67	1155	2.95	1205	3.3	
3500	651	0.26	689	0.57	728	0.88	770	1.19	815	1.49	865	1.78	920	2.04	979	2.27	1031	2.47	1076	2.67	1122	2.92	1169	3.22	1220	3.58	
3750	665	0.49	703	0.79	742	1.1	783	1.4	828	1.69	879	1.97	935	2.24	993	2.48	1044	2.7	1090	2.92	1136	3.19	1185	3.5	1235	3.87	
4000	681	0.74	718	1.03	757	1.32	798	1.62	843	1.91	894	2.19	952	2.46	1009	2.72	1059	2.95	1105	3.2	1152	3.48	1201	3.81	1252	4.18	
4250	697	0.99	734	1.27	772	1.56	813	1.85	859	2.14	911	2.42	970	2.71	1025	2.98	1074	3.23	1121	3.49	1169	3.79	1218	4.13	1269	4.51	
4500	714	1.25	751	1.53	789	1.81	830	2.1	876	2.39	930	2.68	988	2.97	1042	3.26	1091	3.53	1138	3.81	1186	4.12	1236	4.47	1287	4.85	
4750	732	1.53	768	1.8	806	2.08	848	2.36	895	2.65	950	2.96	1007	3.27	1060	3.57	1109	3.86	1157	4.16	1205	4.47	1255	4.82	1306	5.2	
5000	750	1.82	786	2.09	825	2.36	867	2.65	915	2.94	971	3.26	1027	3.59	1079	3.91	1128	4.21	1176	4.52	1225	4.84	1275	5.19	---	---	
5250	770	2.12	806	2.38	844	2.66	887	2.95	937	3.25	993	3.59	1048	3.95	1100	4.28	1149	4.59	1197	4.9	1246	5.23	1295	5.58	---	---	
5500	789	2.43	825	2.7	864	2.97	908	3.26	959	3.59	1015	3.96	1070	4.34	1121	4.68	1170	4.99	1219	5.31	1267	5.64	---	---	---	---	
5750	810	2.76	846	3.03	885	3.3	929	3.6	982	3.96	1039	4.37	1093	4.76	1144	5.1	1193	5.42	1241	5.73	---	---	---	---	---	---	
6000	830	3.1	866	3.37	906	3.65	952	3.97	1007	4.37	1064	4.81	1118	5.2	1168	5.54	---	---	---	---	---	---	---	---	---	---	

BLOWER DATA

150 BELT DRIVE BLOWER – BASE UNIT

BLOWER TABLE INCLUDES RESISTANCE FOR BASE UNIT ONLY (NO HEAT SECTION) WITH DRY INDOOR COIL AND AIR FILTERS IN PLACE. FOR ALL UNITS ADD:

- 1 – Wet indoor coil air resistance of selected unit.
- 2 – Any factory installed options air resistance (heat section, economizer, etc.)
- 3 – Any field installed accessories air resistance (duct resistance, diffuser, etc.)

Then determine from blower table blower motor output required.

See page 16 for wet coil and option/accessory air resistance data.

MINIMUM AIR VOLUME REQUIRED FOR USE WITH OPTIONAL ELECTRIC HEAT (Maximum Static Pressure - 2.0 in. w.g.)

15 kW, 22.5 kW, 30 kW and 45 kW - 2800 cfm

60 kW - 4000 cfm

Total Air Volume cfm	Total Static Pressure – in. w.g.																										
	0.2		0.4		0.6		0.8		1.0		1.2		1.4		1.6		1.8		2		2.2		2.4		2.6		
	RPM	BHP	RPM	BHP	RPM	BHP	RPM	BHP	RPM	BHP	RPM	BHP	RPM	BHP	RPM	BHP	RPM	BHP	RPM	BHP	RPM	BHP	RPM	BHP	RPM	BHP	RPM
2250	587	0.08	637	0.31	690	0.56	746	0.82	805	1.06	865	1.28	927	1.46	985	1.57	1034	1.68	1084	1.8	1136	1.95	1189	2.13	1239	2.32	
2500	601	0.24	650	0.47	703	0.71	757	0.95	815	1.18	875	1.4	938	1.57	996	1.7	1045	1.82	1095	1.96	1147	2.13	1201	2.31	1253	2.52	
2750	616	0.41	664	0.62	715	0.85	769	1.09	826	1.31	886	1.52	950	1.7	1008	1.84	1056	1.98	1105	2.13	1158	2.31	1213	2.52	1266	2.73	
3000	632	0.58	679	0.79	729	1.01	782	1.23	839	1.45	899	1.66	963	1.84	1019	1.99	1066	2.15	1115	2.32	1169	2.51	1225	2.73	1279	2.96	
3250	649	0.76	695	0.96	744	1.17	797	1.39	853	1.6	913	1.81	976	1.99	1030	2.16	1076	2.33	1126	2.52	1181	2.73	1237	2.95	1293	3.19	
3500	666	0.95	712	1.14	761	1.35	813	1.55	868	1.76	929	1.97	990	2.17	1041	2.35	1087	2.53	1138	2.73	1193	2.95	1250	3.19	1307	3.43	
3750	685	1.16	730	1.34	779	1.53	830	1.74	886	1.94	946	2.15	1005	2.36	1053	2.55	1098	2.75	1150	2.96	1207	3.2	1264	3.44	1321	3.69	
4000	706	1.37	750	1.55	798	1.73	849	1.93	905	2.14	965	2.35	1019	2.57	1065	2.78	1111	2.99	1164	3.22	1221	3.46	1279	3.7	1336	3.96	
4250	727	1.6	772	1.77	819	1.95	871	2.15	926	2.35	984	2.58	1034	2.8	1079	3.02	1126	3.25	1180	3.49	1236	3.73	1295	3.98	1352	4.24	
4500	750	1.84	795	2.01	843	2.19	894	2.38	949	2.59	1003	2.83	1050	3.07	1094	3.3	1142	3.53	1196	3.77	1253	4.02	1311	4.27	1369	4.53	
4750	775	2.1	820	2.26	868	2.44	919	2.63	972	2.86	1023	3.11	1067	3.36	1112	3.6	1161	3.84	1215	4.08	1271	4.32	1329	4.57	1387	4.83	
5000	802	2.37	847	2.53	895	2.71	945	2.91	997	3.16	1044	3.43	1087	3.69	1131	3.93	1181	4.16	1235	4.4	1291	4.64	1349	4.89	1406	5.14	
5250	831	2.67	876	2.83	924	3.01	973	3.23	1022	3.5	1066	3.78	1108	4.04	1153	4.27	1203	4.51	1256	4.74	1312	4.98	1369	5.22	1426	5.47	
5500	862	2.98	907	3.14	955	3.33	1002	3.59	1048	3.89	1090	4.17	1132	4.42	1177	4.64	1226	4.87	1278	5.09	1333	5.32	1390	5.56	---	---	
5750	895	3.31	940	3.48	987	3.71	1032	4.01	1075	4.32	1116	4.59	1158	4.82	1202	5.03	1251	5.24	1302	5.46	1356	5.68	---	---	---	---	
6000	931	3.66	976	3.87	1021	4.16	1064	4.49	1104	4.78	1144	5.02	1185	5.23	1229	5.43	1276	5.63	---	---	---	---	---	---	---	---	

BLOWER DATA

FACTORY INSTALLED OPTIONS/FIELD INSTALLED ACCESSORY AIR RESISTANCE - in. w.g.

Air Volume cfm	Wet Indoor Coil			Gas Heat Exchanger			Electric Heat	Economizer	Filters		Return Air Adaptor Plate
	092, 102	120	150	Standard Heat	Medium heat	High Heat			MERV 8	MERV 13	
2250	0.07	0.10	0.13	0.07	0.07	0.08	0.04	0.08	0.01	0.04	0.00
2500	0.09	0.12	0.15	0.09	0.10	0.11	0.04	0.11	0.01	0.05	0.00
2750	0.09	0.12	0.17	0.09	0.11	0.12	0.05	0.12	0.02	0.05	0.00
3000	0.11	0.15	0.19	0.11	0.12	0.13	0.06	0.13	0.02	0.06	0.02
3250	0.13	0.18	0.23	0.12	0.15	0.16	0.06	0.15	0.02	0.06	0.02
3500	0.14	0.21	0.26	0.12	0.16	0.17	0.09	0.15	0.03	0.07	0.04
3750	0.16	0.23	0.29	0.14	0.19	0.20	0.09	0.15	0.03	0.08	0.07
4000	0.17	0.25	0.31	0.14	0.21	0.22	0.09	0.19	0.04	0.08	0.09
4250	0.20	0.27	0.34	0.14	0.24	0.28	0.13	0.19	0.04	0.09	0.11
4500	0.21	0.30	0.37	0.15	0.26	0.32	0.14	0.22	0.04	0.09	0.12
4750	0.23	0.32	0.40	0.16	0.29	0.37	0.17	0.25	0.05	0.10	0.16
5000	0.26	0.35	0.43	0.16	0.34	0.43	0.20	0.29	0.06	0.10	0.18
5250	0.27	0.36	0.46	0.16	0.37	0.47	0.22	0.32	0.06	0.11	0.19
5500	0.29	0.40	0.50	0.18	0.44	0.54	0.25	0.34	0.07	0.12	0.22
5750	0.32	0.43	0.56	0.19	0.49	0.59	0.31	0.45	0.07	0.12	0.25
6000	0.33	0.46	0.59	0.20	0.54	0.64	0.33	0.52	0.08	0.13	0.27

**TABLE 3
MANUFACTURER'S NUMBERS**

DRIVE NO.	DRIVE COMPONENTS					
	ADJUSTABLE SHEAVE		FIXED SHEAVE		BELT	
	BROWNING NO.	OEM PART NO.	BROWNING NO.	OEM PART NO.	BROWNING NO.	OEM PART NO.
1	1VP34x7/8	31K6901	AK61x1	100244-20	AX54	100245-25
2	1VP40x7/8	79J0301	AK59x1	31K6801	AX55	100245-26
3	1VP34x7/8	31K6901	AK46x1	100244-17	AX52	100245-33
4	1VP44x7/8	53J9601	AK74x1	100244-21	AX58	100245-34
5	1VP50x7/8	98J0001	AK69x1	37L4701	AX58	100245-34
6	1VP50x7/8	98J0001	AK64x1	12L2501	AX57	100245-28
10	1VP50x1-1/8	P-8-1977	BK77x1	49K4001	BX59	59A5001
11	1VP50x1-1/8	P-8-1977	BK67x1	100244-24	BX57	78L5301
12	1VP50x1-1/8	P-8-1977	BK62x1	100244-23	BX56	100245-11

Cooling Start-Up

A-Operation

- 1- Initiate first and second stage cooling demands according to instructions provided with thermostat.
- 2- *No Economizer Installed in Unit* -
A first-stage cooling demand (Y1) will energize compressor 1 and both condenser fans. An increased cooling demand (Y2) will energize compressor 2.
- Units Equipped With Economizer* -
When outdoor air is acceptable, a first-stage cooling demand (Y1) will energize the economizer. An increased cooling demand (Y2) will energize compressor 1 and both condenser fans. When outdoor air is not acceptable unit will operate as though no economizer is installed.
- 3- Units contain two refrigerant circuits or stages. See figure 16.
- 4- Each refrigerant circuit is separately charged with R-410A refrigerant. See unit rating plate for correct amount of charge.
- 5- Refer to Cooling Operation and Adjustment section for proper method to check refrigerant charge.

B-Three Phase Scroll Compressor Voltage Phasing

Three phase scroll compressors must be phased sequentially to ensure correct compressor and blower rotation and operation. Compressor and blower are wired in phase at the factory. Power wires are color-coded as follows: line 1-red, line 2-yellow, line 3-blue.

- 1- Observe suction and discharge pressures and blower rotation on unit start-up.

If pressure differential is not observed or blower rotation is not correct:

- 2- Suction pressure must drop, discharge pressure must rise, and blower rotation must match rotation marking.
- 3- Disconnect all remote electrical power supplies.
- 4- Reverse any two field-installed wires connected to the line side of K3, TB2 or F4. Do not reverse wires at blower contactor or compressors.
- 5- Make sure the connections are tight.

Discharge and suction pressures should operate at their normal start-up ranges.

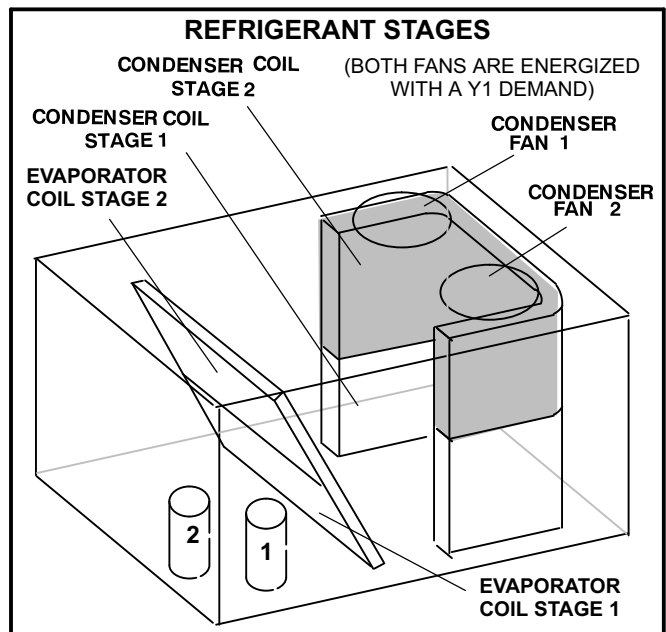

FIGURE 16

C-Refrigerant Charge and Check

WARNING-Do not exceed nameplate charge under any condition.

This unit is factory charged and should require no further adjustment. If the system requires additional refrigerant, reclaim the charge, evacuate the system, and add required nameplate charge.

*NOTE - System charging is not recommended below 60°F (15°C). In temperatures below 60°F (15°C), the charge **must** be weighed into the system.*

If weighing facilities are not available, or to check the charge, use the following procedure:

- 1- Attach gauge manifolds and operate unit in cooling mode with economizer disabled until system stabilizes (approximately five minutes). Make sure outdoor air dampers are closed.
- 2- Check each stage separately with all stages operating.
- 3- Use a thermometer to accurately measure the outdoor ambient temperature.
- 4- Apply the outdoor temperature to tables 4 through 7 to determine normal operating pressures. Pressures are listed for sea level applications at 80°F dry bulb and 67°F wet bulb return air.
- 5- Compare the normal operating pressures to the pressures obtained from the gauges. Minor variations in these pressures may be expected due to differences in installations. Significant differences could mean that the system is not properly charged or that a problem exists with some component in the system. **Correct any system problems before proceeding.**
- 6- If discharge pressure is high, remove refrigerant from the system. If discharge pressure is low, add refrigerant to the system.
 - Add or remove charge in increments.
 - Allow the system to stabilize each time refrigerant is added or removed.
- 7- Use the following approach method along with the normal operating pressures to confirm readings.

**TABLE 4
KGA/KCA092S NORMAL OPERATING PRESSURES**

Outdoor Coil Entering Air Temp	CIRCUIT 1		CIRCUIT 2	
	Dis-charge ±10 psig	Suction ±5 psig	Dis-charge ±10 psig	Suction ±5 psig
65° F	260	130	269	132
75° F	301	133	311	133
85° F	343	135	354	136
95° F	388	138	401	139
105° F	435	140	449	141
115° F	481	142	497	144

**TABLE 5
KCA/KGA102S NORMAL OPERATING PRESSURES**

Outdoor Coil Entering Air Temp	CIRCUIT 1		CIRCUIT 2	
	Dis-charge ±10 psig	Suction ±5 psig	Dis-charge ±10 psig	Suction ±5 psig
65° F	262	128	270	129
75° F	299	131	310	131
85° F	342	134	353	134
95° F	386	137	399	136
105° F	434	140	448	139
115° F	487	143	501	142

**TABLE 6
KCA/KGA120S NORMAL OPERATING PRESSURES**

Outdoor Coil Entering Air Temp	CIRCUIT 1		CIRCUIT 2	
	Dis-charge ±10 psig	Suction ±5 psig	Dis-charge ±10 psig	Suction ±5 psig
65° F	275	135	282	136
75° F	313	137	323	138
85° F	355	140	366	141
95° F	400	142	414	143
105° F	447	145	464	145
115° F	499	148	517	148

**TABLE 7
KCA/KGA150S NORMAL OPERATING PRESSURES**

Outdoor Coil Entering Air Temp	CIRCUIT 1		CIRCUIT 2	
	Dis-charge ±10 psig	Suction ±5 psig	Dis-charge ±10 psig	Suction ±5 psig
65° F	279	132	283	136
75° F	318	134	323	138
85° F	360	136	364	139
95° F	406	138	411	140
105° F	456	141	462	142
115° F	508	145	515	145

D-Charge Verification - Approach Method-AHRI Testing

- 1- Using the same thermometer, compare liquid temperature (at condenser outlet) to outdoor ambient temperature.

Approach Temperature = Liquid temperature minus ambient temperature.

- 2- Approach temperature should match values shown in table 8. An approach temperature greater than this value indicates an undercharge. An approach temperature less than this value indicates an overcharge.

**TABLE 8
APPROACH TEMPERATURE**

Unit	Liquid Temp. Minus Ambient Temp.	
	1st Stage	2nd Stage
092	9°F ± 1 (5.0°C ± 0.5)	8°F ± 1 (4.4°C ± 0.5)
102	7°F ± 1 (3.9°C ± 0.5)	6°F ± 1 (3.3°C ± 0.5)
120	8°F ± 1 (4.4°C ± 0.5)	6°F ± 1 (3.3°C ± 0.5)
150	6°F ± 1 (3.3°C ± 0.5)	6°F ± 1 (3.3°C ± 0.5)

3- The approach method is not valid for grossly over or undercharged systems. Use tables 4 through 7 as a guide for typical operating pressures.

E-Compressor Controls

See unit wiring diagram to determine which controls are used on each unit. Optional controls are identified on wiring diagrams by arrows at junction points.

1- Freezestats (S49, S50)

Switches de-energize compressors when evaporator coil temperature falls below 29°F (-2°C) to prevent evaporator freeze-up. Switches reset when evaporator coil temperature reaches 58°F (15°C).

Gas Heat Start-Up (Gas Units)

FOR YOUR SAFETY READ BEFORE LIGHTING

⚠ WARNING	
	Electric shock hazard. Can cause injury or death. Do not use this unit if any part has been under water. Immediately call a qualified service technician to inspect the unit and to replace any part of the control system and any gas control which has been under water.

⚠ WARNING	
	Danger of explosion. Can cause injury or product or property damage. If overheating occurs or if gas supply fails to shut off, shut off the manual gas valve to the appliance before shutting off electrical supply.

⚠ WARNING	
	Electric shock hazard. Can cause injury or death. Before attempting to perform any service or maintenance, turn the electrical power to unit OFF at disconnect switch(es). Unit may have multiple power supplies.

⚠ WARNING	
SMOKE POTENTIAL	
The heat exchanger in this unit could be a source of smoke on initial firing. Take precautions with respect to building occupants and property. Vent initial supply air outside when possible.	

BEFORE LIGHTING smell all around the appliance area for gas. Be sure to smell next to the floor because some gas is heavier than air and will settle on the floor.

Use only your hand to push in or turn the gas control knob. Never use tools. If the knob will not push in or turn by hand, do not try to repair it, call a qualified service technician. Force or attempted repair may result in a fire or explosion.

⚠ WARNING	
	Danger of explosion. Can cause injury or death. Do not attempt to light manually. Unit has a direct spark ignition system.

This unit is equipped with an automatic spark ignition system. There is no pilot. In case of a safety shutdown, move thermostat switch to **OFF** and return the thermostat switch to **HEAT** to reset ignition control.

A-Placing Unit In Operation

⚠ WARNING	
	Danger of explosion and fire. Can cause injury or product or property damage. You must follow these instructions exactly.

Gas Valve Operation for Honeywell VR8205Q/VR8305Q (figure 17)

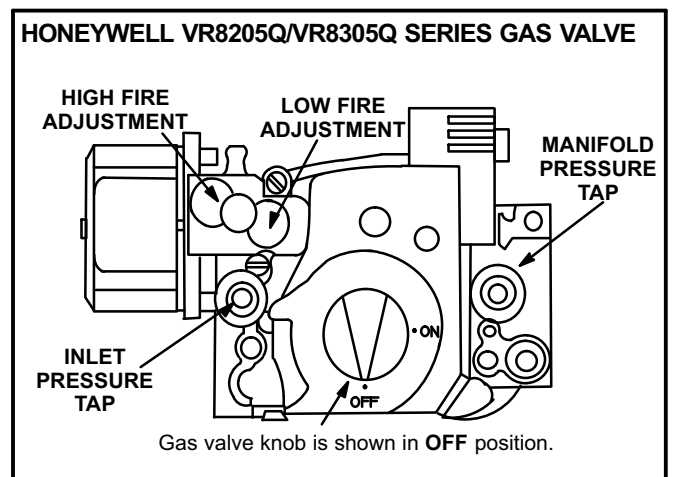





FIGURE 17

- 1- Set thermostat to lowest setting.
- 2- Turn off all electrical power to appliance.
- 3- This appliance is equipped with an ignition device which automatically lights the burner. Do **not** try to light the burner by hand.
- 4- Open or remove the heat section access panel.

- 5- Turn the knob on the gas valve clockwise  to "OFF". Do not force.
- 6- Turn the knob on the gas valve counterclockwise  to "ON". Do not force.
- 7- Close or replace the heat section access panel.
- 8- Turn on all electrical power to appliance.
- 9- Set thermostat to desired setting.
- 10- The ignition sequence will start.
- 11- If the appliance does not light the first time (gas line not fully purged), it will attempt up to two more ignitions before locking out.
- 12- If lockout occurs, repeat steps 1 through 10.
- 13- If the appliance will not operate, follow the instructions "Turning Off Gas to Appliance" and call your service technician or gas supplier.

Turning Off Gas to Unit

- 1- If using an electromechanical thermostat, set to the lowest setting.
- 2- Before performing any service, turn off all electrical power to the appliance.
- 3- Open or remove the heat section access panel.
- 4- Turn the knob on the gas valve clockwise  to "OFF". Do not force.
- 5- Close or replace the heat section access panel.

⚠ WARNING	
	Danger of explosion. Can cause injury or death. Do not attempt to light manually. Unit has a direct spark ignition system.

Heating Operation and Adjustments

(Gas Units)

A-Heating Sequence of Operation

- 1- On a heating demand the combustion air inducer starts immediately.
- 2- Combustion air pressure switch proves inducer operation. After a 30-second pre-purge, power is allowed to ignition control. Switch is factory set and requires no adjustment.
- 3- Spark ignitor energizes and gas valve solenoid opens.
- 4- Spark ignites gas, ignition sensor proves the flame and combustion continues.

- 5- If flame is not detected after first ignition trial, ignition control will repeat steps 3 and 4 two more times before locking out the gas valve.
- 6- For troubleshooting purposes, an ignition attempt after lock out may be re-established manually. Move thermostat to "OFF" and return thermostat switch to "HEAT" position.

B-Ignition Control Diagnostic LED's

**TABLE 9
IGNITION CONTROL HEARTBEAT LED STATUS**

LED Flashes	Indicates
Slow	Normal operation. No call for heat.
Fast	Normal operation. Call for heat.
Steady Off	Internal control fault OR no power to control OR Gas Valve Relay Fault.
Steady On	Control internal failure.
2	Lockout. Failed to detect or sustain flame.
3	Prove switch open or closed or rollout switch open.
4	Limit switch is open and/or limit has opened three times.
5	Flame sensed but gas valve solenoid not energized.

C-Limit Controls

Limit controls are factory-set and are not adjustable. The primary limit is located on the blower deck to the right of blower assembly.

D-Heating Adjustment

Main burners are factory-set and do not require adjustment.

The following manifold pressures are listed on the gas valve.

- Natural Gas Units - Low Fire - 1.6" w.c. (not adjustable)
- Natural Gas Units - High Fire - 3.7" w.c.
- LP Gas Units - Low Fire - 5.5" w.c. (not adjustable)
- LP Gas Units - High Fire - 10.5" w.c.

Electric Heat Start-Up (KCA Units)

Optional electric heat will stage on and cycle with thermostat demand. Number of stages of electric heat will vary depending on electric heat assembly. See electric heat wiring diagram on unit for sequence of operation.

Service

The unit should be inspected once a year by a qualified service technician.

⚠ CAUTION

Label all wires prior to disconnection when servicing controls. Wiring errors can cause improper and dangerous operation. Verify proper operation after servicing.

⚠ WARNING

Product contains fiberglass wool. Disturbing the insulation in this product during installation, maintenance, or repair will expose you to fiberglass wool. Breathing this may cause lung cancer. (Fiberglass wool is known to the State of California to cause cancer.) Fiberglass wool may also cause respiratory, skin, and eye irritation. To reduce exposure to this substance or for further information, consult material safety data sheets available from address shown on unit nameplate or contact your supervisor.

A-Filters

Units are equipped with four 20 X 25 X 2" filters. Filters should be checked monthly and replaced when necessary with filters of like kind and size. Take note of air flow direction marking on filter frame when reinstalling filters. See figure 18.

NOTE-Filters must be U.L.C. certified or equivalent for use in Canada.

B-Lubrication

All motors are lubricated at the factory. No further lubrication is required.

C-Burners (Gas Units)

Periodically examine burner flames for proper appearance during the heating season. Before each heating season examine the burners for any deposits or blockage which may have occurred.

Clean burners as follows:

- 1- Turn off both electrical power and gas supply to unit.

- 2- Remove burner compartment access panel.
- 3- Remove two screws securing burners to burner support and lift the burners from the orifices. See figure 19. Clean as necessary.
- 4- Locate the ignitor under the left burners. Check ignitor spark gap with appropriately sized twist drills or feeler gauges. See figure 20.

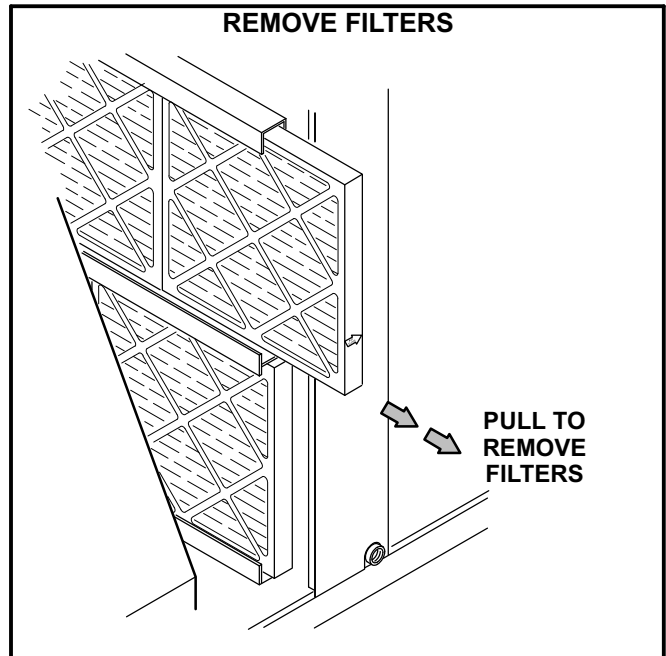

FIGURE 18

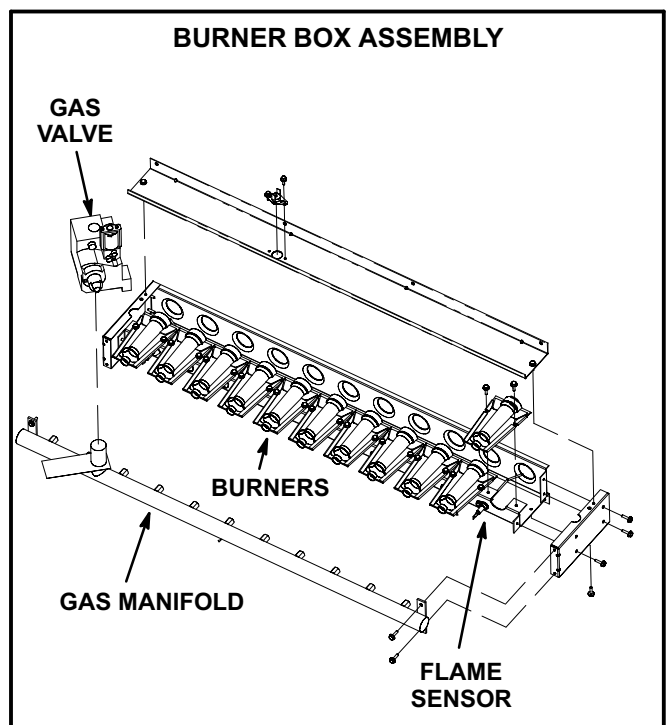

FIGURE 19

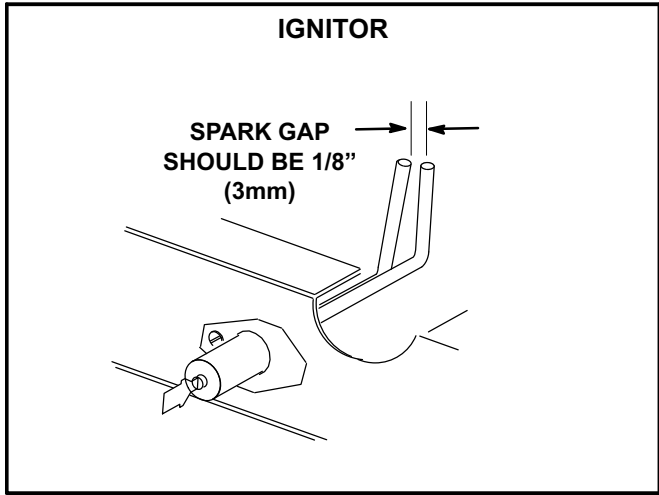

FIGURE 20

- 5- Check the alignment of the ignitor and the sensor as shown in figure 21 and table 10.
- 6- Replace burners and screws securing burner.

⚠ WARNING

Danger of explosion. Can cause injury or death. Do not overtighten main burner mounting screws. Snug tighten only.

TABLE 10

Dimension	Unit Btuh Input	Length - in. (mm)	
		Ignitor	Sensor
A	130K	7-3/4 (197)	11 (279)
B	180K	5 (127)	5-1/2 (140)
C	240K	2-1/4 (57)	2-3/4 (70)

7- Replace access panel.

8- Restore electrical power and gas supply. Follow lighting instructions attached to unit and use inspection port in access panel to check flame.

D-Combustion Air Inducer (Gas Units)

A combustion air proving switch checks combustion air inducer operation before allowing power to the gas controller. Gas controller will not operate if inducer is obstructed.

Under normal operating conditions, the combustion air inducer wheel should be checked and cleaned prior to the heating season. However, it should be examined periodically during the heating season to establish an ideal cleaning schedule. With power supply disconnected, the condition of the inducer wheel can be determined by looking through the vent opening.

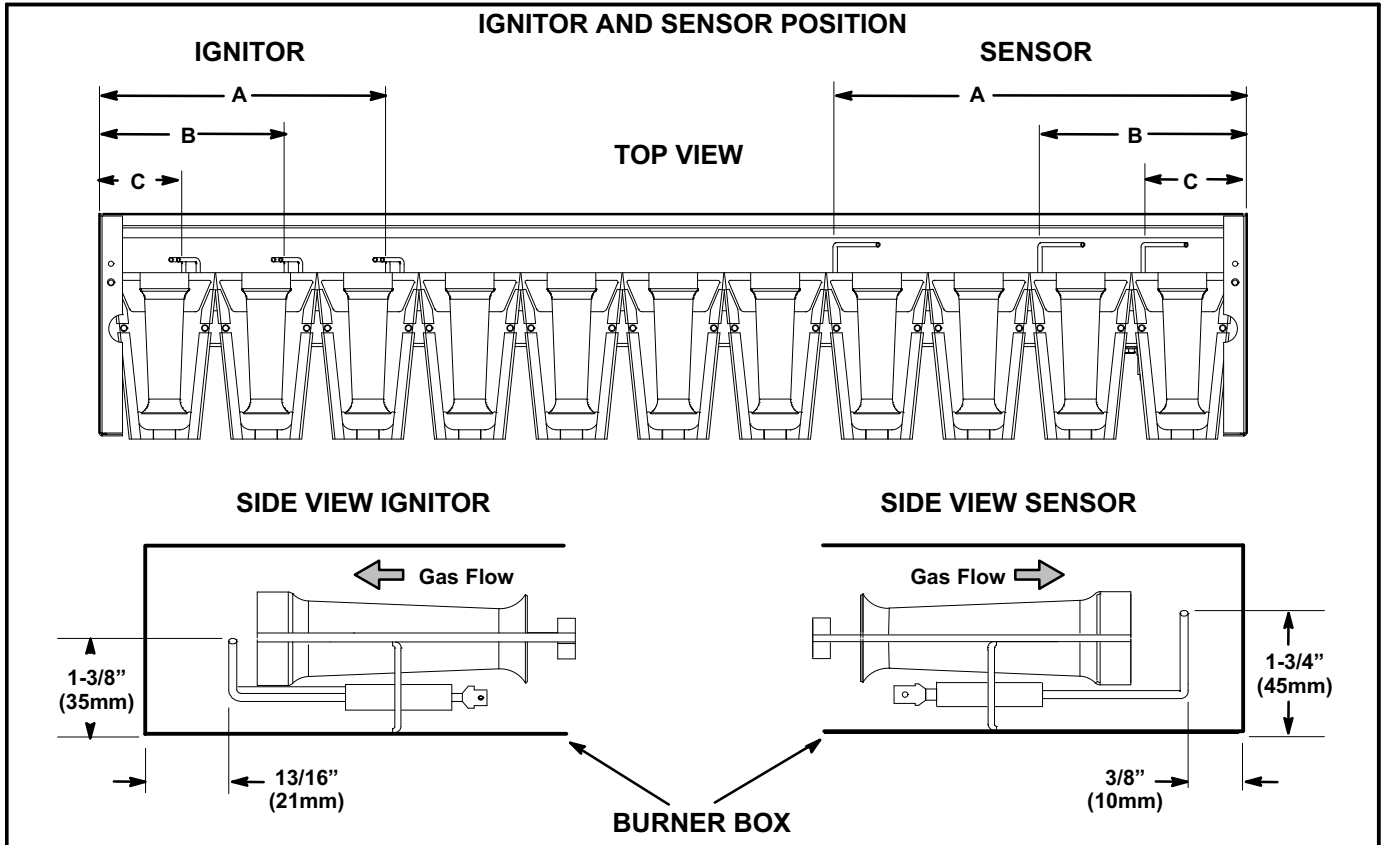

FIGURE 21

Clean combustion air inducer as follows:

- 1- Shut off power supply and gas to unit.
- 2- Disconnect pressure switch air tubing from combustion air inducer port.
- 3- Remove and retain screws securing combustion air inducer to flue box. Remove vent connector. See figure 22.

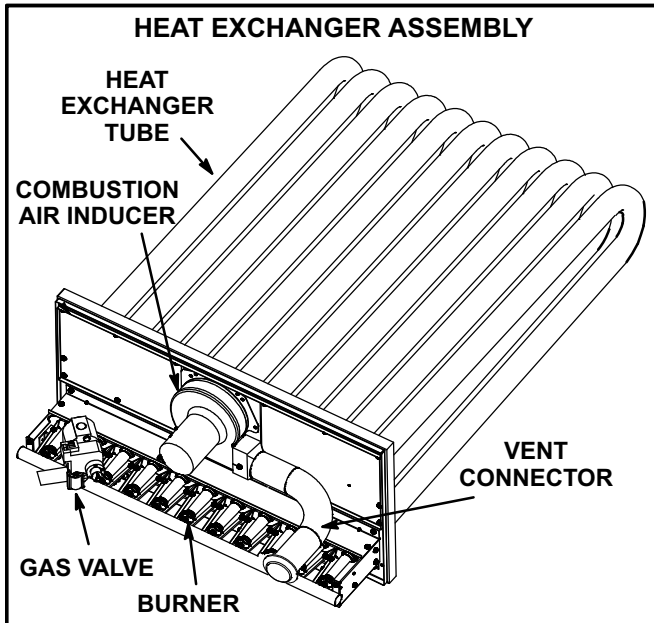

FIGURE 22

- 4- Clean inducer wheel blades with a small brush and wipe off any dust from housing. Clean accumulated dust from front of flue box cover.
- 5- Return combustion air inducer motor and vent connector to original location and secure with retained screws. It is recommended that the combustion air inducer gasket be replaced during reassembly.

- 6- Clean combustion air inlet louvers on heat access panel using a small brush.

F-Flue Passageway and Flue Box (Gas Units)

- 1- Remove combustion air inducer assembly as described in section D.
- 2- Remove flue box cover. Clean with a wire brush as required.
- 3- Clean tubes with a wire brush.
- 4- Reassemble the unit. The flue box cover gasket and combustion air inducer gasket should also be replaced during reassembly.

F-Evaporator Coil

Inspect and clean coil at beginning of each cooling season. Clean using mild detergent or commercial coil cleaner. Flush coil and condensate drain with water taking care not to get insulation, filters and return air ducts wet.

G-Condenser Coil

Clean condenser coil annually with detergent or commercial coil cleaner and inspect monthly during the cooling season.

Condenser coils are made of single, two, and three formed slabs. Dirt and debris may become trapped between the slabs. To clean between slabs, carefully separate coil slabs and wash them thoroughly. See figure 23. Flush coils with water following cleaning.

Note - Remove all screws and gaskets prior to cleaning procedure and replace upon completion.

H-Supply Air Blower Wheel

Annually inspect supply air blower wheel for accumulated dirt or dust. Turn off power before attempting to remove access panel or to clean blower wheel.

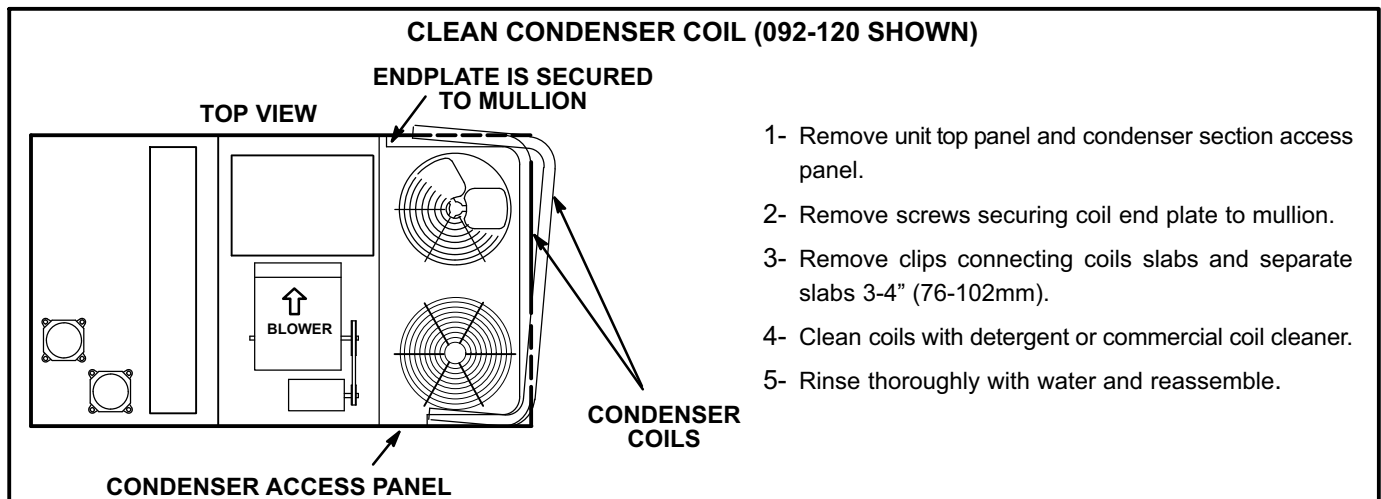

FIGURE 23

- 1- Remove unit top panel and condenser section access panel.
- 2- Remove screws securing coil end plate to mullion.
- 3- Remove clips connecting coils slabs and separate slabs 3-4" (76-102mm).
- 4- Clean coils with detergent or commercial coil cleaner.
- 5- Rinse thoroughly with water and reassemble.