

#### PRODUCT SPECIFICATIONS



072-090 Models



120-150 Models



180-240 Models

**EER up to 12.0**  
**6 to 20 Tons**  
**Cooling Capacity - 71,000 to 232,000 Btuh**

#### MODEL NUMBER IDENTIFICATION

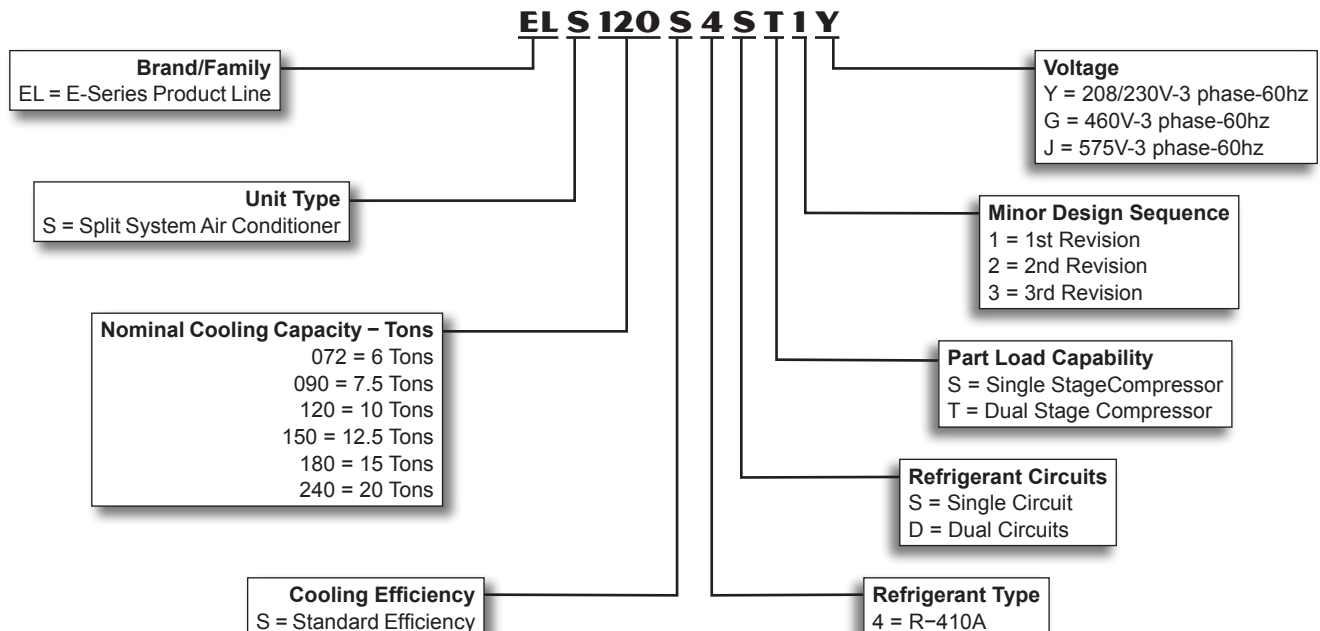

## FEATURES AND BENEFITS

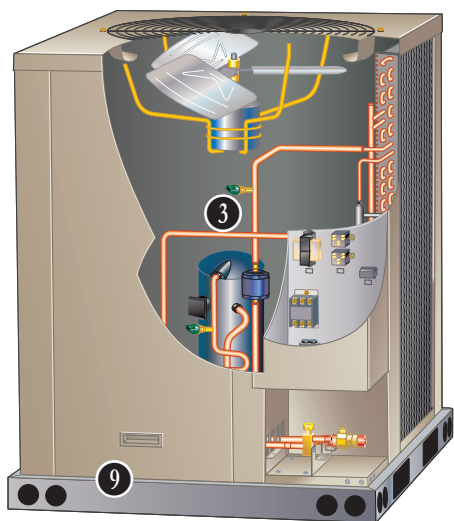

072-090 Models

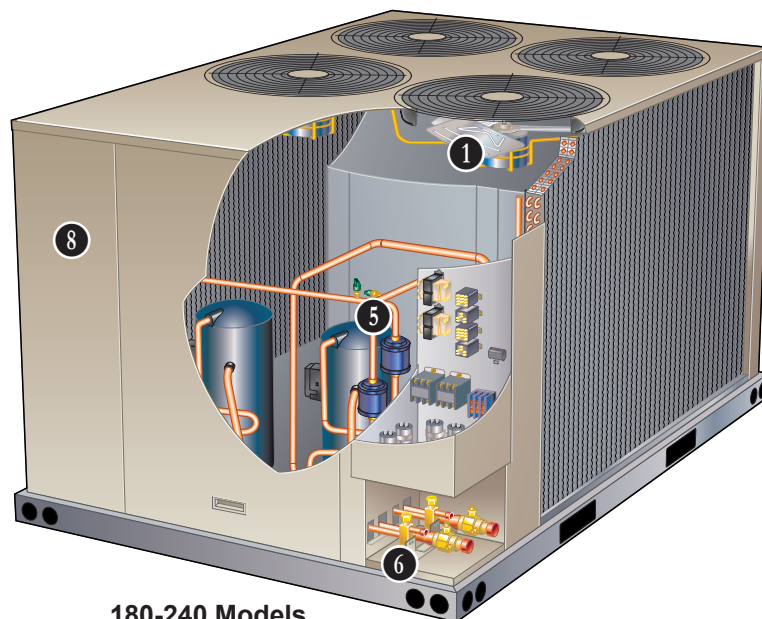

180-240 Models

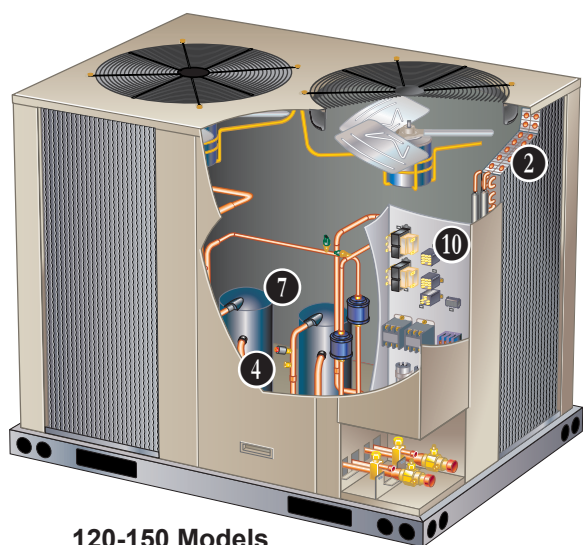

120-150 Models

### CONTENTS

AHRI System Matches .....	9
Dimensions .....	11
Features And Benefits .....	2
Model Number Identification .....	1
Options / Accessories .....	8
Ratings.....	14
Sound Data .....	9
Specifications.....	6
Unit Clearances .....	10
Weight Data .....	7

### EQUIPMENT WARRANTY

**Compressor** - Limited warranty for five years in non-residential applications.

**All other covered components** - One year in non-residential applications.

Refer to Allied Equipment Limited Warranty certificate for specific details.

### APPLICATIONS

Air conditioners are available in 6, 7.5, 10 ton (one compressor) and 10, 12.5, 15 and 20 ton (two compressors) nominal sizes.

Matching air handlers provide a wide range of cooling capacities and applications. See AHRI Ratings tables. See Air Handlers sections for air handler data.

Units shipped completely factory assembled, piped, and wired. Each unit is test operated at the factory insuring proper operation.

Installer must set air conditioner, connect refrigerant lines, add refrigerant charge and make electrical connections to complete job.

### APPROVALS

All units tested in an ETL certified environmental testing facility.

AHRI Certified to AHRI Standard 340/360-2015.

Sound tested in accordance with test conditions included in AHRI Standard 270 or 370.

Units and components within are bonded for grounding to meet safety standards for servicing required by UL, ULC, NEC and CEC.

All units are ETL listed.

All units meet two-stage cooling requirements of ASHRAE 90.1, IECC 2015, and California Code of Regulations, Title 24.

ISO 9001 Registered Manufacturing Quality System.

### REFRIGERATION SYSTEM

## FEATURES AND BENEFITS

### Refrigerant

Units operate with chlorine-free, ozone friendly, R-410A (field furnished).

### 1 Outdoor Coil Fan(s)

ELS072 and ELS090 units have one outdoor fan.  
ELS120 and ELS150 units have two outdoor fans.  
ELS180 and ELS240 units have four outdoor fans.

Direct drive fan(s) moves large volumes of air uniformly through entire condenser coil(s) for high refrigerant cooling capacity.

Upward discharge of air reduces operating sound levels and prevents damage to lawns, shrubs, and walkways.

Fan motors are totally enclosed, overload protected and equipped with a rain shield.

Fan service access is accomplished by removal of fan guard(s) or removal of access panel.

### 2 Copper Tube/Enhanced Fin Coil(s)

Units are equipped with a wrap-around “U” shaped coil (072-090-120 models) or two “L” shaped coils (150-180-240 models).

Coils are constructed of precisely spaced ripple-edge aluminum fins machine fitted to seamless copper tubes.

Lanced fins provide maximum exposure of fin surface to air stream resulting in excellent heat transfer.

Fins equipped with collars that grip tubing for maximum contact area.

Flared shoulder tubing connections and machine brazed silver soldering provide tight, leakproof joints.

Long life copper tubing is corrosion-resistant and easy to field service.

Thoroughly factory tested under high pressure to ensure leakproof construction.

Completely accessible for cleaning.

### 3 High Pressure Switch

Shuts off unit if abnormal operating conditions cause discharge pressure to rise above setting.

Protects the compressor from excessive condensing pressure.

Manual reset.

### 4 Loss of Charge Switch

Shuts off unit if liquid line pressure falls below setting.

Provides loss of charge and freeze-up protection.

Automatic reset.

### 5 Hi-Capacity Drier(s)

Drier traps moisture or dirt that could contaminate the refrigerant system.

### 6 Refrigerant Lines and Service Valves

Suction and liquid lines are located on corner of unit cabinet and are made with sweat connections. See dimension drawings.

Fully serviceable suction and liquid line service valves provide complete service access to refrigerant system.

Suction valve can be fully shut off, while liquid valve can be front seated to manage refrigerant charge while servicing system. Accessible outside of unit cabinet.

### 7 COMPRESSORS

ELS072, ELS090 and ELS120S4S models feature one dual-stage scroll compressor. ELS120S4D, ELS150S4D, ELS180S4D and ELS240S4D models have two single-stage scroll compressors.

Compressor features high efficiency with uniform suction flow, constant discharge flow and high volumetric efficiency and quiet operation.

Compressor consists of two involute spiral scrolls matched together to generate a series of crescent shaped gas pockets between them.

During compression, one scroll remains stationary while the other scroll orbits around it.

Gas is drawn into the outer pocket, the pocket is sealed as the scroll rotates.

As the spiral movement continues, gas pockets are pushed to the center of the scrolls. Volume between the pockets is simultaneously reduced.

When pocket reaches the center, gas is now high pressure and is forced out of a port located in the center of the fixed scrolls.

During compression, several pockets are compressed simultaneously resulting in a smooth continuous compression cycle.

Continuous flank contact, maintained by centrifugal force, minimizes gas leakage and maximizes efficiency.

Scroll compressor is tolerant to the effects of slugging and contaminants. If this occurs, scrolls separate, allowing liquid or contaminants to be worked toward the center and discharged.

Low gas pulses during compression reduces operational sound levels.

Compressor motor is internally protected from excessive current and temperature.

Compressor is installed in the unit on resilient rubber mounts for vibration free operation.

## FEATURES AND BENEFITS

### COMPRESSORS (continued)

#### ELS072, ELS090 and ELS120S4S Dual-Stage Models

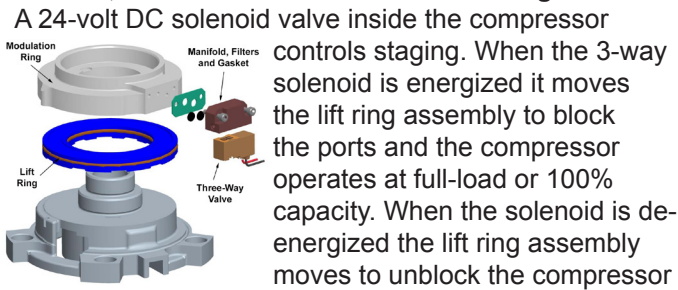

A 24-volt DC solenoid valve inside the compressor controls staging. When the 3-way solenoid is energized it moves the lift ring assembly to block the ports and the compressor operates at full-load or 100% capacity. When the solenoid is de-energized the lift ring assembly moves to unblock the compressor

ports and the compressor operates at part-load or approximately 67% of its full-load capacity.

The “loading” and “unloading” of the two stage scroll is done “on the fly” without shutting off the single-speed compressor motor between stages.

#### Crankcase Heater(s) (All Models)

Crankcase heater(s) prevents migration of liquid refrigerant into compressor(s) and ensures proper compressor lubrication.

### CABINET

- 8 Heavy-gauge, pre-painted steel cabinet provides superior rust and corrosion protection.  
Removable panels allow access for unit servicing.
- 9 Heavy duty steel base channels raise the unit off of mounting surface away from damaging moisture.  
Unit lifting holes and forklift slots furnished in base rails.  
See dimension drawings.
- 10 **Control Box**  
Control box located in separate compartment in unit cabinet.  
All controls are pre-wired at the factory.  
Control box is large enough for field installed DDC or other field supplied control modules.

### Options/Accessories

#### Factory Installed

##### Corrosion Protection

Polymeric epoxy coating that is deposited by electrical transport (electrophoresis), using a process known as electrocoat (e-coat). Available for enhanced coil corrosion protection. Factory installed on the condenser coil. Painted base pan is provided with this option.

#### Field Installed

##### Combination Coil/Hail Guards

Heavy gauge steel frame with expanded metal mesh to protect the outdoor coil from damage.

### CONTROLS

#### Options/Accessories

#### Field Installed

##### Low Ambient Control

Air conditioning units operate satisfactorily down to 45°F outdoor air temperature without any additional controls.

Low Ambient Control Kit can be field installed, allowing unit operation down to 0°F using pressure-regulated fan speed control.

##### Indoor Air Quality (CO<sub>2</sub>) Sensors

Monitors CO<sub>2</sub> levels, reports which adjusts economizer dampers as needed.

##### Thermostat

Thermostat is not furnished with unit and must be ordered extra.

##### Aftermarket Unit Controller Options

See Options/Accessories table for selection.

### ELECTRICAL

#### Field Installed

##### GFI Service Outlets (2)

115V ground fault circuit interrupter (GFCI) type, non-powered, field wired.

**THIS PAGE INTENTIONALLY LEFT BLANK**

## SPECIFICATIONS - 6 - 7.5 TON

General Data	Model No.	ELS072S4S	ELS090S4S
	<b>Nominal Size - Tons</b>	<b>6</b>	<b>7.5</b>
<b>Connections (sweat)</b>	Liquid line - in. (o.d)	(1) 3/8	(1) 5/8
	Suction line - in. (o.d)	(1) 1-1/8	(1) 1-1/8
<b>Refrigerant (R-410A)</b>	Factory Charge	R-410A holding charge (2 lbs. per stage)	
	<sup>1</sup> Field charge (25 ft. line set)	18 lbs. 0 oz. (includes holding charge)	20 lbs. 0 oz. (includes holding charge)
<b>Compressor</b>		(1) Dual-Stage Scroll	(1) Dual-Sstage Scroll
<b>Condenser Coil</b>	Net face area - sq. ft. Outer coil	29.3	29.3
	Inner coil	14.2	28.4
	Tube diameter - in. & no. of rows	3/8 - 1.5	3/8 - 2
	Fins per inch	20	20
<b>Condenser Fan(s)</b>	Diameter - in. & no. of blades	(1) 24 - 3	(1) 24 - 4
	Motor hp	(1) 1/3	(1) 1/2
	Total air volume - cfm	4700	5600
	Rpm	1075	1075
	Watts	400	580

## ELECTRICAL DATA

Line voltage data - 60 hz - 3 phase		208/230V	460V	575V	208/230V	460V	575V
<sup>2</sup> Maximum Overcurrent Protection (amps)		40	15	15	60	25	20
<sup>3</sup> Minimum circuit ampacity		24	12	9	37	17	13
<b>Compressor</b>	No. of Compressors	1	1	1	1	1	1
	Rated load amps	17.6	8.5	6.3	26.9	12	9
	Locked rotor amps	136	66	55	165	94	65
<b>Condenser Fan Motor (1 phase)</b>	No. of motors	1	1	1	1	1	1
	Full load amps	1.7	0.8	1	3	1.5	1.2
	Locked rotor amps	4.3	2.4	1.9	6	3	2.9

NOTE - Extremes of operating range are plus and minus 10% of line voltage.

<sup>1</sup> Field provided charge with 25 ft. line set. <sup>2</sup> HACR type circuit breaker or fuse.

<sup>3</sup> Refer to National or Canadian Electrical Code manual to determine wire, fuse and disconnect size requirements.

## SPECIFICATIONS - 10 TON

General Data	Model No.	ELS120S4S	ELS120S4D
	<b>Nominal Size - Tons</b>	<b>10</b>	<b>10</b>
<b>Connections (sweat)</b>	Liquid line - in. (o.d)	(1) 5/8	(2) 3/8
	Suction line - in. (o.d)	(1) 1-3/8	(2) 1-1/8
<b>Refrigerant (R-410A)</b>	Factory Charge	R-410A holding charge (2 lbs. per stage)	
	<sup>1</sup> Field charge (25 ft. line set)	Circuit 1 32 lbs. 0 oz. (includes holding charge)	Circuit 2 12 lbs. 0 oz. (includes holding charge)
		---	12 lbs. 0 oz. (includes holding charge)
<b>Compressor</b>		(1) Dual-Stage Scroll	(2) Single-Sstage Scroll
<b>Condenser Coil</b>	Net face area - sq. ft. Outer coil	29.3	29.3
	Inner coil	28.4	28.4
	Tube diameter - in. & no. of rows	3/8 - 2	3/8 - 2
	Fins per inch	20	20
<b>Condenser Fan(s)</b>	Diameter - in. & no. of blades	(2) 24 - 3	(2) 24 - 3
	Motor hp	(2) 1/3	(2) 1/3
	Total air volume - cfm	8300	8300
	Rpm	1075	1075
	Watts	830	830

## ELECTRICAL DATA

Line voltage data - 60 hz - 3 phase		208/230V	460V	575V	208/230V	460V	575V
<sup>2</sup> Maximum Overcurrent Protection (amps)		80	30	25	40	20	15
<sup>3</sup> Minimum circuit ampacity		47	21	16	30	16	13
<b>Compressor</b>	No. of Compressors	1	1	1	2	2	2
	Rated load amps (total)	34.6	14.8	11.1	12 (24)	6.3 (12.6)	4.9 (9.8)
	Locked rotor amps (total)	240	130	94	90 (180)	60 (120)	41 (82)
<b>Condenser Fan Motor (1 phase)</b>	No. of motors	2	2	2	2	2	2
	Full load amps (total)	1.7 (3.4)	0.8 (1.6)	1 (2)	1.7 (3.4)	0.8 (1.6)	1 (2)
	Locked rotor amps (total)	4.3 (8.6)	2.4 (4.8)	1.9 (3.8)	4.3 (8.6)	2.4 (4.8)	1.9 (3.8)

NOTE - Extremes of operating range are plus and minus 10% of line voltage.

<sup>1</sup> Field provided charge with 25 ft. line set. <sup>2</sup> HACR type circuit breaker or fuse.

<sup>3</sup> Refer to National or Canadian Electrical Code manual to determine wire, fuse and disconnect size requirements.

## SPECIFICATIONS - 12.5 - 20 TON

General Data		Model No.	ELS150S4D	ELS180S4D	ELS240S4D
Nominal Size - Tons			<b>12.5</b>	<b>15</b>	<b>20</b>
Connections (sweat)	Liquid line - in. (o.d)		(2) 5/8	(2) 5/8	(2) 5/8
	Suction line - in. (o.d)		(2) 1-1/8	(2) 1-1/8	(2) 1-3/8
Refrigerant (R-410A)	Factory Charge		R-410A holding charge (2 lbs. per stage)		
	<sup>1</sup> Field charge (25 ft. line set)	Circuit 1	15 lbs. 0 oz. (includes holding charge)	24 lbs. 0 oz. (includes holding charge)	22 lbs. 4 oz. (includes holding charge)
		Circuit 2	15 lbs. 0 oz. (includes holding charge)	24 lbs. 0 oz. (includes holding charge)	23 lbs. 3 oz. (includes holding charge)
Compressor			(2) Single-Stage Scroll	(2) Single-Stage Scroll	(2) Single-Stage Scroll
Condenser Coil	Net face area - sq. ft.		34.2	58.7	58.7
	Outer coil				
	Inner coil		33.3	57.7	57.7
	Tube diameter - in. & no. of rows		3/8 - 2	3/8 - 2	3/8 - 2
Fins per inch		20	20	20	
Condenser Fan(s)	Diameter - in. & no. of blades		(2) 24 - 4	(4) 24 - 3	(4) 24 - 3
	Motor hp		(2) 1/2	(4) 1/3	(4) 1/3
	Total air volume - cfm		10,300	16,600	16,600
	Rpm		1075	1075	1075
	Watts		1130	1660	1660

## ELECTRICAL DATA

Line voltage data - 60 hz - 3 phase		208/230V	460V	575V	208/230V	460V	575V	208/230V	460V	575V
<sup>2</sup> Maximum Overcurrent Protection (amps)		60	25	25	80	40	30	90	50	40
<sup>3</sup> Minimum circuit ampacity		50	21	20	63	31	25	70	36	30
Compressor	No. of Compressors	2	2	2	2	2	2	2	2	2
	Rated load amps (total)	19.6 (39.2)	8.2 (16.4)	6.6 (13.2)	25 (50)	12.2 (24.4)	9 (18)	28.2 (56.4)	14.7 (29.4)	11.3 (22.6)
	Locked rotor amps (total)	136 (272)	66 (132)	55 (110)	164 (328)	100 (200)	78 (156)	240 (480)	130 (260)	93.7 (187.4)
Condenser Fan Motor (1 phase)	No. of motors	2	2	2	4	4	4	4	4	4
	Full load amps (total)	3 (6)	1.5 (3)	1.2 (2.4)	1.7 (6.8)	0.8 (3.2)	1 (4)	1.7 (6.8)	0.8 (3.2)	1 (4)
	Locked rotor amps (total)	6 (12)	3 (6)	2.9 (5.8)	4.3 (17.2)	2.4 (9.6)	1.9 (7.6)	4.3 (17.2)	2.4 (9.6)	1.9 (7.6)

NOTE - Extremes of operating range are plus and minus 10% of line voltage.

<sup>1</sup> Field provided charge with 25 ft. line set. <sup>2</sup> HACR type circuit breaker or fuse.

<sup>3</sup> Refer to National or Canadian Electrical Code manual to determine wire, fuse and disconnect size requirements.

## WEIGHT DATA

Model No.	Net		Shipping	
	lbs.	kg	lbs.	kg
072S4S	318	144	338	153
090S4S	345	157	365	166
120S4S	452	205	477	216
120S4D	480	218	505	229
150S4D	535	243	560	254
180S4D	775	352	800	363
240S4D	832	377	857	389

## OPTIONS / ACCESSORIES

### COMBINED COIL/HAIL GUARDS

T2GARD20L-1	40	18	45	20
T2GARD20M-1	45	20	50	23
T2GARD21M-1	45	20	50	23
T2GARD20N-1	90	41	100	45

## OPTIONS / ACCESSORIES

Item	Catalog No.	ELS 072 S4S	ELS 090 S4S	ELS 120 S4S	ELS 120 S4D	ELS 150 S4D	ELS 180 S4D	ELS 240 S4D
<b>CABINET</b>								
Combined Coil/Hail Guards	T2GARD51L-1	13T29	X	X				
	T2GARD51M11	13T30			X	X		
	T2GARD51M21	13T32				X		
	T2GARD51N-1	13T37					X	X
Corrosion Protection	Factory	O	O	O	O	O	O	O

## CONTROLS

BACnet® Module	A0CTRL31LS1	17A08	X	X	X	X	X	X
BACnet® Sensor with Display	K0SNSR01FF1	97W23	X	X	X	X	X	X
BACnet® Sensor without Display	K0SNSR00FF1	97W24	X	X	X	X	X	X
Low Ambient Control (0°F)	A2CWKT01LM1-	16F18	X	X				
	A2CWKT04M-1-	16F26			X			
	A2CWKT02M-1-	16F24				X	X	
	A2CWKT03N-1-	16F25					X	X

## ELECTRICAL

GFI Service Outlets	15 amp non-powered, field-wired (208/230V, 460V only) LTAGFIK10/15/15	74M70	X	X	X	X	X	X
		67E01	X	X	X	X	X	X
	20 amp non-powered, field-wired (575V only) C1GFIC120FF1							

## INDOOR AIR QUALITY

Sensor - Wall-mount, off-white plastic cover with LCD display	C0SNSR50AE1L	77N39	X	X	X	X	X	X
Sensor - Wall-mount, off-white plastic cover, no display	C0SNSR52AE1L	87N53	X	X	X	X	X	X
Sensor - Black plastic case with LCD display, rated for plenum mounting	C0SNSR51AE1L	87N52	X	X	X	X	X	X
Sensor - Wall-mount, black plastic case, no display, rated for plenum mounting	C0SNSR53AE1L	87N54	X	X	X	X	X	X
CO <sub>2</sub> Sensor Duct Mounting Kit	C0MISC19AE1-	85L43	X	X	X	X	X	X
Aspiration Box - for duct mounting non-plenum rated CO <sub>2</sub> sensor (77N39)	C0MISC16AE1-	90N43	X	X	X	X	X	X

NOTE - The catalog and model numbers that appear here are for ordering field installed accessories only.

O - Factory Installed with extended lead time.

X - Field Installed



## AHRI SYSTEM MATCHES

Model	Cooling Btuh	EER	IEER	Air Handler	Expansion Device	AHRI Reference
ELS072S4S	71,000	12.0	16.0	ELA072S4S	Factory TXV	201753420
ELS090S4S	89,000	11.2	14.4	ELA090S4D	Factory TXV	201753421
ELS120S4S	115,000	11.2	14.4	ELA120S4D	Factory TXV	201753423
ELS120S4D	115,000	11.2	12.9	ELA120S4D	Factory TXV	201753422
ELS150S4D	136,000	11.0	12.4	ELA150S4D	Factory TXV	201753424
ELS180S4D	178,000	11.0	12.4	ELA180S4D	Factory TXV	201753975
ELS240S4D	232,000	11.0	12.4	ELA240S4D	Factory TXV	201753426

NOTES - Units with capacity of 65,000 Btuh or greater are AHRI Certified to AHRI Standard 340/360: 95°F outdoor air temperature, 80°F db/67°F wb entering evaporator air (minimum external duct static pressure) with 25 ft. of connecting refrigerant lines.

## SOUND DATA

<sup>1</sup> Unit Model No.	Octave Band Linear Sound Power Levels dB, re 10 <sup>-12</sup> Watts Center Frequency - HZ							<sup>1</sup> Sound Rating Number (dB)
	125	250	500	1000	2000	4000	8000	
ELS072S4S	65	68	73	76	72	68	63	81
ELS090S4S	64	69	73	77	74	70	63	81
ELS120S4S	70	77	82	81	77	75	71	86
ELS120S4D	71	77	80	80	77	72	67	85
ELS150S4D	68	77	80	82	78	73	65	86
ELS180S4D	73	80	83	83	79	74	66	88
ELS240S4D	73	80	85	84	80	78	74	89

NOTE - the octave sound power data does not include tonal correction.

<sup>1</sup> Tested according to AHRI Standard 270 test conditions.

## UNIT CLEARANCES - INCHES (MM)

### ELS072 and ELS090

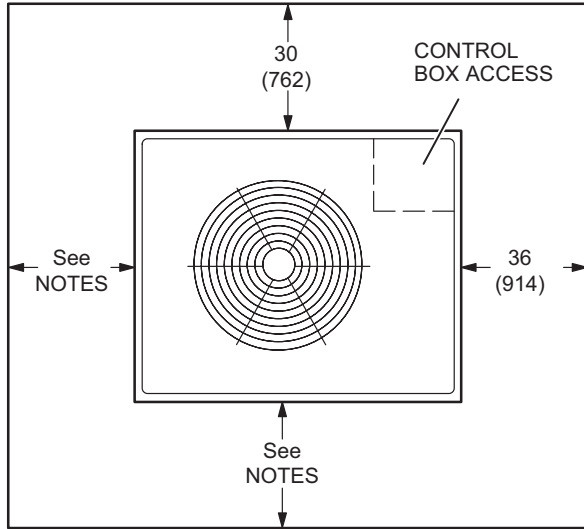

**NOTES:**

Clearance to one of the remaining two sides may be 12 in. (305 mm) and the final side may be 6 in. (152 mm).

A clearance of 24 in. (610 mm) must be maintained between two units.

48 in. (1219 mm) clearance required on top of unit.

### ELS120 and ELS150

**NOTES:**

Clearance to one of the remaining two sides may be 12 in. (305 mm) and the final side may be 6 in. (152 mm).

A clearance of 24 in. (610 mm) must be maintained between two units.

48 in. (1219 mm) clearance required on top of unit.

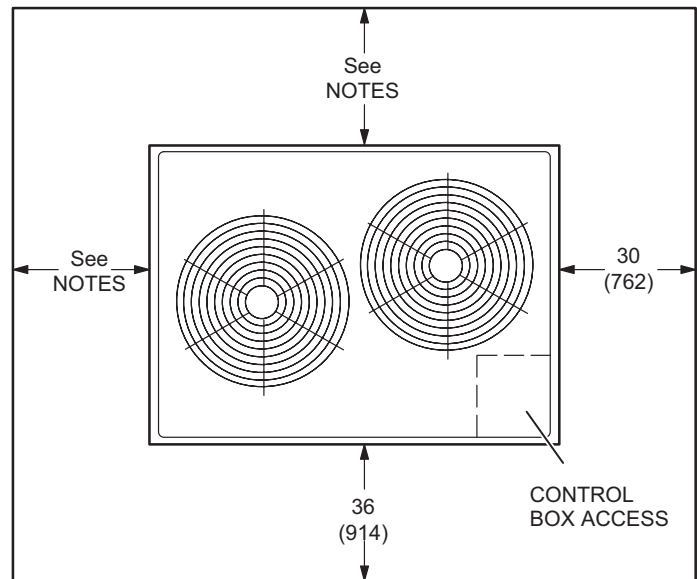

### ELS180 and ELS240

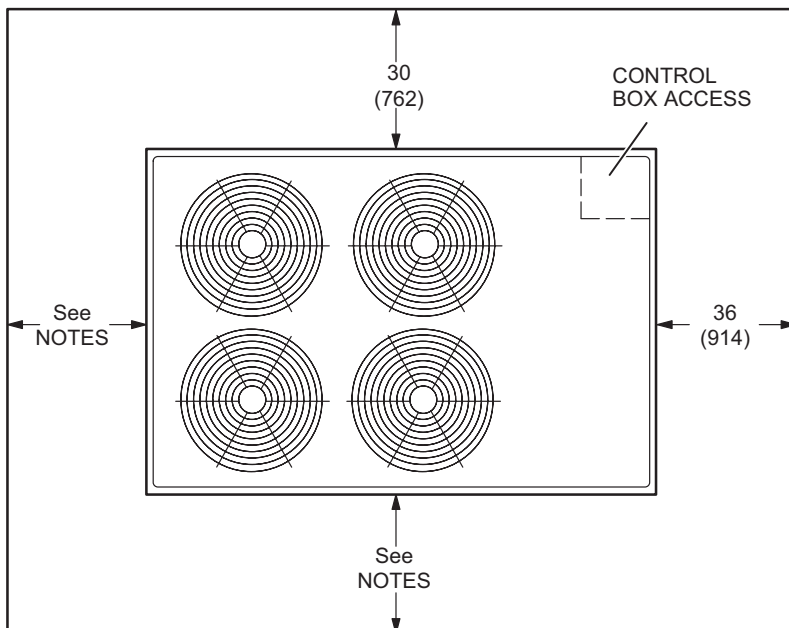

**NOTES:**

Clearance to one of the remaining two sides may be 12 in. (305 mm) and the final side may be 6 in. (152 mm).

A clearance of 24 in. (610 mm) must be maintained between two units.

48 in. (1219 mm) clearance required on top of unit.

## DIMENSIONS - INCHES (MM) - ELS072 AND ELS090

Model No.	CORNER WEIGHTS								CENTER OF GRAVITY			
	AA		BB		CC		DD		EE		FF	
	lbs.	kg	lbs.	kg	lbs.	kg	lbs.	kg	in.	mm	in.	mm
ELS072S4S	66	30	73	33	97	44	82	37	23-1/4	591	19-1/4	489
ELS090S4S	75	34	89	40	112	51	88	40	25	635	20-1/4	514

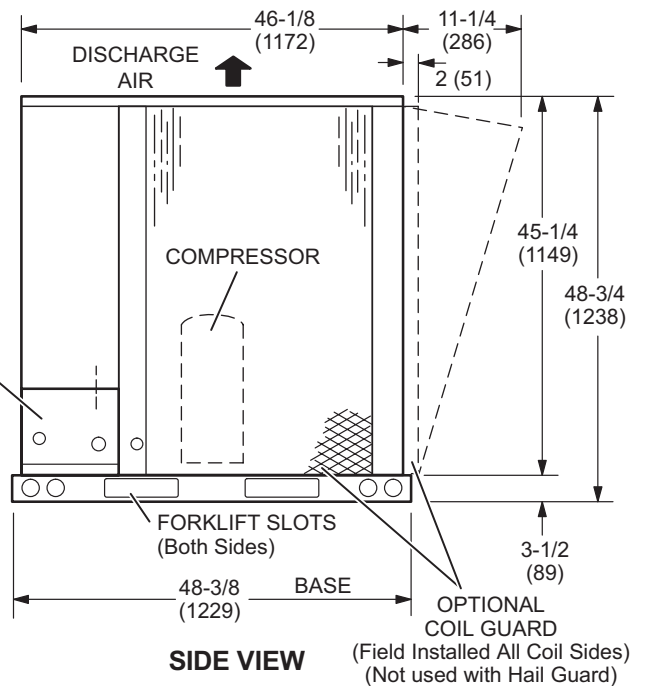
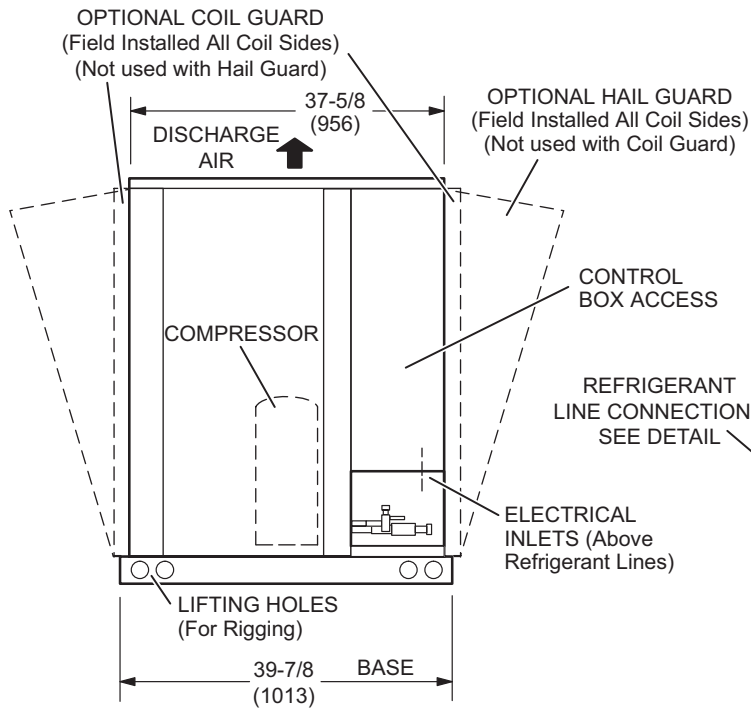
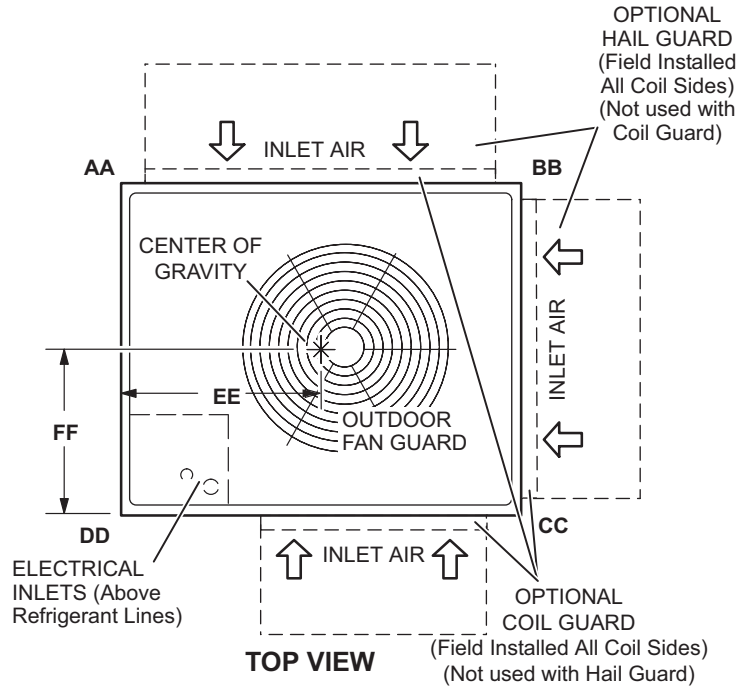
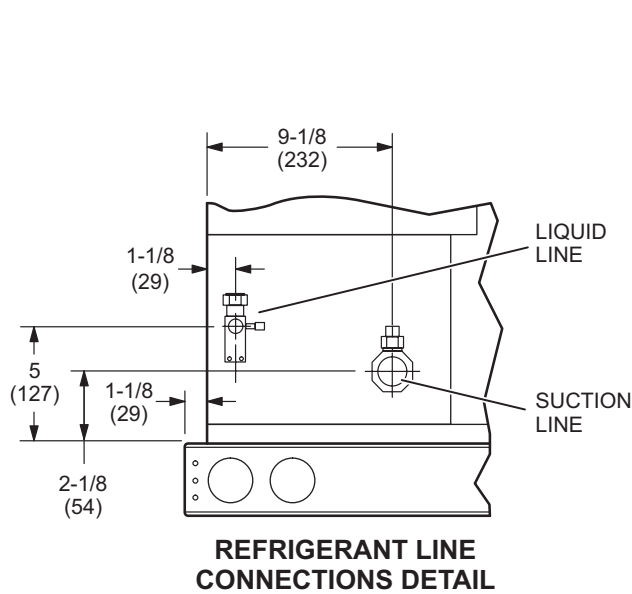

# DIMENSIONS - INCHES (MM) - ELS120 AND ELS150

Model No.	CORNER WEIGHTS								CENTER OF GRAVITY			
	AA		BB		CC		DD		EE		FF	
	lbs.	kg	lbs.	kg	lbs.	kg	lbs.	kg	in.	mm	in.	mm
ELS120S4S	130	59	124	56	107	49	111	50	20-1/2	521	33-1/2	851
ELS120S4D	122	55	119	54	127	58	131	59	21	533	28-1/2	724
ELS150S4D	144	66	132	60	133	60	145	66	19	483	30	762

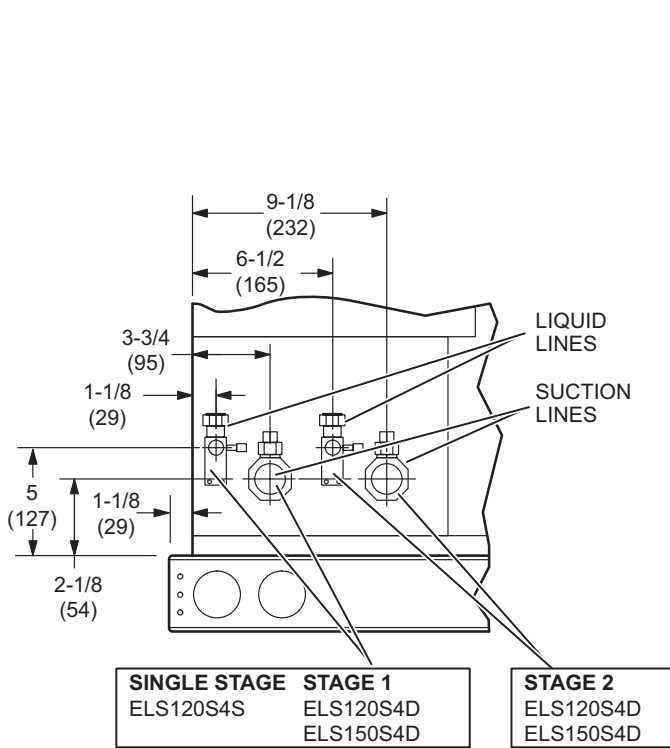

**REFRIGERANT LINE CONNECTIONS DETAIL**

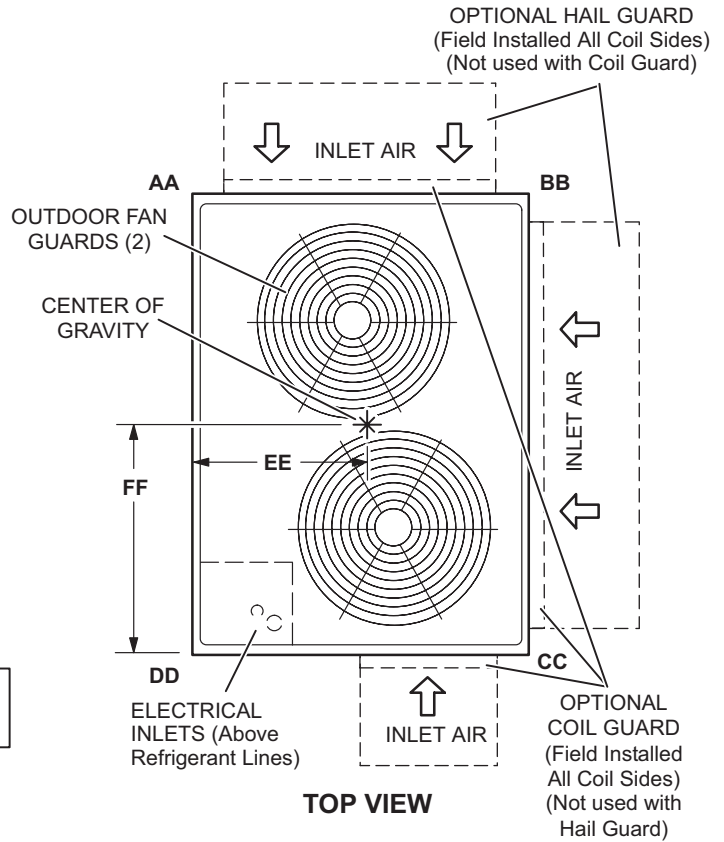

**TOP VIEW**

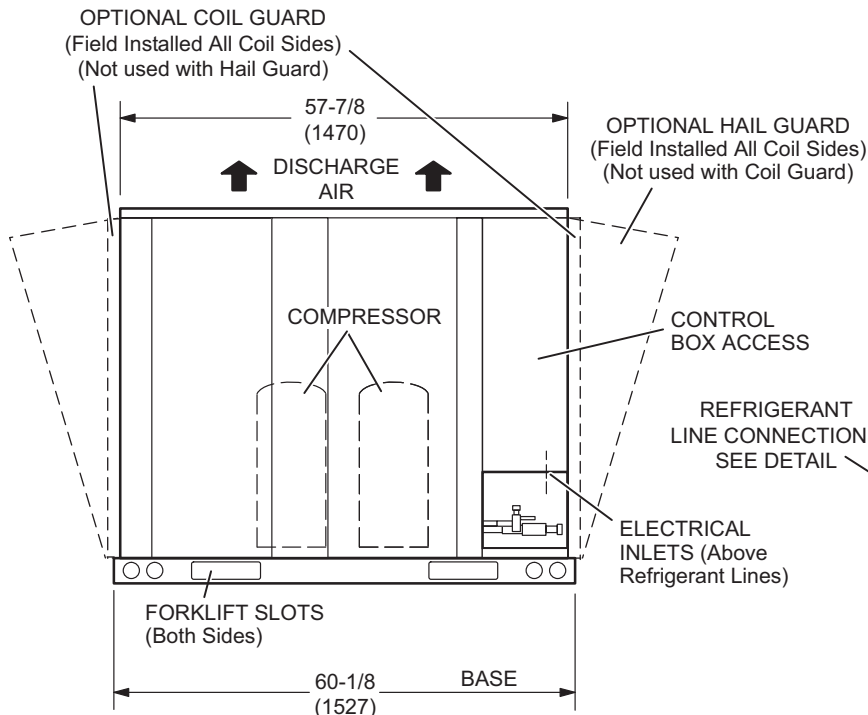

**FRONT VIEW**

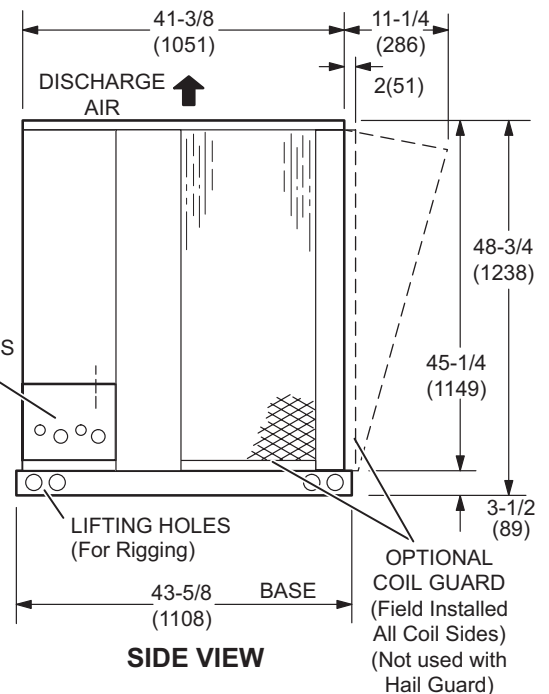

**SIDE VIEW**

# DIMENSIONS - INCHES (MM) - ELS180 AND ELS240

Model No.	CORNER WEIGHTS								CENTER OF GRAVITY			
	AA		BB		CC		DD		EE		FF	
	lbs.	kg	lbs.	kg	lbs.	kg	lbs.	kg	in.	mm	in.	mm
ELS180S4D	181	82	177	81	215	98	221	100	29	737	38	965
ELS240S4D	192	87	189	86	232	105	238	108	29	737	37-1/2	953

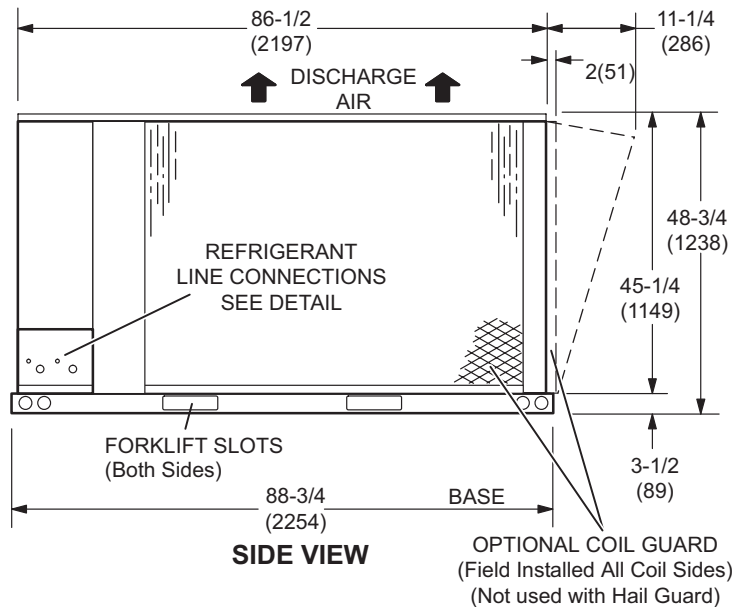
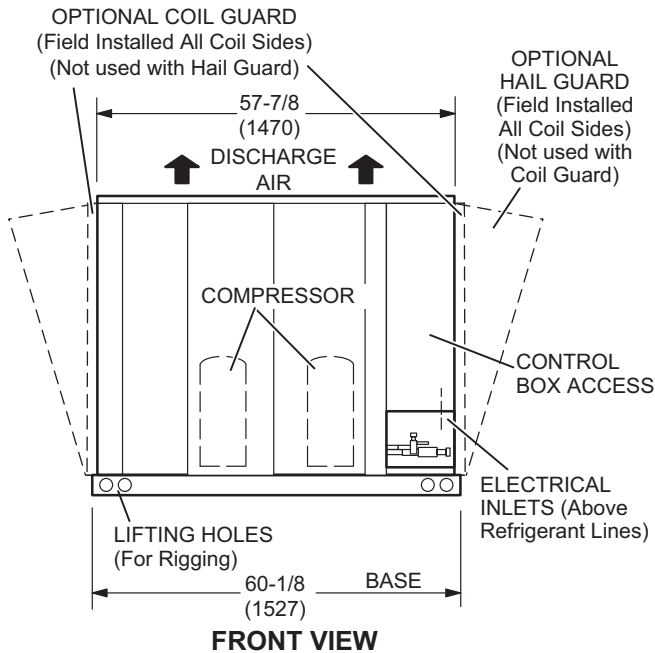
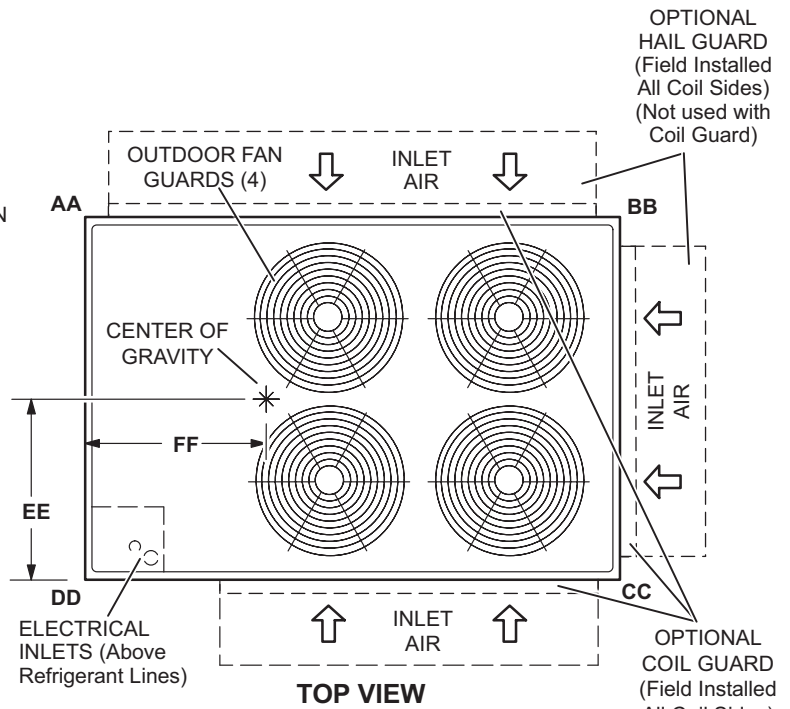
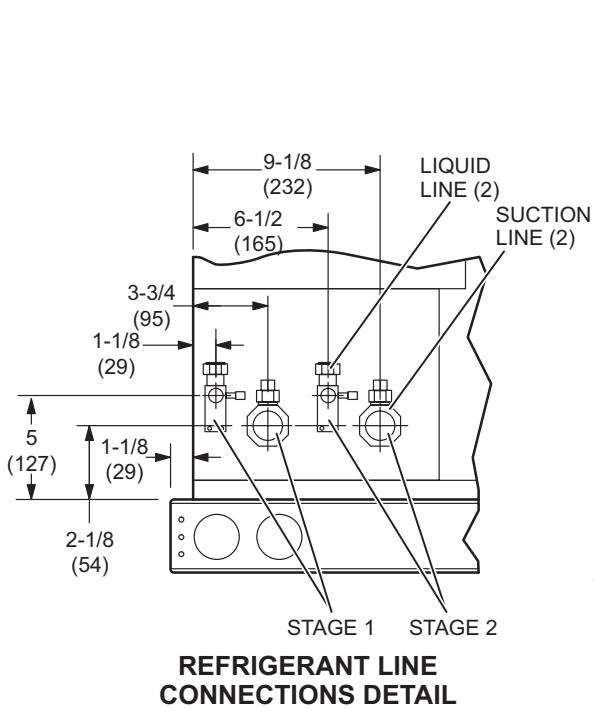



# RATINGS

NOTE - For Temperatures and Capacities not shown in tables, see bulletin - Cooling Unit Rating Table Correction Factor Data in Miscellaneous Engineering Data section.

## ELS120S4S + ELA120S4D - PART LOAD

Entering Wet Bulb Temperature	Total Air Volume	Outdoor Air Temperature Entering Outdoor Coil																			
		65°F					75°F					85°F					95°F				
		Total Cool Cap.	Comp. Motor Input	Sensible To Total Ratio (S/T)			Total Cool Cap.	Comp. Motor Input	Sensible To Total Ratio (S/T)			Total Cool Cap.	Comp. Motor Input	Sensible To Total Ratio (S/T)			Total Cool Cap.	Comp. Motor Input	Sensible To Total Ratio (S/T)		
				Dry Bulb					Dry Bulb					Dry Bulb					Dry Bulb		
cfm	kBtuh	kW	75°F	80°F	85°F	kBtuh	kW	75°F	80°F	85°F	kBtuh	kW	75°F	80°F	85°F	kBtuh	kW	75°F	80°F	85°F	
63°F	2240	88.8	3.53	0.72	0.84	0.97	84.9	4.16	0.73	0.86	0.99	80.1	4.87	0.75	0.89	1	74.3	5.67	0.78	0.93	1
	2800	93.5	3.49	0.77	0.91	1	89.7	4.12	0.78	0.93	1	84.5	4.83	0.8	0.96	1	78.5	5.63	0.83	0.99	1
	3360	97	3.48	0.81	0.98	1	93.2	4.1	0.83	0.99	1	88.6	4.79	0.85	1	1	83.3	5.58	0.88	1	1
67°F	2240	94.5	3.49	0.57	0.69	0.81	90.5	4.11	0.58	0.7	0.83	85.7	4.81	0.59	0.72	0.85	80	5.61	0.6	0.75	0.88
	2800	99.1	3.46	0.6	0.74	0.88	95.5	4.08	0.61	0.76	0.9	90.5	4.79	0.61	0.78	0.92	84	5.58	0.64	0.8	0.96
	3360	102.5	3.44	0.63	0.79	0.95	99.1	4.06	0.64	0.81	0.96	93.7	4.76	0.65	0.82	0.99	87.2	5.54	0.67	0.85	1
71°F	2240	100.2	3.46	0.44	0.56	0.67	96.4	4.07	0.43	0.55	0.67	91.9	4.77	0.44	0.58	0.69	85.7	5.56	0.45	0.58	0.71
	2800	104.8	3.43	0.45	0.59	0.71	101.2	4.04	0.45	0.59	0.73	96.1	4.74	0.46	0.6	0.75	90	5.53	0.46	0.62	0.77
	3360	107.9	3.42	0.46	0.62	0.77	104.6	4.02	0.46	0.63	0.78	99.4	4.72	0.47	0.64	0.8	93.2	5.51	0.48	0.66	0.83

## ELS120S4S + ELA120S4D - FULL LOAD

Entering Wet Bulb Temperature	Total Air Volume	Outdoor Air Temperature Entering Outdoor Coil																			
		85°F					95°F					105°F					115°F				
		Total Cool Cap.	Comp. Motor Input	Sensible To Total Ratio (S/T)			Total Cool Cap.	Comp. Motor Input	Sensible To Total Ratio (S/T)			Total Cool Cap.	Comp. Motor Input	Sensible To Total Ratio (S/T)			Total Cool Cap.	Comp. Motor Input	Sensible To Total Ratio (S/T)		
				Dry Bulb					Dry Bulb					Dry Bulb					Dry Bulb		
cfm	kBtuh	kW	75°F	80°F	85°F	kBtuh	kW	75°F	80°F	85°F	kBtuh	kW	75°F	80°F	85°F	kBtuh	kW	75°F	80°F	85°F	
63°F	3200	112.6	7.39	0.73	0.87	0.99	107.1	8.19	0.74	0.88	1	101.5	9.15	0.76	0.91	1	94.6	10.21	0.78	0.94	1
	4000	118.1	7.46	0.78	0.93	1	112.4	8.27	0.8	0.96	1	106.1	9.22	0.82	0.98	1	99.6	10.31	0.85	1	1
	4800	122.5	7.53	0.83	0.99	1	116.9	8.35	0.85	1	1	111.1	9.3	0.88	1	1	104.6	10.4	0.91	1	1
67°F	3200	119.5	7.48	0.58	0.7	0.83	114.2	8.31	0.59	0.72	0.85	107.9	9.25	0.59	0.73	0.87	100.9	10.34	0.61	0.76	0.9
	4000	125.5	7.57	0.61	0.76	0.9	119.4	8.39	0.62	0.77	0.92	112.8	9.33	0.63	0.79	0.95	105.2	10.39	0.65	0.82	0.98
	4800	129.6	7.64	0.64	0.81	0.96	123.2	8.46	0.65	0.83	0.98	116.3	9.39	0.67	0.85	1	108.8	10.46	0.68	0.88	1
71°F	3200	127	7.59	0.44	0.56	0.68	121.3	8.42	0.45	0.57	0.69	114.9	9.37	0.45	0.58	0.71	107.7	10.43	0.45	0.6	0.74
	4000	133	7.69	0.45	0.59	0.73	126.9	8.52	0.46	0.6	0.75	119.8	9.45	0.46	0.62	0.77	112	10.52	0.47	0.64	0.8
	4800	137.1	7.75	0.47	0.63	0.79	130.8	8.57	0.47	0.64	0.8	123.6	9.51	0.48	0.66	0.83	115.3	10.58	0.49	0.68	0.86













Visit us at [www.allied-commercial.com](http://www.allied-commercial.com)

For the latest technical information, visit us at [www.allied-commercial.com](http://www.allied-commercial.com)

Contact us at 1-800-738-4000

NOTE - Due to Allied Commercial ongoing commitment to quality, Specifications, Ratings and Dimensions subject to change without notice and without incurring liability. Improper installation, adjustment, alteration, service or maintenance can cause property damage or personal injury. Installation and service must be performed by a qualified installer and servicing agency.

©2018 Allied Air Enterprises LLC, a Lennox International Inc. Company